



**International Symposium Marco Polo and other Small Body  
Sample Return Missions**

**SAMPLING RELATED ISSUES FOR  
MISSIONS TO ASTEROID**

**P. Magnani   M. Izzo   C. Mondellini   E. Re**

**18-19-20 May 2009 Paris**

## Table of contents:

- Brief overview on requirements and environment
- Example of sampling method: ‘instant type’ approach
- Example of sampling method: ‘touch and go pad’ approach
- Example of sampling method: “landing short stay” approach
- Conclusions

The Sampling requirements related to a mission to an asteroid have been derived based on three input documents of Marco-Polo Mission, available at the beginning of the activity:

Mission Requirement Document (SCI-PA/2008.001/Marco-Polo);  
Part of chapter 3.2 and 3.6 of the Science Requirements Document (MP-RSSD-RS-001);  
Mission Environment Document (SCI-PA/2008.014/Marco-Polo).

In the following slides the main sampling requirements and environmental characteristics are briefly summarized

## *R-SS.MEC-1 Sampling mechanism*

*The sampling mechanism shall be able to collect a minimum of 30 g of NEO material with a goal of 100 g*

## *R-SS.MEC-2 Sampling mechanism*

*The sampling mechanism shall be able to collect cm-sized pebbles (up to 3 cm), plus a large amount ( $10^4$ ) of small particles (100s of  $\mu\text{m}$ -sized to mms-sized)*

## *R-SS.MEC-3 Sampling mechanism*

*The surface properties which shall be assumed for the design of the sampling mechanism include the following:*

- Grain Size: Sub- $\mu\text{m}$   $\rightarrow$  mm  $\rightarrow$  up to 3 cm*
- Cohesion: 0.1-1 kPa*
- Compressive strength: up to 100 kPa*
- Bulk density: <1.1 – 1.8 (max)*

## *R-SS.MEC-4 Sampling verification*

*The sampling mechanism (or any other part of the spacecraft) shall be equipped with autonomous means of verifying suitable sampling*

## *G-OP.POX-1 Multiple sampling*

*It should be possible to collect one sample at three different locations and keep them separated*

## *R-SY.LAN-1 Landing/touchdown conditions*

*The landing/touchdown/sampling module shall approach the surface with a maximum horizontal velocity of 5 cm/s (TBC)*

## *R-SY.LAN-3 Landing conditions*

*The descent/landing module shall have a maximum attitude of +/- 10 ° with respect to the local surface at landing/touchdown*

## Temperature aspects – Technology impacts

Large variation in temperature ( $< -150^{\circ}\text{C}$  and  $> +210^{\circ}\text{C}$ ) appears on four asteroid candidates (1999 JU3, 2001 SK 162, 1989 UQ, 2001 SG 286) depending on asteroid, distance from sun and hour of local day.

From a technology point of view a distinction has to be done between *low temperatures* (from e.g. ambient to  $< -150^{\circ}\text{C}$ ) and *high temperatures* (e.g.  $> +210^{\circ}\text{C}$ ).

Concerning the *low side temperatures* important experience can be derived from the different developments so far performed like: Rosetta Sample Drill and Distribution system (e.g. operation down to  $-150^{\circ}\text{C}$ ) and Exomars (e.g. operation down to  $-80^{\circ}\text{C}$ ).

We consider moderately critical the low temperature scenario.

## Temperature aspects – Technology impacts

Concerning the *high side temperatures*, up to the +120/+150°C limits the mechanics and electromechanics can still be developed even if with some difficulties (e.g. some experience in robotic field with operative temperature of + 80°C and a storage of +150°C).

Above this (e.g. moving toward an environment of >200°C) special attention has to be placed at least in the following areas:

- wires isolation/impregnation in electrical actuators;
- insulation of movable cables (e.g. passing along movable articulations);
- general use of non metallic materials;
- lubrication.

Electronics (especially with active components) cannot be exposed to such temperatures and no active components are to be located in exposed parts.

## Soil properties and morphology – Technology impacts

The information concerning asteroid surface reported in applicable documentation are primarily based on Moon surface features and on some previous observation on other small bodies.

The specific characteristics of the target NEO are however unknown and at least two effects could be present:

sorting effect due to seismic shaking following impacts would reduce the presence of 'small particles' in favour of the 'large particles' at the surface  
more angular shape of particles (favouring more irregular shaping)

Local morphology is basically unknown. Large variations on appearances like presence of meter scale boulders/agglomerates, local meter size valleys, sub meters size obstacles/rocks could be possible as close up images from EROS evidenced.

The possible presence of decimetres size agglomerates/rocks local to the sampling area cannot be excluded.



## Example of sampling methods

In the present Marco Polo studies several sampling methods have been considered and are under evaluation.

In the next slides three of such methods are briefly illustrated:

- ‘Instant’ type approach;
- ‘touch and go pad’ approach;
- ‘landing short stay’ approach

## Example of sampling method: 'instant type' approach

The 'instant' type sampler after described is basically compatible with all missions type (landing short stay, touch and go, hover and go).

*A sampling tube (instant shallow pusher)* is in charge of the real sample material collection, and (first) containment and is the part being repositioned back (filled with collected material) for return to earth. In this sampling approach the sampling tube is very simple, totally passive and does not contain any moving parts.

The tool is thin wall, present a grasping interface and is equipped with elastic (metallic) occluders.

The sampling tube can be attached to a reference container (e.g. re entry, depot, .....).

## “Instant” shallow pusher – schematics

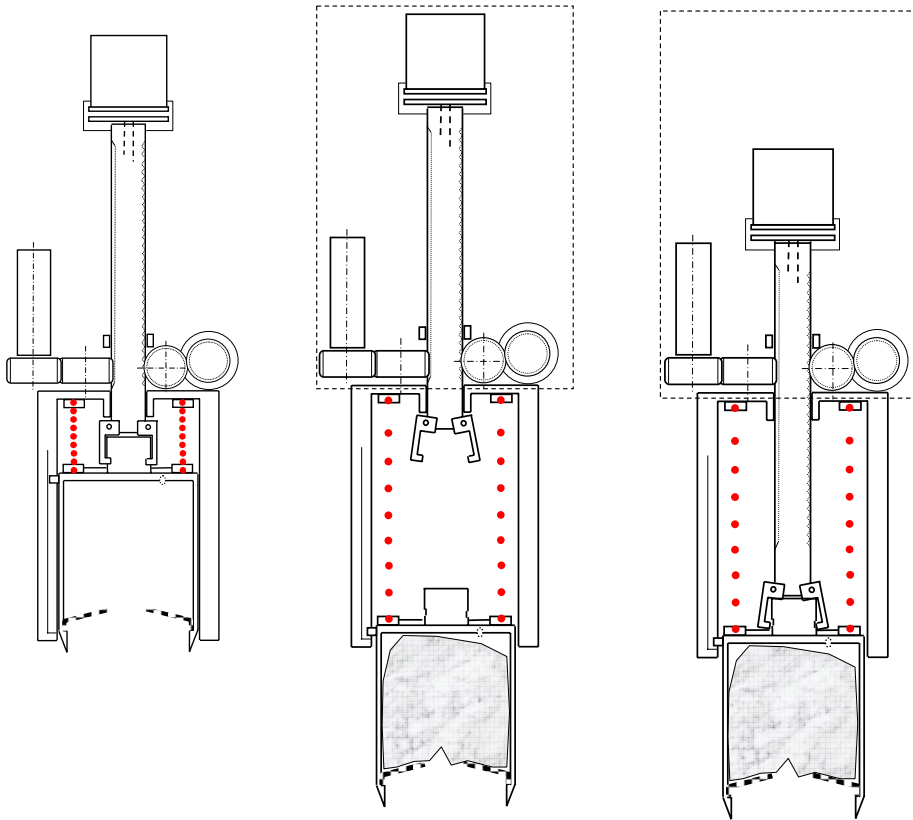

*Schematics of sampling tube with occluders*

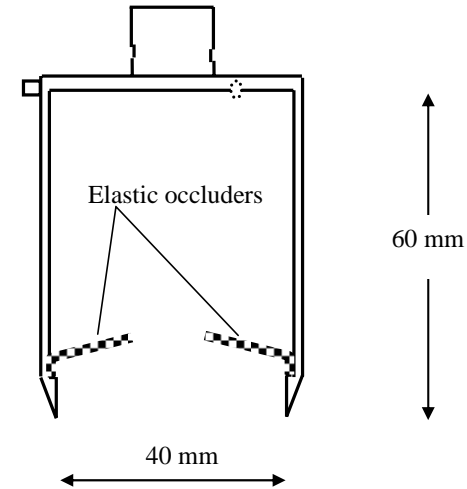

*Schematics of sampling tube  
with occluders*

- Expected sampling performance
- total sampling time: ~ 0.1 s
  - required vertical thrust: < some Newtons / few tens of Newtons (for the limited time)
  - amount of collected material: ~ 50 gr

## Example of sampling method: 'touch and go pad' approach

The 'touch and go pad' type sampler here-after described is suitable for a touch and go mission.

Three sampling tools are deployed to the soil by means of three different recovery systems installed on the bottom of the S/C.

Each sampling tool is activated once to collect the sample.

After collecting three samples the three tools are retrieved and available to the canister for the transfer into the re-entry capsule.

# Sampling technology – example of sampling methods 'touch and go pad'

The pad after the contact with the soil has a relative motion with respect to the other parts of the tool.

The shutters are triggered by a dedicated spring actuator.

The tool has a square area because of the simplicity of the shutter system with respect to a circular area.

No rotational action is needed but only pushing.

The concept to adopt for the shutter is the “awning” concept as shown in this sequence

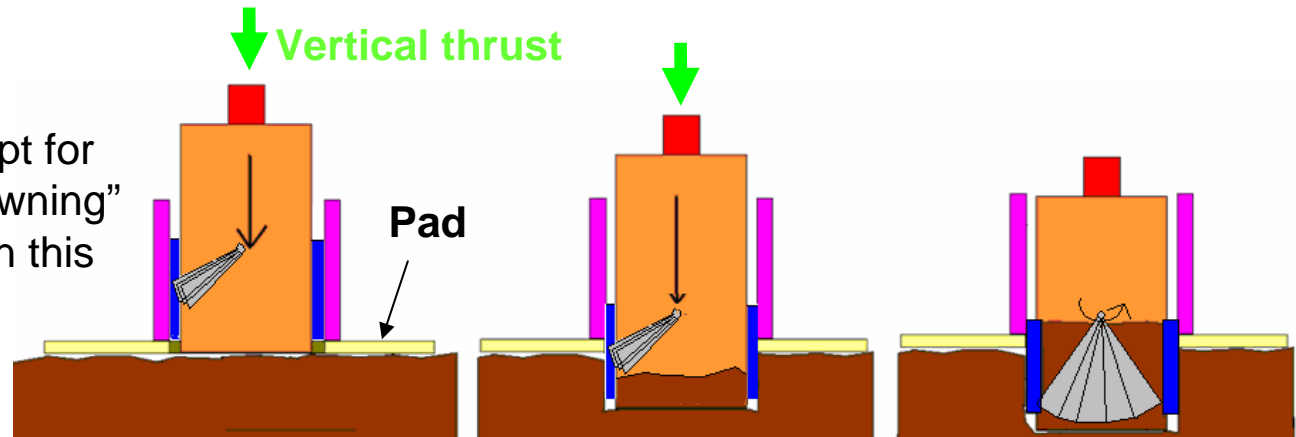

Expected sampling performance in asteroid reference material

- Total sampling time:  $\approx 1-5$  s
- Required vertical thrust: 80 – 120 N
- Amount of collected material: at least 30 g

### Example of sampling method: Fast shallow corer

The Fast shallow corer type tool is compatible with a *landing short stay* type mission

The system is composed by two connectable / detachable parts:

- the tool drive
- the fast corer tool proper

The *tool drive* is firmly attached to a sampling/transport arm and contains two independent actuation in order to perform the tool hold/release functions and the actuation of the occluding mechanism (embedded in the tool proper)

The *fast corer tool proper* is in charge of the real sample material collection, via rotary coring action, and (first) containment and is the part being repositioned back (filled with collected material) for return to earth.

### Fast Shallow Corer – schematics

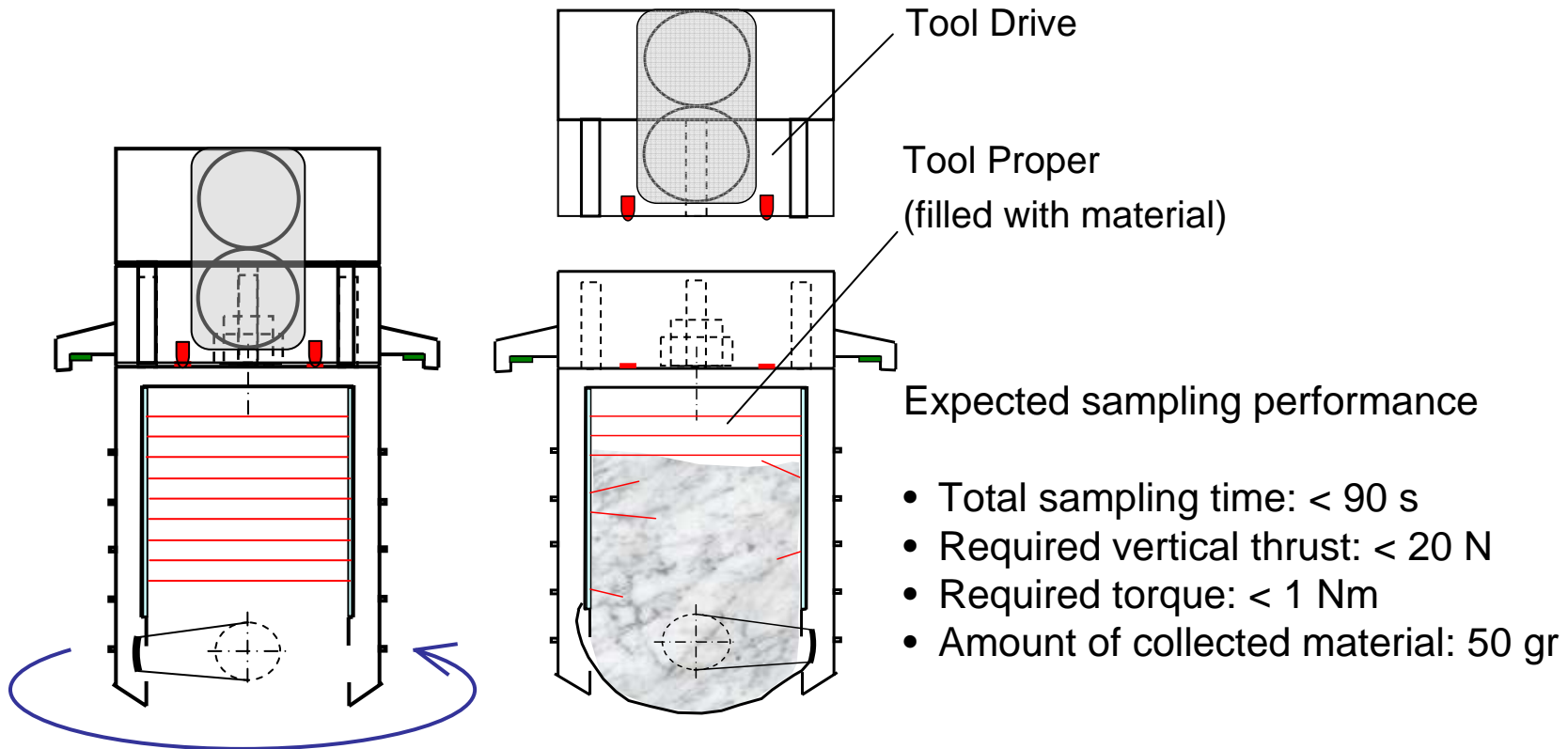

*Schematics of fast shallow corer*



CNSR Drill tool

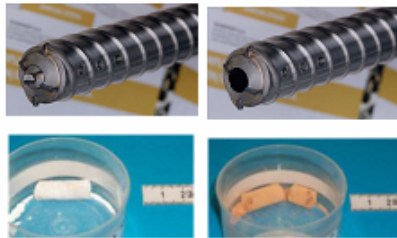

Deedri/Exomars type drill tools



Rosetta SD2 Drill tool

## CNSR Drill Tool

- Prototype level
- Sample Size: diameter 100 mm – length 1000 mm
- Temperature: down to  $-150^{\circ}\text{C}$

## ExoMars Drill Tool

- EM level
- Sample Size: diameter 10 mm – length 25 mm
- Temperature: down to  $-80^{\circ}\text{C}$

## Rosetta SD2 Drill Tool

- Flight Model (in flight; landing date: 2014)
- Sample Size: diameter 2,5 mm – length 5 mm
- Temperature: down to  $-150^{\circ}\text{C}$



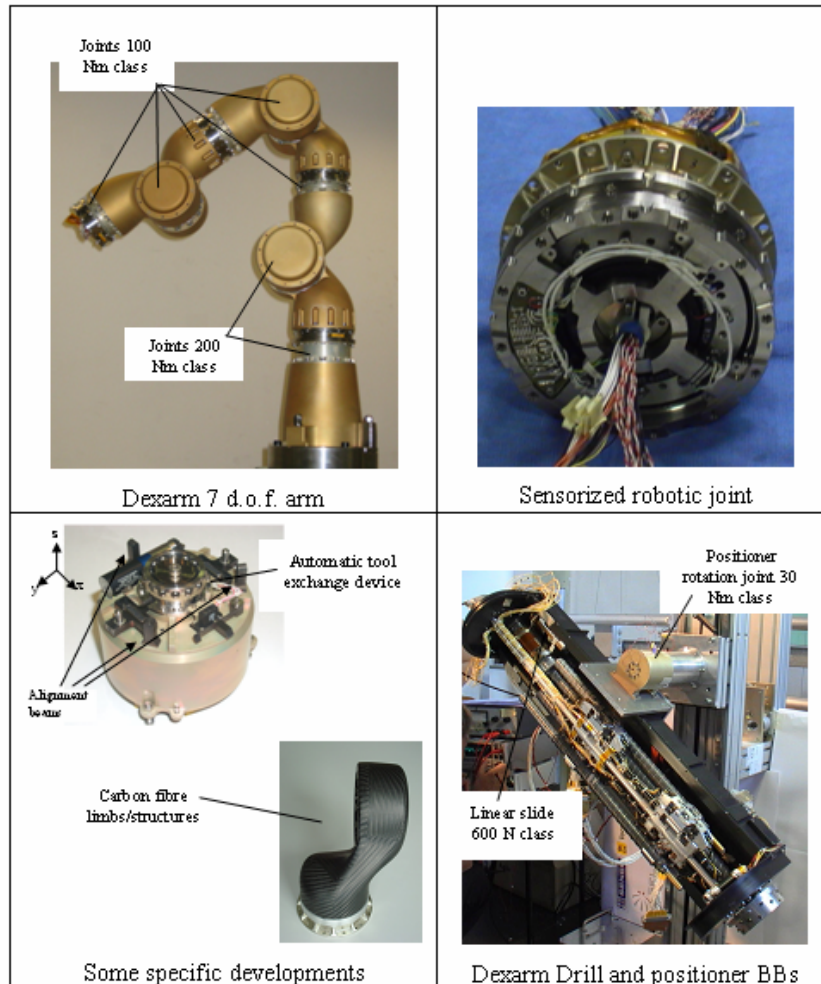

## Dexarm

- Engineering Model Level
- 7 d.o.f. arm: human like
- Length 1,2 m, 10 kg load capability in 1g
- Arm mass: 25 kg

## Automated tool change device

- Engineering Model Level
- Capability to perform end effector/tools automatic exchange
- To be installed at the end of Dexarm Robotic Arm
- Tool exchange device mass: 0,9 kg

## ExoMars Positioning Joints

- Engineering Model Level
- Rotation and translation type joint
- To be installed between Rover and ExoMars Drill Box (mass: 12 kg)

The general experience in sampling systems and the outcomes of the on-going activities give confidence on the capability to collect the amount of material required for small body sample return missions in general and Marco Polo in particular.

In this respect sampling systems of volumetric type, with the capability to check the actual presence of material, appears to be good candidates.

Breadboarding and extensive testing of the most critical items of sampling tools is any how essential to achieve proper confidence on the sampling operation in sampling environment.