

Solar Orbiter

Assessment Phase Final Executive Report

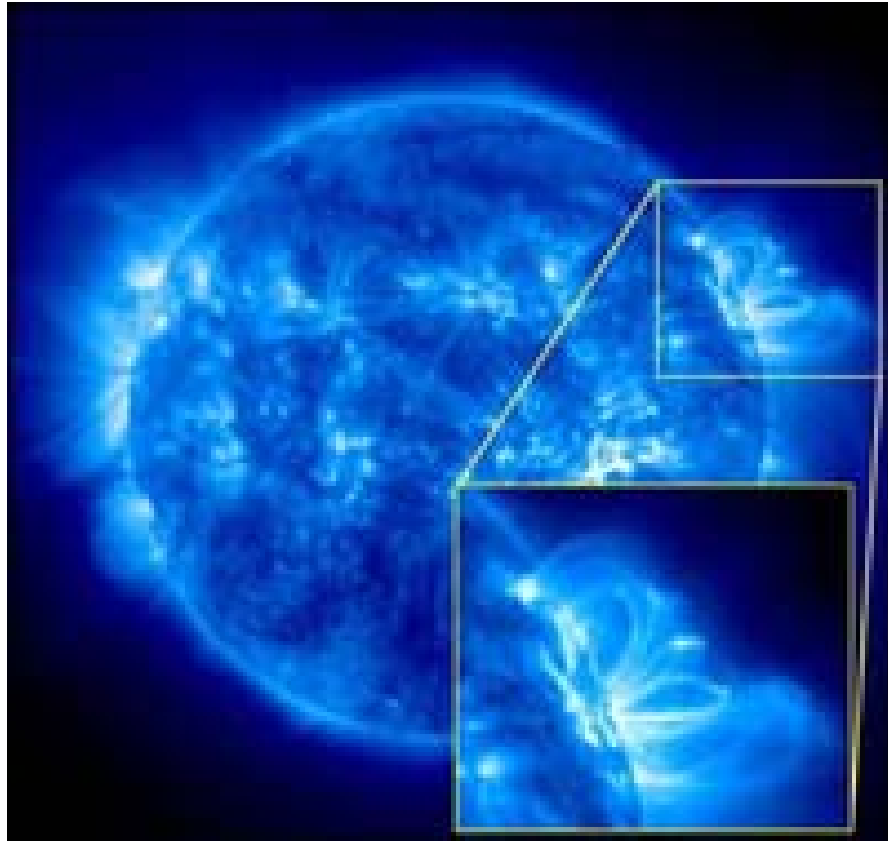

prepared by/ <i>préparé par</i>	SCI-AM
Reference/ <i>référence</i>	SCI-A/2005/054/NR
issue/ <i>édition</i>	2
revision/ <i>révision</i>	0
Date of issue/ <i>date d'édition</i>	15 December 2005
status/ <i>état</i>	Final
Document type/ <i>type de document</i>	Open
Distribution/ <i>distribution</i>	

D I S T R I B U T I O N

Name	Organisation
Open distribution	

C H A N G E L O G

Reason for change	Issue	Revision	Date
Completion of delta activities on ballistic transfer scenario	2	0	14 Dec 05

A U T H O R I Z A T I O N R E C O R D

Prepared by SCI-AM		Date
Authorised by SCI-A		13 Dec 2005

A C K N O W L E D G E M E N T S

SCI-A team	N.Rando, A.Jeanes, A.Lyngvi, A.Owens.	
SCI-SH	R.Marsden	
D-TEC	L.Gerlach, P.Ponzio	
D-OPS	G.Janin, A.Boutonnet, JL.Pellon	
EADS Astrium consortium	P.Regnier (EADS-ASF)	
Alcatel Alenia Space consortium	F.Jubineau (AAS)	

T A B L E O F C O N T E N T S

List of acronyms:.....	4
List of reference documents:.....	4
1 Introduction.....	5
2 Assessment study goals and activities	6
3 Science requirements	7
4 Mission requirements.....	8
5 Definition of the reference payload.....	8
5.1 The process.....	9
5.2 The Payload Definition Document.....	11
5.3 Payload procurement aspects.....	11
5.4 Payload accommodation aspects	12
6 Mission profiles	14
6.1 Ballistic transfer – 2013 launch.....	15
6.2 Ballistic transfer – 2015 launch.....	17
6.3 Ballistic transfer – 2017 launch.....	17
6.4 Note on residual System Level (Mass) Margins	20
6.5 Consequences for Reference Payload.....	20
6.6 Launcher.....	20
6.7 Spacecraft design and industrial activities.....	20
6.8 Ground segment.....	23
7 Technology assessment – development	23
7.1 Payload	23
7.2 Spacecraft	24
7.3 Link to BepiColombo TDP.....	24
8 International cooperation	25
9 Risk assessment	25
10 Cost assessment.....	26
10.1 CaC and link to BepiColombo.....	26
11 Development schedule	26
12 Link to BepiColombo.....	28
13 Conclusions.....	29
14 Recommendations	30

LIST OF ACRONYMS:

AAS:	Alcatel Alenia Space
AD:	Applicable Document
AO:	Announcement of Opportunity
ASF:	EADS – Astrium (F)
CaC:	Cost at Completion
CCN:	Change Contract Notice
CDF:	Concurrent Design Facility
C/OM:	Cruise/Orbiter Module
CP:	Chemical Propulsion
CSG:	Centre Spatial Guinea
FDIR:	Failure Detection Isolation & Recovery
GAM:	Gravity Assist Manoeuvre
HEO:	Highly Elliptical Orbit
ITT:	Invitation To Tender
IS:	In Situ
LSB:	Lunar Swing By
LV:	Launcher Vehicle
MOC:	Mission Operations Centre
OM:	Orbiter Module
PI:	Principal Investigator
P/L:	Payload
PSE:	Payload Support Elements
RA:	Risk Assessment
RS:	Remote Sensing
S/C:	Spacecraft
SEP/M:	Solar Electric Propulsion / Module
SLM:	System Level Margin
SOC:	Science Operations Centre
SSAC:	Space Science Advisory Committee
TDA:	technology Development Activity

LIST OF REFERENCE DOCUMENTS:

- [RD-SciRD] Science Requirements Document – v1.2 – March 2005
[RD – MRD] Mission Requirements Document – v2.1 – March 2005
[RD-PDD] Payload Definition Document – v4.1 – August 2005
[RD-MA] Mission analysis – ESOC WP 483 – October 2005
[RD-SRD] ESA System Design Report
[RD-MOC] ESA Mission Operations Concept document
[RD-TDP] ESA Technology Development Plan
[RD-CA] ESA Cost Assessment Report
[RD-RA] ESA Risk Assessment Report
[RD-SciMP] ESA Science Management Plan, draft – October 2005
[RD-SAN] ESOC Mission Assumptions Document, October 2005
[RD-EXR] Executive Report – ref. SCI-A/2005/023/NR, April 2005.
[RD-CDF1] Solar Orbiter – CDF study report CDF-02(A), December 1999.
[RD-CDF2] Solar Orbiter 2 – CDF study report CDF-25(A), April 2004.
[RD-ASFP] EADS-Astrium Final Presentation – CCN – 30 Sep 2005
[RD-AAFP] Alcatel-Alenia Final Presentation – CCN – 29 Sep 2005

1 INTRODUCTION

The Solar Orbiter mission was first discussed at the Tenerife “Crossroads” workshop in 1998, in the framework of the ESA Solar Physics Planning Group. Following a pre-assessment study in ESA’s Concurrent Design Facility in 1999 [RD-CDF1], the mission was submitted to ESA in 2000 in response to a call for proposals for two *Science Flexi missions* (F2 and F3). Solar Orbiter was selected by ESA’s Science Programme Committee in October 2000 to be implemented as a flexi-mission, with a launch envisaged in the 2008-2013 timeframe (after the BepiColombo mission to Mercury). The mission was subsequently re-confirmed by the SPC in May 2002 on the basis of implementation as a mission group together with BepiColombo. A re-assessment of BepiColombo was conducted in 2003, leading to an SPC decision in November 2003 to maintain Solar Orbiter in the Cosmic Vision programme, and to begin an assessment study of Solar Orbiter. At its 107th meeting on 7-8 June 2004, the SPC endorsed the recommendations of the advisory bodies (SSWG and SSAC), and confirmed the place of Solar Orbiter in the Cosmic Vision programme, with the objective of a launch in October 2013 and no later than May 2015.

The Solar Orbiter mission will provide the next major step forward in the exploration of the Sun and the heliosphere to solve many of the fundamental problems remaining in solar and heliospheric science. It incorporates both a near-Sun and a high-latitude phase. The near-Sun phase of the mission enables the Orbiter spacecraft to approach the Sun as close as 48 solar radii (~ 0.22 AU) during part of its orbit, thereby permitting observations from a quasi-helio-synchronous vantage point (so-called co-rotation.). At these distances, the angular speed of a spacecraft near its perihelion approximately matches the rotation rate of the Sun, enabling instruments to track a given point on the Sun surface for several days. During the out-of-ecliptic phase of the mission (extended mission), the Orbiter will reach modest solar latitudes (up to 34° in the extended phase), making possible detailed studies of the Sun’s polar caps by the remote-sensing instruments.

This report provides a summary of the delta activities of the assessment study conducted by the Science Payload and Advanced Concepts Office (Science Missions section) from May 2005 to September 2005 on the Chemical Profile scenario. Detailed information on both technical and programmatic matters, based on the delta activities performed by industry in the context of two parallel, competitive studies can be found in the reference documents listed on page 4. A summary of the results of the work conducted during the main contract activities (focused on the SEP mission profile) are to be found in [RD-EXR, v1.0], issued in April 2005.

The extension of the industrial studies had the following objectives: a) take into account latest ballistic transfer trajectories and confirm their suitability; b) based on those, finalize the S/C design; c) address a few critical areas highlighted during the previous activities; d) consolidate the P/L to S/C interfaces in preparation to the future instrument AO; e) take into account the most recent evolution of the BepiColombo project. During the study specific emphasis has been given to: a) maximizing the re-use of existing functional elements with flight heritage (not just from BepiColombo); b) minimizing development risks and cost; c) identifying a single S/C design compatible with different launch dates.

An unusually high definition level has been achieved for the Solar Orbiter mission due to the activities already performed for BepiColombo, the previous main contract work and focus on the chemical profile, leading to a realistic and robust programme, ready for entering the Definition Phase. Based on the work performed, final recommendations are made as to allow the ESA management to proceed with relevant decisions, in view of defining the future of the Solar Orbiter mission.

2 ASSESSMENT STUDY GOALS AND ACTIVITIES

The goals of the Solar Orbiter assessment study are briefly recalled below:

- Consolidation of the science requirements.
- Definition of the mission requirements enabling the platform definition.
- Identification and down-selection of optimal mission profiles.
- Further maturing and definition of the reference payload.
- Preliminary definition of the flight segment design through industrial work and confirmation of overall feasibility and potential technology development needs.
- Preliminary definition of the ground segment requirements, of the mission and of the science operations requirements (with emphasis on BepiColombo commonality).
- Identification and analysis of most critical areas, design and cost drivers.
- Identification of BepiColombo commonalities and determination of reference development plan relevant to the preparation of the BepiColombo ITT (mission group).
- Assessment of overall development risks and Cost at Completion (CaC).

In order to achieve these goals, the following activities have been performed within the Science Payload and Advanced Concept Office (SCI-AM, Science Missions section):

- Preparation of all reference and applicable documents required for the study.
- Dedicated mission analysis and ground segment definition activities with ESOC starting as from Feb 04 and extending to Q1/2005.
- A reduced Concurrent Design Facility session (Mar 04) to verify the overall feasibility of the electric profile, assuming a fully recurrent BepiColombo SEPM [RD-CDF2].
- An industrial study aiming to verify the resources required by the payload and to consolidate its interfaces to the platform (Jan to Jun 04 – ASF).
- Two industrial, parallel-competitive system assessment studies (ASF and AAS, May to Jan 2005).
- Additional activities on chemical profile (CCN) (May to September 2005).
- Numerous iterations with the scientific community on the reference payload, to trigger further definition and consolidation of critical areas [RD-PDD].
- Preparation of the Science Management Plan [RD-SciMP].
- Compilation of a specific Solar Orbiter Technology Development Plan [RD-TDP].
- Risk and Cost at Completion assessments in cooperation with Sci-C and D-TEC.

The assessment study has followed a top-down approach, from the science requirements, down to the mission specification and the system definition. A Design-To-Cost approach has been imposed to minimise the target CaC, while maximum re-use of existing equipment with flight heritage (not just from the BepiColombo mission) has been promoted (also beneficial to containing costs). Large emphasis has been put on the consolidation of the reference payload, in view of adequately preparing the way for the forthcoming Announcement of Opportunity for the provision of the instruments. Specific attention has been given to risk identification and risk mitigation, in the frame of a ‘medium size-mission’ budget. Finally, frequent and productive contacts have been maintained with the BepiColombo project team to guarantee overall consistency within the mission group.

3 SCIENCE REQUIREMENTS

The Sun's atmosphere and the heliosphere represent uniquely accessible domains of space, where fundamental physical processes common to solar, astrophysical and laboratory plasmas can be studied under conditions impossible to reproduce on Earth or to study from astronomical distances. The results from missions such as Helios, Ulysses, Yohkoh, SOHO, TRACE and RHESSI have advanced significantly our understanding of the solar corona, the associated solar wind and the three-dimensional heliosphere. Further progress is to be expected with the launch of STEREO, Solar-B, and the first of NASA's Living With a Star (LWS) missions, the Solar Dynamics Observatory (SDO). Each of these missions has a specific focus, being part of an overall strategy of coordinated solar and heliospheric research. An important element of this strategy, however, has yet to be implemented. We have reached the point where further *in-situ* measurements, now much closer to the Sun, together with high-resolution imaging and spectroscopy from a near-Sun and out-of-ecliptic perspective, promise to bring about major breakthroughs in solar and heliospheric physics. The Solar Orbiter will, through a novel orbital design and an advanced suite of scientific instruments, provide the required observations. The unique mission profile of Solar Orbiter will, for the first time, make it possible to:

- Explore the uncharted innermost regions of our solar system;
- Study the Sun from close-up;
- Fly by the Sun tuned to its rotation and examine the solar surface and the space above from a co-rotating vantage point;
- Provide images & spectral observations of the Sun polar regions from out of the ecliptic

Within the framework of the global strategy outlined above, the top-level scientific goals of the Solar Orbiter mission are to [RD-SciRD]:

- Determine the properties, dynamics and interactions of plasma, fields and particles in the near-Sun heliosphere;
- Investigate the links between the solar surface, corona and inner heliosphere;
- Explore, at all latitudes, the energetics, dynamics and fine-scale structure of the Sun's magnetized atmosphere;
- Probe the solar dynamo by observing the Sun's high-latitude field, flows and seismic waves.

The latest version of the Science Requirements Document was approved by the Solar Orbiter Science Definition Team in March 2005.

4 MISSION REQUIREMENTS

The main missions requirements are summarised below. The complete set of requirements that were applied to the system level study is described in [RD-MRD].

- Launcher vehicle is Soyuz Fregat 2-1B (from CSG).
- Total cruise duration shorter than 3 years (goal).
- Orbital period in 3:2 resonance with Venus.
- At least one orbit with perihelion radius < 0.25 AU and > 0.20 AU (science phase).
- Inclination with respect to solar equator increasing to a minimum of 30 deg.
- During the extended operational lifetime, the Solar Orbiter operational orbit shall reach an inclination with respect to solar equator not lower than 35 deg (goal).
- Support a payload of 180 kg and 180 W (including 20% maturity margins).
- Provide onboard mass memory and communications with a single ground station (New Norcia) as to support the science observations specified in [RD-SciRD].
- Fail-safe on-board autonomous operations during the perihelion passages (15 days without ground contact, in extremely harsh thermal environment).
- Use of functional elements of BepiColombo and other ESA missions to reduce cost in order to meet CaC allocation.

5 DEFINITION OF THE REFERENCE PAYLOAD

The actual scientific payload for the Solar Orbiter mission will be selected on a competitive basis, following an Announcement of Opportunity that will be open to the international scientific community. In order to proceed with the assessment study at system level in an effective manner, it was decided to establish Payload Working Groups with membership from the science community, whose task was to provide detailed input on the design and resource requirements of representative (and state-of-the-art) instruments for the so-called reference payload. The reference payload comprises instruments that satisfy in-situ and remote-sensing measurement requirements as defined in [SciRD].

A summary of the Solar Orbiter reference payload [RD-PDD] is provided in the table below. Three categories are identified: a) In-Situ sensor units; b) Remote-Sensing units; c) Payload Support Elements (e.g. boom, instrument doors, Remote Terminal Units, etc.).

The table refers to the *core payload complement*, reflecting the science prioritisation given in [RD-SciRD]. All figures reported in the table include design maturity margins varying between 10% (typically IS units) and 25% (typically RS units), depending on actual heritage.

Table 4.1 – Summary of the Solar Orbiter reference payload [RD-PDD].

Instrument	Acronym	Mass [kg]	Power [W]	Accommodation / remarks
a) In-Situ instruments				
Solar Wind Plasma Analyzer	SWA	16.5	15.5	PAS and HIS are S/C body mounted with aperture through the heat shield, EAS1 on the boom, EAS2 is behind the shield
Radio and Plasma Wave Analyzer	RPW	13.0	7.0	3 × antenna on S/C, magnetometer loop and 3x search coils on the boom
Magnetometer	MAG	2.1	1.5	2× sensors located on boom (in the shadow)
Energetic Particle Detector	EPD	9.0	8.5	5× sensors on S/C body, located behind the heat shield.
Dust Particle Detector	DPD	1.8	6	2 sensors mounted on the S/C body in velocity and orthogonal to velocity direction
Neutron Gamma ray Detector	NGD	5.5	5.5	Located behind shield, no optical aperture is required (but low Z materials)
b) Remote-Sensing instruments				
Visible Imager & Magnetograph	VIM	30.4	35	Located behind shield, 2 apertures with covers and heat rejection filters
EUV Spectrometer	EUS	18.0	25	Located behind shield, 1 aperture (6 cm diameter) with cover
EUV Imager	EUI	20.4	28	Located behind shield, up to 4 apertures with covers, baffles – thin Al filters
VIS Coronagraph	COR	18.3	30	Located behind shield, 1 aperture with cover and occulter – optional EUV channel
Spectrometer Telescope Imaging X-ray	STIX	4.4	4	Located behind shield, 1 apertures with cover and filters
c) Payload Support Elements	PSE	28.4	4	Scanning platform, boom, doors/windows and specific P/L thermal HW
TOTAL	---	167.8	170.0	Compliant with MRD requirement

5.1 The process

The reference payload plays a key role in determining the platform resources and performance. A realistic estimate of the instrument requirements is thus critical. In order to consolidate such requirements, a preliminary industrial study (EADS-Astrium, Jan-Jun 2004) was conducted to assess the actual resources required by the payload and to identify a *resource efficient* payload complement, in line with the boundary conditions applying to a medium size mission.

In the case of the Remote Sensing instruments (the most demanding in resource terms), the contractor has developed model designs, which have allowed determining the required resources in a realistic way, without the need to wait for detailed design information from the actual instrument teams (not available until after the AO). Examples of such model designs are shown in the figures 4.1.1 (VIM), 4.1.2 (EUS). Figure 4.1.3 shows how the RPW antennas could look like (courtesy of Dr. S.Bale – University of California).

On the basis of the results of such a study a new issue of the Payload Definition Document was released (v3), triggering further iterations with the scientific community, through the IS and RS Payload Working Group chairmen. Following the conclusions of the system level studies (Jan 05) and numerous interactions with several representatives of the scientific community, PDD v4 was released [RD-PDD]. During the course of the delta-activities on the ballistic transfer, additional input has been receiving, leading to PDD v4.1: this last issue has been formally approved by the PLWG, thus triggering the approval of the Science Management Plan and the preparation for the instruments Announcement of Opportunity. A final version of the PDD (v5) is planned before issuing the instrument AO.

Figure 4.1.1 – Model design for the Visible Imager Magnetograph (VIM)

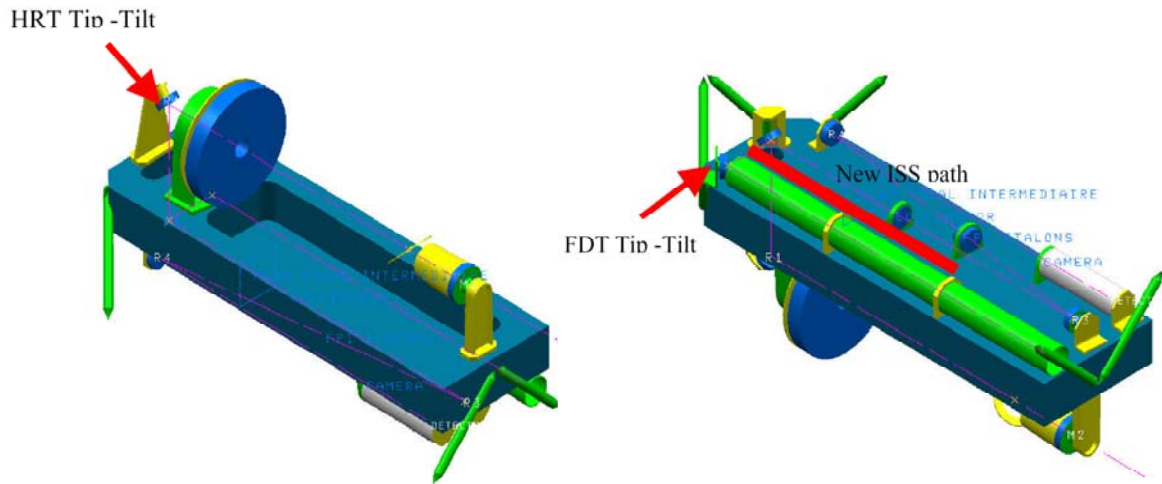

Figure 4.1.2 – Model design for the High Resolution Telescope of the EUV Imager (EUI)

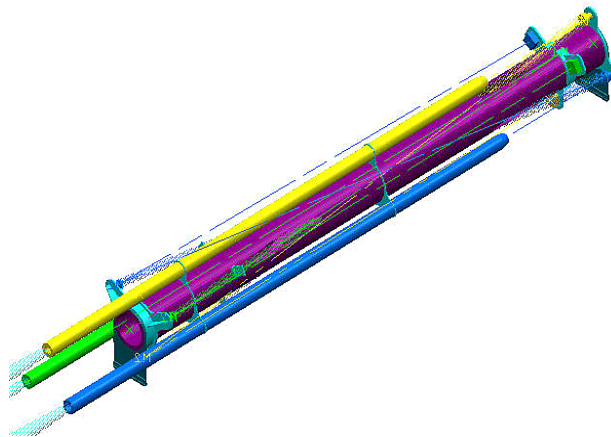
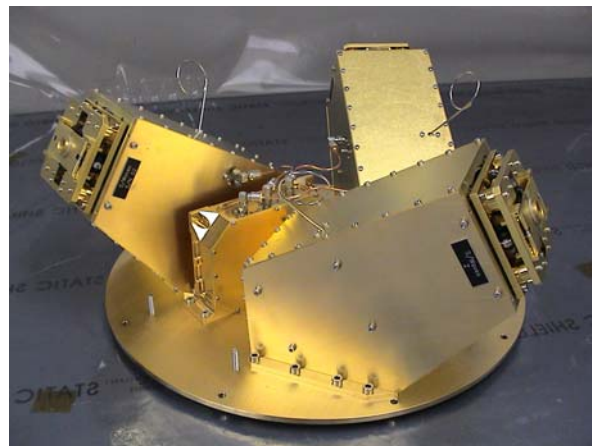

Figure 4.1.3 – RPW antenna assembly before deployment.



5.2 The Payload Definition Document

A new version of the PDD (v4.1) has been released and approved by the PLWG. Considerable effort has been put in establishing realistic reference designs and corresponding resource estimates, without pre-empting the future AO. In order to produce a balanced picture and to prepare adequately for the future Announcement of Opportunity, the specific resource demands from the external community have been weighted against the available resources and independent estimates. During the whole process, special emphasis has been given to maintaining a constructive dialogue with the science community representatives.

The key features of the reference payload complement are: 1) the '1 arcsec, 1m class' Remote Sensing instruments (representing the maximum allowed envelope for the biggest units); 2) the definition of In-Situ sensors and how best to accommodate them; 3) the explicit inclusion of 'Payload Support Elements' (such as boom, Remote Terminal Units, instrument doors, etc.).

[RD-PDD] addresses a number of issues related to S/C interfaces (e.g. thermal control, DHS, accommodation) and potential ESA provided items as to provide relevant information for an adequate AO preparation. A Preliminary Instrument Interface Document (IID) has been prepared and openly distributed to summarise the results of the industrial activities with respect to payload interfaces. The release of a new PDD version (v5) is planned as to provide adequate information for the submission of the AO proposals and include the latest results of the industrial activities.

5.3 Payload procurement aspects

The preparation of the PDD has assumed a classic approach for the procurement of the instruments, based on a competitive AO open to potential international partners [RD-SciMP]. Based on preliminary indications from the scientific community, a certain level of competition regarding a limited number of instruments is expected. The payload AO will be formulated in such a way as to maintain a close link with the PDD and to ensure compatibility with the available S/C resources. Procurement of individual units is baselined for the larger Remote-Sensing units, while the smaller In-Situ sensors might be integrated in suites. A number of ESA provided items are proposed in order to reduce the overall development risk and to maintain consistency with the platform interfaces. A summary of the items proposed for ESA procurement is given in the table 4.3 below:

Table 4.3: Payload related items proposed as ESA provided.

Item	Remarks	Justification
Remote Terminal Control - RTC	ASIC to be used for instrument ICU and SpaceWire interface	Standard interfaces and processor – reduced risk from common procurement
Power Converter (DC/DC)	Provision of components – as CPPS	Standard interfaces – reduced risk from common procurement
Magnetometer Boom	2 segment boom, 4m – hosting several sensors (boom suite)	Close I/F to platform – full control over design
VIM heat rejecting window	Critical elements to both VIM instrument and platform TCS	Close I/F to platform heat shield – full control over design
Instrument doors / baffles	Critical elements to several instrument and platform TCS	Close I/F to platform heat shield – full control over design

Under the assumption of an SPC approval of the Science Management Plan in February 2006, it is presently considered to release the instrument AO in the second quarter of 2006.

5.4 Payload accommodation aspects

The Solar Orbiter will be a three-axis stabilised spacecraft, with the main body permanently maintained in the shade by a dedicated heat shield. Details are provided in [RD-PDD]. The main characteristics of the proposed accommodation (see figures 4.4.1 and 4.4.2 below) are:

- The overall philosophy to minimise / intercept heat loads at the instrument apertures by reducing the size of the apertures and through externally mounted, heat rejecting elements and baffles.
- The installation of all Remote Sensing instruments inside the S/C body and behind the heat shield, on lateral or shear panels to guarantee: a) controlled thermal environment; b) easy access to the S/C radiators; c) stiff mechanical support to meet the co-alignment requirement; d) additional radiation shielding.
- The installation of the In-Situ payload elements in different locations depending on actual FOV requirements: a) sun-pointing through the heat shield; b) boom mounted; c) S/C body mounted. Note that the rotating platform initially envisaged for the EPD sensors, following dedicated studies, is not part of the baseline design.

Key issues addressed in the additional industrial work are: a) the interface between instrument apertures and heat shield (e.g. instrument doors/baffles); b) the accommodation of the EPD sensors on the S/C body; c) the confirmation of the SpaceWire interface between the instruments and the platform DHS; d) more detailed thermal analysis of the RS instruments and related interfaces to the spacecraft TCS; e) preliminary Electro-Magnetic cleanliness analysis (see magnetometer) and f) contamination analysis.

Figure 4.4.1 – Solar Orbiter payload accommodation.

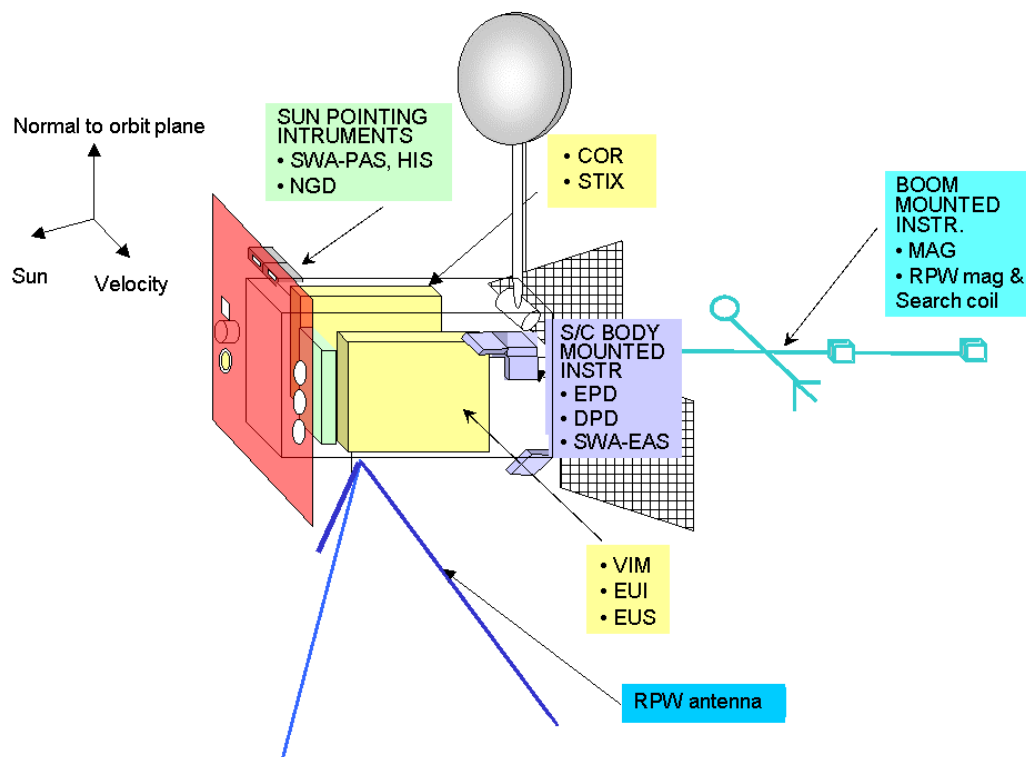
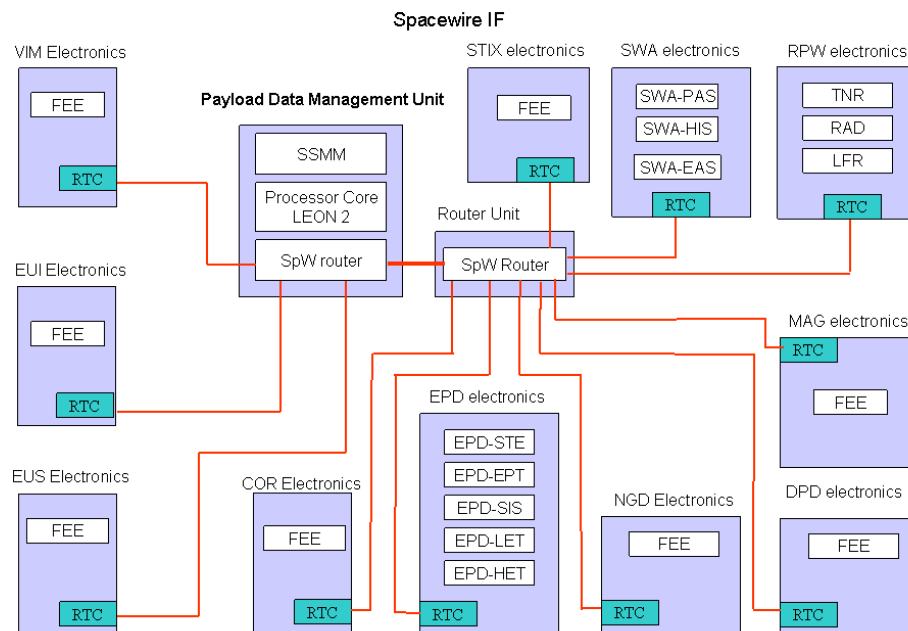

Figure 4.4.2 – Baselined interface between instruments and platform DHS through a Payload dedicated Data Management Unit and the adoption of SpaceWire IF.



- Interface between heat shield and instruments: the use of specific ceramic or metallic baffles is required to interface the aperture of the RS instruments to the heat shield. Multiple-operation doors integrated into the baffle design are also baselined.
- Accommodation of the EPD sensors on the S/C body: specific analysis showed that the rotating platform initially envisaged would introduce pointing stability disturbances, potential EMC issues and additional cost and complexity. Body mounting of EPD sensors is compatible with the science needs and is baselined.
- SpaceWire interface: this solution is baselined for BepiColombo and baselined for the Solar Orbiter on the basis of standardisation.
- Thermal analysis of the RS instruments: simplified FEA models have been constructed, including relevant interfaces to the spacecraft TCS. The analysis showed compatibility with the instrument requirements and S/C budgets. Mounting on lateral panels and use of thermal connections to S/C-provided radiators are assumed.
- Electro-Magnetic cleanliness: a preliminary analysis showed the severity of the MAG requirements and the need to include EMC considerations early on in the programme. S/C configuration is affected with optimised SA position and a boom length of 5 m. Spacecraft charging effects and related requirements are also calling for specific attention.
- Contamination: proposed contamination requirements are considered as very severe, impacting on AIV/T procedures. Reaction Wheel de-saturation strategy as well as position and orientation of thrusters have been optimised to minimise the risk of contamination. Engineering estimates based on data from previous programmes showed that propellant induced contamination can be virtually eliminated by optimising location and orientation of the thrusters.

6 MISSION PROFILES

The Solar Orbiter mission design is based on a *transfer phase* and an *inclination-raising phase* (core of the science operations). The transfer phase comprises the Earth escape and a trajectory that remains close to the ecliptic in order to bring the Orbiter into a Venus resonant orbit. The overall mission design aims to reduce the perihelion distance (permitting the Orbiter to move in near-synchronism with the solar surface for periods of a few days), and to gradually increase the orbital inclination to more than 30 degree with respect to the solar equator through repeated Venus gravity assist manouvres (GAM).

During the first part of the study alternative mission profiles have been examined for the transfer (or cruise) phase, without affecting the inclination-raising phase. Given the strong link to BepiColombo and the benefits of a shorter cruise phase, more emphasis was initially given to the so-called '*baseline profile*', assuming Solar Electric Propulsion (SEP). The delta activities have entirely focused on the chemical profile (covering different launch opportunities in 2013, 2015 and 2017).

All profiles assume launch from CSG on a Soyuz Fregat type 2-1B and a 3-week launch window. Launch dates are governed by the Venus synodic period (~19 months).

The table below summarises the key events for each profile.

Mission duration (yr)	a) SEP profile	b) Chemical (2013, CP)	c) Chemical (2015, CP)	d) Chemical (2017 CP)
Launch date	19 Oct 2013	16 Oct 2013	15 May 2015	11 Jan 2017
Transfer	1.82	3.37	3.39	4.10
Science nom.	2.80	2.74	2.74	3.47
Science ext.	2.43	3.73	3.75	3.63
Total	7.05	9.84	9.88	11.20
S/C config.	SEPM+OM	C/OM	C/OM	C/OM

The SEP Profile has been addressed in detail during the main contract activities and it is reported here only for comparison purposes. Profiles b) to d) have been the subject of the delta activities and are summarised in the next sections. The spacecraft configurations envisaged for option b), c) and d) are identical and consists of a single spacecraft (combined Cruise/Orbiter Module – C/OM), with tank capacity adapted to the different delta-V. All ballistic transfer profiles are compatible with the use of a monopropellant propulsion scheme.

The science phase orbit (starting with the second Venus GAM, V2) remains basically unchanged for all profiles: in all cases the trajectory is based on a 3:2 Venus resonant orbit (i.e. 3 S/C orbits around the Sun in 450 days, corresponding to 2 Venus orbital periods) and its key parameters (minimum perihelion distance and maximum heliospheric latitude) are determined by the entry velocity vector (amplitude and angle) at GAM V2. Finally, the co-rotation parameter (relative angular speed between Sun and S/C) is determined once the perihelion distance is fixed. Option d) (back-up only) is characterised by a longer transfer and by the need of one more revolution around the Sun after GAM V2 to achieve the 3:2 resonance.

It is also useful to recall that the solar cycle will be close to its peak in 2021, while from a science point of view, it would be preferable to view the Sun's polar regions from an out of ecliptic perspective near solar minimum.

Based on the delta assessment activities, the ballistic transfer option (*chemical*) has been identified as most appropriate (and is described further in the next sections), while option a) is found to be characterised by considerably higher development risk and cost, not compatible with the boundaries of a medium class mission.

6.1 Ballistic transfer – 2013 launch

In December 2004 ESOC identified the existence of ballistic transfer trajectories with reduced transfer time (about 3.5 yr) and acceptable mass performance (always assuming launch on a SF-2 - 1B). Such trajectories were also found compatible with the science requirements and thus used as basis for the additional industrial activities, from April to September 2005. The first launch scenario to be investigated is October 2013. The key events of the scenario are provided in Table 6.1 (GAM = Gravity Assist Manoeuvre; DSM = Deep Space Manoeuvre; ENM=End of Nominal Mission; EXM = End of Extended Mission; EOM= End Of Mission).

Table 6.1: Summary of chemical profile (2013 launch).

	Date	Flight time		Event	Inclination [°]		Aphelion [AU]	Perihelion		
		Days	Years		Ecliptic	Sol. equ.		[AU]	[Sol. rad.]	
	2013-10-23	0	0	Launch	1.3	6.4	0.999	0.678	146	
	2014-04-24	182	0.50	GAM V1	1.2	7.1	1.379	0.725	156	
	2014-10-10	351	0.96	DSM 1	1.2	7.1	1.379	0.725	156	
	2015-03-06	499	1.37	GAM E1	0.0	7.3	1.104	0.463	100	Transfer Phase
	2016-12-29	1163	3.18	GAM E2	4.1	3.8	0.990	0.294	63	
	2017-03-04	1228	3.36	GAM V2	5.2	7.0	0.880	0.224	48	
Science Phase	2018-05-30	1679	4.60	GAM V3	14.5	16.4	0.860	0.244	53	
	2019-08-20	2127	5.82	GAM V4	22.5	24.4	0.822	0.282	61	
	2019-11-27	2226	6.09	ENM	22.5	24.4	0.822	0.282	61	
Extended Mission	2020-11-11	2576	7.05	GAM V5	28.1	30.0	0.775	0.329	71	
	2022-02-04	3025	8.28	GAM V6	31.3	33.1	0.733	0.371	80	
	2022-05-29	3139	8.60	EXM	31.3	33.1	0.733	0.371	80	
	2023-04-29	3475	9.51	GAM V7	32.1	34.0	0.719	0.385	83	
	2023-08-27	3595	9.84	EOM	32.1	34.0	0.719	0.385	83	

The actual trajectory to be followed by the spacecraft is represented in figures 6.1.1 (projection on the ecliptic plane) and 6.1.2 (projection on the perpendicular plane).

The ecliptic view shows the S/C trajectory in the inner Solar system during the transfer phase, from launch to the second Venus GAM. The Deep Space Manoeuvre is indicated with a green triangle. The Earth orbit is shown in blue. Venus' orbit is in yellow. The trajectory followed during the science phase is indicated in red. No navigation manoeuvres are expected at $d < 0.6$ AU from the Sun. The Y-Z projection shows the evolution of the trajectory in a plane perpendicular to the ecliptic as to highlight the progressive inclination increase at each Venus GAM. Maximum orbit inclination and minimum perihelion distance are compatible with the science goals. The total delta-V is limited to about 600 m/s, fully compatible with CP.

It should be noted that, differently from the SEP profile, it would be possible to operate both In-Situ and Remote Sensing instruments during the transfer phase. It is envisioned to have continuous operation of the IS instruments during transfer, while the RS instruments will be operated during specific windows, compatibly with the distance from the Sun. Suitable windows for instrument commissioning have also been identified, taking benefit from a reduced distance to Earth, thus maximising the available TM link performance. This operational aspect has been taken into account in the recent industrial activities.

Due to the possibility to operate the instruments during the transfer phase, the mission phases are now defined as: 1) Nominal Mission (including transfer phase and nominal science phase, including one perihelion and maximum latitude after GAM V4, until the End of Nominal Mission, ENM); 2) Extended Mission (including the extended science phase, post GAM V4).

Figure 6.1.1/2: Chemical trajectory (2013 - ecliptic view and Y-Z projection)

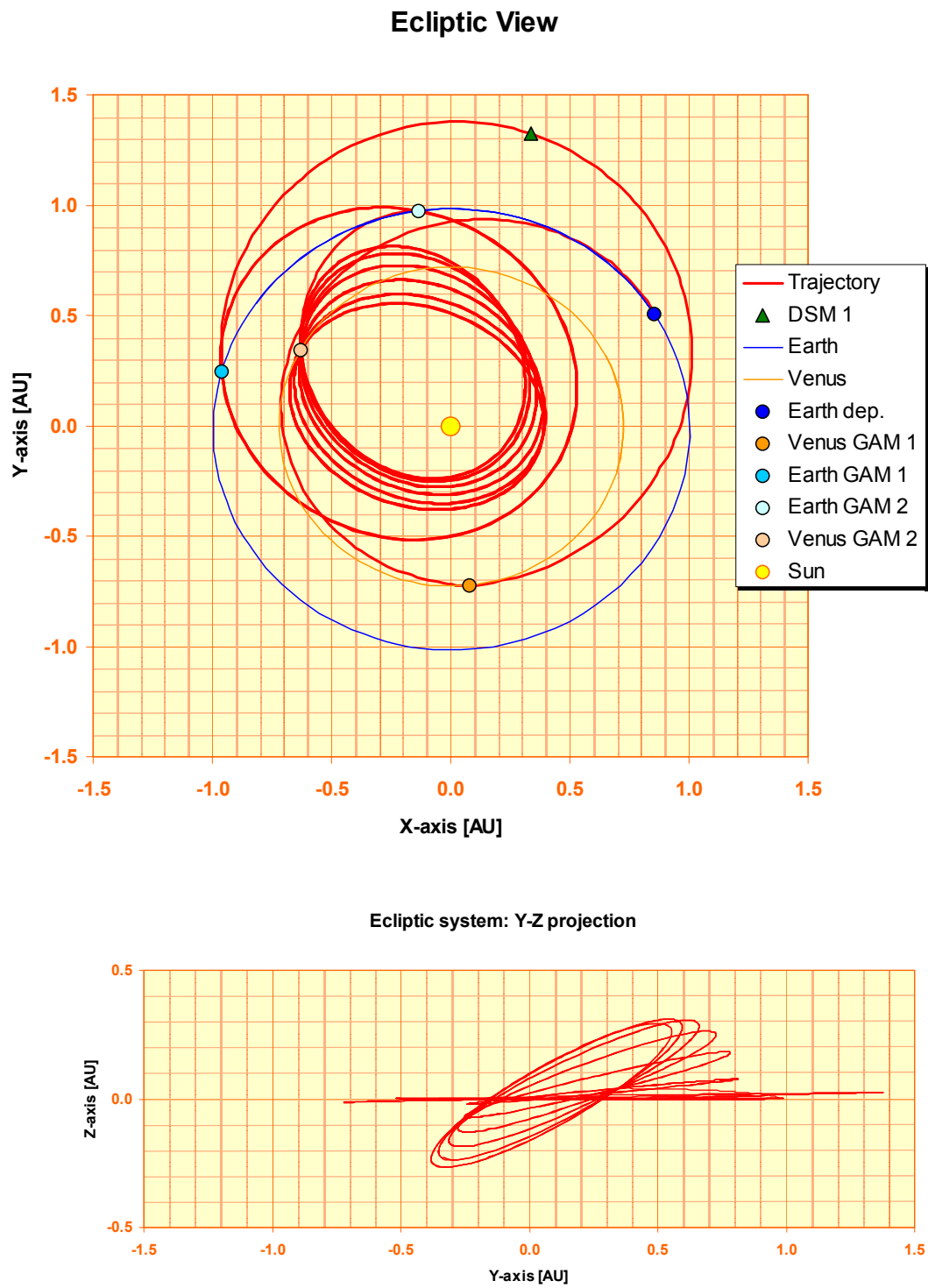

6.2 Ballistic transfer – 2015 launch

The second launch scenario to be investigated is May 2015, showing slightly more favourable delta-V conditions than the nominal trajectory. The key events of the scenario are provided in Table 6.2.1.

Table 6.2.1 – Summary of chemical profile (2015 launch).

	Date	Flight time		Event	Inclination [°]		Aphelion [AU]	Perihelion		
		Days	Years		Ecliptic	Sol. equ.		[AU]	[Sol. rad.]	
	2015-05-22	0	0	Launch	2.9	4.5	1.022	0.674	145	Transfer Phase
	2015-11-26	188	0.51	GAM V1	2.8	6.3	1.384	0.716	154	
	2016-05-28	372	1.02	DSM 1	2.8	6.3	1.384	0.708	152	
	2016-10-08	505	1.38	GAM E1	0.0	7.3	1.101	0.460	99	
	2018-08-08	1174	3.21	GAM E2	4.1	6.3	1.015	0.305	66	
	2018-10-09	1236	3.39	GAM V2	8.0	10.5	0.879	0.225	48	
Science Phase	2020-01-02	1686	4.62	GAM V3	17.4	20.0	0.852	0.252	54	Extended Mission
	2021-03-26	2135	5.85	GAM V4	24.7	27.3	0.809	0.295	63	
	2021-07-08	2239	6.13	ONM	24.7	27.3	0.809	0.295	63	
	2022-06-19	2585	7.08	GAM V5	29.4	31.9	0.762	0.342	74	
	2023-09-11	3034	8.31	GAM V6	31.5	34.0	0.729	0.375	81	
	2024-01-11	3156	8.64	EXM	31.5	34.0	0.729	0.375	81	
	2024-12-03	3483	9.54	GAM V7	31.6	34.2	0.726	0.378	81	
	2025-04-07	3608	9.88	EOM	31.6	34.2	0.726	0.378	81	

The differences wrt the 2013 profile are rather small: a) lower total delta-V (~400 m/s); b) faster inclination raise after GAM V2; c) slightly higher maximum heliospheric latitude of 34.2 deg (instead of 34.0).

The actual ballistic trajectory to be followed by the spacecraft is represented in figures 6.2.1 (projection on the ecliptic plane) and 6.2.2 (projection on the perpendicular plane). The ecliptic view shows the S/C trajectory in the inner Solar system during the cruise phase, from launch to the second Venus GAM. The impulsive Deep Space Manoeuvre (DSM) is indicated with a triangle. The Earth orbit is shown in blue. Venus' orbit is in yellow. The trajectory followed during the science phase is indicated in red. The Y-Z projection shows the evolution of the trajectory in a plane perpendicular to the ecliptic as to highlight the progressive inclination increase at each Venus GAM.

6.3 Ballistic transfer – 2017 launch

As a consequence of the possibility to have a nominal launch in May 2015, a third launch opportunity has been identified, namely early January 2017. The key events of the scenario are provided in Table 6.3.1 (page 19).

The differences wrt the 2015 profile are: a) lower delta-V (total ~300 m/s); b) longer transfer duration (4.1 yr, also due to the need for an extra revolution around the Sun to reach a 3:2 resonance); c) minimum perihelion distance of 0.23 AU; d) different evolution of increase of heliospheric latitude; e) larger maximum distance from Sun during cruise (~1.5 vs. ~1.4 AU). The actual ballistic trajectory to be followed by the spacecraft is represented in figures 6.3.1 (projection on the ecliptic plane, page 19).

Figure 6.2.1/2 Chemical trajectory (2015 - ecliptic view and Y-Z projection)

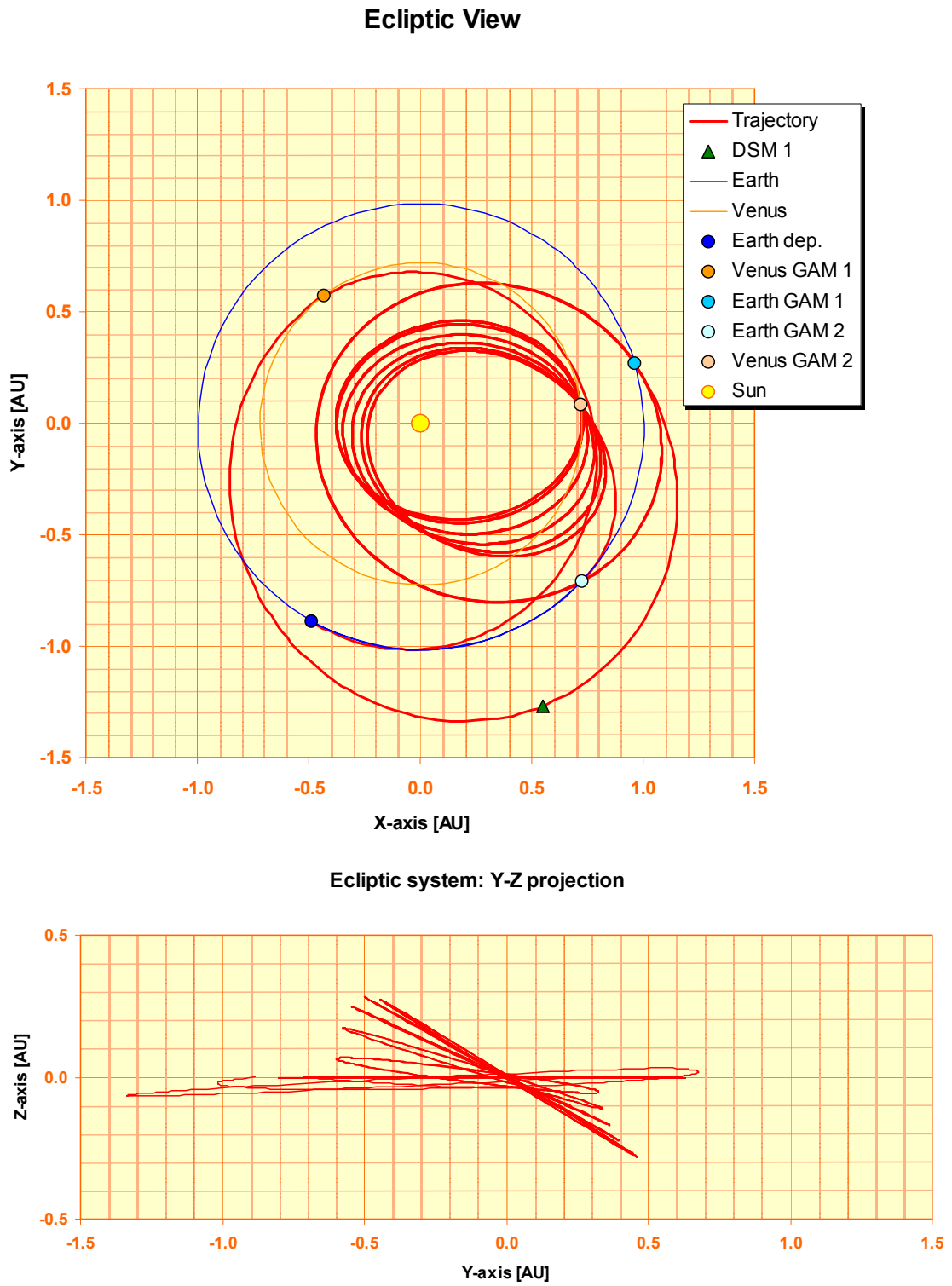
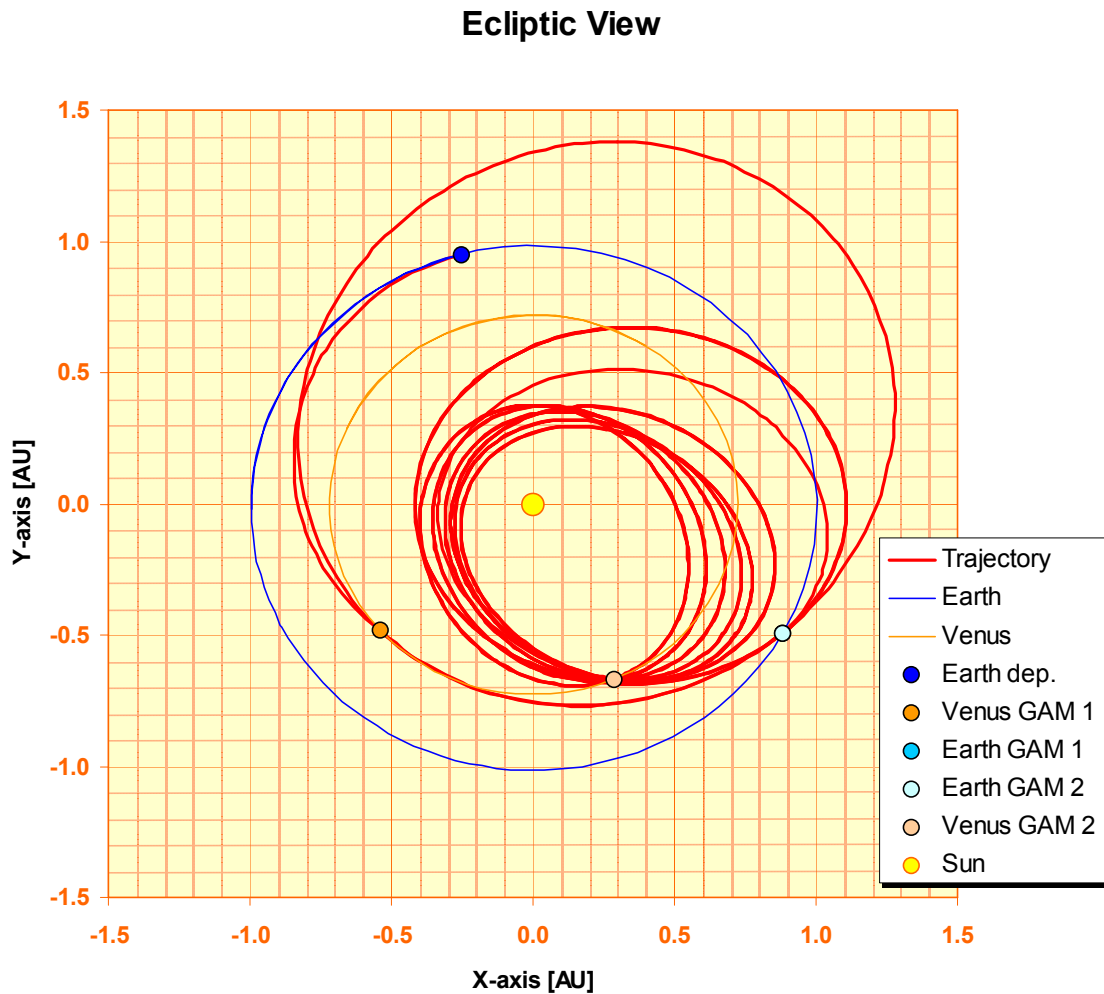

Table 6.3.1 – Summary of chemical profile (2017 launch).

Date	Flight time		Event	Inclination [°]		Aphelion [AU]	Perihelion	
	Days	Years		Ecliptic	Sol. equ.		[AU]	[Sol. rad.]
2017-01-05	0	0	Launch	2.2	5.5	0.983	0.660	142
2017-04-17	102	0.28	GAM V1	2.0	7.0	1.477	0.720	155
2018-08-24	596	1.63	GAM E1	2.2	7.0	1.110	0.417	90
2020-08-23	1327	3.63	GAM E2	3.3	8.7	1.054	0.331	71
2021-02-08	1495	4.09	GAM V2	10.0	15.8	0.919	0.275	59
2022-12-14	2169	5.94	GAM V3	8.3	14.0	0.874	0.230	49
2024-03-08	2619	7.17	GAM V4	17.5	23.3	0.843	0.261	56
2024-07-25	2758	7.55	ENM	17.5	23.3	0.843	0.261	56
2025-05-31	3068	8.40	GAM V5	24.3	30.1	0.798	0.306	66
2026-08-23	3518	9.63	GAM V6	28.4	34.2	0.753	0.351	76
2027-01-01	3649	9.99	EXM	28.4	34.2	0.753	0.351	76
2027-11-16	3967	10.86	GAM V7	29.9	35.7	0.728	0.376	81
2028-03-19	4091	11.20	EOM	29.9	35.7	0.728	0.376	81

Figure 6.3.1 Chemical trajectory (2017 - ecliptic view and Y-Z projection)



6.4 Note on residual System Level (Mass) Margins

During the assessment activities, great emphasis has been put on achieving adequate System Level Margins (i.e. SLM – requirement $\geq 20\%$). At the end of the delta study dedicated to the chemical profile, both contractors have showed a SLM compatible with the ESA requirement. Detailed comments on the SLM can be found in [RD-SDR]. We should stress here that the degree of definition reached by the Solar Orbiter assessment study is considerably higher than usual, due to the work done for BepiColombo and the previous main contract activities.

6.5 Consequences for Reference Payload

It is important to note that the payload complement described in section 4 applies to all profiles and launch opportunities examined during the study. In all cases a total maximum payload mass of 180 kg and a total average power of 180 W (including maturity margins) has been assumed to design the S/C. The only differences that should be highlighted are in the operations during cruise (instruments commissioning and calibration, taking several months, are not possible in the SEP profile, but possible with the chemical profile) and in the management of the mass system level margins (SLM); these issues are summarised in the table below.

SEP profile	Ballistic transfer
Composite prevents In-Situ P/L ops during cruise	In-Situ P/L operations are possible during cruise
Extensive SEP thrust arcs prevent operations of RS instruments during cruise	Preliminary RS ops and commissioning are possible during cruise
Tight mass SLM increases the risk associated with instruments development	More favourable mass SLM reduces the risk associated with instrument development
Shorter cruise (and total lifetime) reduces degradation/failure risks.	Longer cruise (and total lifetime) increases degradation / failure risks.
Faster science return (high lat - GAM V2 < 2 yr)	Later science return (high lat - GAM V2 > 3.3 yr)

6.6 Launcher

The launch vehicle (LV) and the launch site are common to all investigated profiles (Soyuz Fregat/ST 2–1B, launch from CSG). A few issues should be highlighted:

- LV is identical to that envisaged for BepiColombo, thus sharing development path and expected performance (~ 1500 kg at $c_3 \sim 10$ km²/s²).
- LV performance depends weakly upon the launch site (CSG / Baikonour) due to the escape trajectory (detailed investigations are expected from Starsem).
- A certain level of uncertainty exists on LV performance from CSG, due to a new ignition strategy for different stages and actual SF2-1B development / tests results.
- Starsem is presently offering only the fairing ST for launches from CSG.

6.7 Spacecraft design and industrial activities

The overall design philosophy is based on the adoption of a heat shield, maintaining the main body of the S/C in the shadow and thus allowing the use of conventional solutions. Continuous Sun-pointing is the key design driver, calling for specific measures in the design of the AOCS and of the FDIR approach. The spacecraft design for the ballistic transfer retains large commonality with the Orbiter Module designed for profile a), with an increased size (due to larger propellant tank/s) and a factor 2 larger solar arrays (due to larger distance from Sun

during cruise). The limited delta-V is compatible with a monopropellant system for all examined launch opportunities. Figures 6.6.1/2 below shows the spacecraft configurations identified by EADS-Astrium and Alcatel Alenia Space. ESA promoted the design of a single S/C design, possibly compatible with the different launch opportunities (with possible tank adjustments to reflect different delta-V). The contractors have confirmed the feasibility of this approach, characterised by inherent design flexibility and robustness to changes. Table 6.6.1/2 summarise the main design parameters at the end of the study (2013).

Assuming a successful development and qualification of the heat shield, industry has confirmed the feasibility of the thermal control system and its compliance with the instrument accommodation requirements.

Concerning electrical power generation and conditioning, the Solar Orbiter will benefit from the ongoing solar array developments for BepiColombo, with adaptations required by the higher flux, but also benefiting from the constant Sun pointing attitude.

Concerning telecommunications, the design baseline assumes the re-use of the HGA developed for BepiColombo, with operation limited to Sun distances > 0.3 AU. During the perihelion passes (i.e. when $0.22 < d < 0.3$ AU), the HGA would be kept in the shadow while data are recorded in the mass memory. Delta developments allowing the use of the antenna below 0.3 AU would be beneficial to the mission and the science (allowing higher operations safety, faster data analysis and related pointing correction manoeuvres) but not indispensable. Simultaneous X and Ka TM downlink is assumed.

It is thus confirmed that, albeit at the cost of a longer transfer, the chemical profile provides a lower complexity, risk and cost configuration, with the benefit of some science operations during cruise.

A key aspect of the industrial studies has been the re-use of functional elements from other ESA missions. The industrial activities have indeed confirmed the possibility to re-use a large number of units (not just from BepiColombo), so as to minimise the development costs. This effort has allowed shortening drastically the list of the Solar Orbiter TDA's [RD-TDP].

Details of the work done by the industrial teams are provided in the System Design Report [RD-SDR]. The key technical challenges are summarised in the table below:

Chemical transfer profile (CP)
Development and qualification of the heat shield, including instrument I/F (doors / baffles)
Orbiter solar arrays – design tailoring and thermal qualification
Autonomous, fail-proof Sun Pointing Keeping Mode, including SEU recovery under intense p^+ fluence
Development of the HTHGA (BepiColombo) and optimisation of the TM link budget
Overall thermal qualification at system level, in absence of a full scale, 22 Solar Constant test facility
Cleanliness approach, both at design level and during AIV/T activities

The main development drivers for the space segment are:

- Sun shield development and verification
- Overall qualification PA and approach, with particular regard to thermal testing.
- High Single Event Upset (SEU) rates / large p^+ fluences and related countermeasures.
- Demanding pointing stability required by the Remote Sensing instruments.
- Timely instrument development and management of related interfaces to platform.
- Need to meet launch date dictated by celestial mechanics (October 2013 – May 2015).
- Management of the system resources to maintain adequate margins and to avoid uncontrolled growth of P/L demands.
- Requirements deriving from operations, due to the number of Gravity Assist Manoeuvres and different space environment conditions.
- Cleanliness requirements (particulate/molecular as well as electro-magnetic).

- **Figure 6.6.1** – Chemical profile: spacecraft configuration from EADS-Astrium [RD-ASFP].

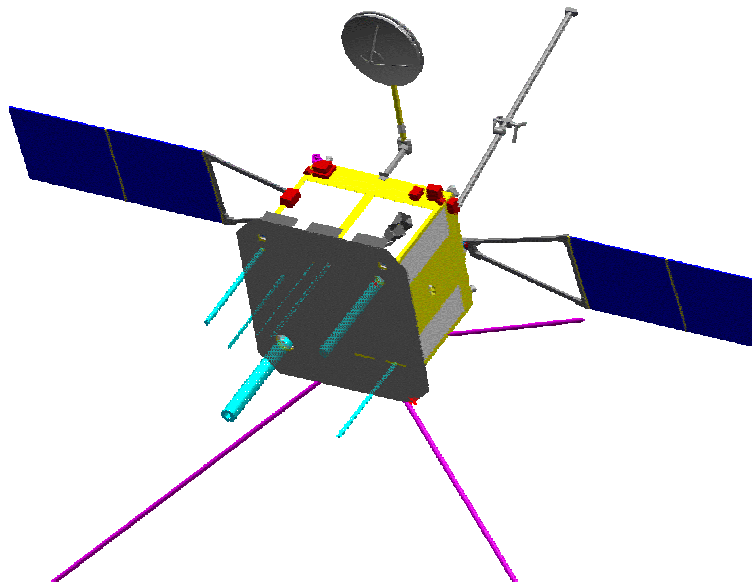

Table 6.6.1 Summary of key S/C parameters

Total dry separated mass	930 [kg]
Propellant mass (CP - monopropellant)	313 [kg]
Sizing case power [W]	700 [1.5AU], 825W [0.6 AU]
System Level Margin	> 20 %

- **Figure 6.6.2** – Chemical profile: spacecraft configuration from Alcatel Alenia Space [RD-AAFP].

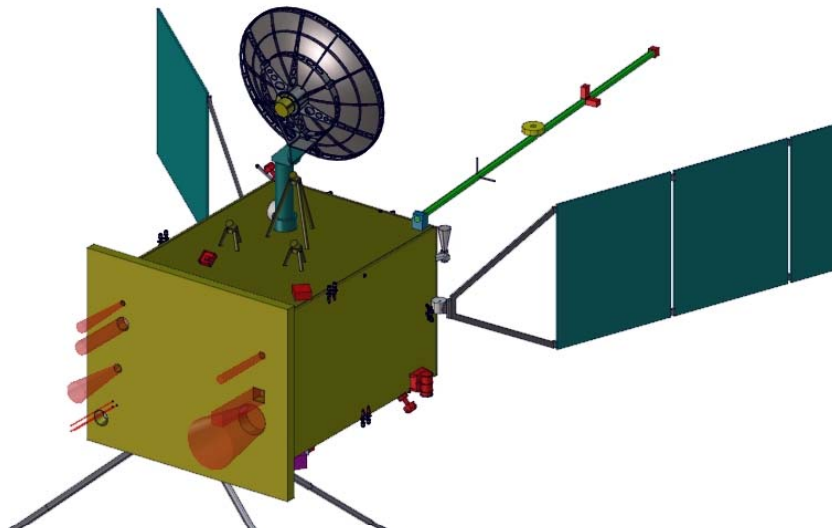

Table 6.6.2 Summary of key S/C parameters

Total dry separated mass (no margin)	860 [kg]
Propellant mass (CP)	309 [kg]
Sizing case power [W]	770 [1.5 AU], 720 [0.52 AU]
System Level Margin	> 20%

6.8 Ground segment

A summary of the issues and assumptions related to MOC infrastructure and activities are included in this section. Further details can be found in [RD-MOC] and in the related Study Assumptions Notes from ESOC.

- The MOC will be based at ESOC and utilise as much as possible commonalities with BepiColombo to minimise costs.
- The SOC will be at ESAC (tbc) and will utilise generic planning tools developed for planetary and solar-terrestrial missions.
- The PI teams will be responsible for the calibration of their instrument data, and the provision of fully calibrated, archival data sets, in line with the Science Management Plan [RD-SciMP].
- Operations will be pre-planned and tele-commands loaded to the spacecraft into a time tag buffer (e.g. autonomous operations and data storage during perihelion passes, when the High Gain Antenna cannot be deployed due to thermal constraints).
- New Norcia is the baseline ground station but, in case of a launch in 2013, there is a conflict during cruise phase, as it is also needed for Rosetta until end 2014.
- New Norcia requires upgrading for Ka band downlink (already planned by ESOC), which will operate in parallel to X band downlink to achieve a greater telemetry return.
- Cebreros to be considered for post BepiColombo operations, especially when visibility from New Norcia is poor, due to the increasing orbit inclination, to the benefit of a larger science return.

7 TECHNOLOGY DEVELOPMENTS

The technology developments required by the Solar Orbiter are summarised in the Technology Development Plan [RD-TDP]. The compilation of this document involved several steps: a) ESA evaluations (CDF exercise, March 2004); b) specific input from the contractors at the end of the system studies and delta activities; c) input from the science teams and previous work by the PLWG's on payload related matters; d) internal revision based on BC progress. Not very many TDAs are to be performed for the platform due to the re-use of BC units, while the situation for payload related TDAs is considered as more critical, both in technical and schedule terms.

7.1 Payload

The TDAs deemed necessary for the P/L development are summarised below. Considering their critical role for a timely delivery of the instruments it is recommended to begin activities as a matter of priority, as soon as the actual instruments have been selected and their design is confirmed. In specific cases it is possible to proceed before actual instrument selection. Additional details can be found in [RD-TDP].

TDA title	Remarks
Active Pixel Sensor for VIS & EUV applications	Important to all Remote Sensing units
Heat rejecting entrance window – VIM	Critical element due to I/F to heat shield (started).
Polarisation Modulation Package - VIM	Testing on radiation damage / qualification issues
Fabry-Perot filter - VIM instrument	Engineering model required to validate design
RPW antenna's (high temperature – stacer)	Important to develop expertise in Europe
Charge sensitive preamplifier – TOF ASIC	Required by a number of In-Situ sensor heads

7.2 Spacecraft

The TDA's deemed necessary for the platform development are summarised below. Given the commonality to BepiColombo, not many activities are needed. Specific attention is to be paid to the solar arrays of the Orbiter module and to the availability of an ESTEC based test facility capable of re-creating Solar Orbiter representative conditions. Additional details can be found in [RD-TDP]. The delta-activities have highlighted the need to give priority to the breadboarding and testing of the heat shield. Such an activity is closely related to the S/C design work (TCS) and it is recommended to include dedicated breadboard developments in the following industrial activities, as an integral part of the technical assistance phase.

TDA title	Remarks
Orbiter Solar Array	Critical – customisation of BepiColombo design to survive the ~20 SC flux
Heat Shield bread boarding	Critical – to be given priority and included in Technical Assistance Phase
Heat Shield Material Testing	Critical - Qualification of heat shield material in representative environment
High Temperature MLI	Delta development activities on BepiColombo HTMLI to match environment
SAS-AAD glasses / filters	Protective glasses / filters to be applied to existing SAS and AAD
Dedicated test facility	'1 m ³ class' test facility to create representative test environment
High Temperature HGA	Delta development to extend operations below 0.3 AU from the Sun

The chemical profile is compatible with the use of Off-The-Shelf equipment for the propulsion system, with considerable cost savings. Another area requiring for specific attention is the Solid State Mass Memory, also in relation to the final performance of the TM link. Given the rapid evolution of this sector, no major concerns are raised and, as a consequence, no specific TDA is proposed.

7.3 Link to the BepiColombo Technology Development Plan

A number of technology developments required by the Solar Orbiter are common to BepiColombo: this is in particular the case with the high temperature solar array and the development of the High Temperature HGA and related HT feeds and waveguides. The dependence on BepiColombo technologies has been examined critically, with a view to reduction in criticality so as to ensure a low risk for the Solar Orbiter development programme. The basic assumption made during the assessment study is that all TDAs carried out in the framework of BepiColombo and of relevance to Solar Orbiter, will be successful at the Solar Orbiter need date. The TDAs listed in 7.1 and 7.2 above are the remaining and complementary activities to be carried out for reducing further the Solar Orbiter development risk (see also section 12 for additional information on the link to BepiColombo).

8 INTERNATIONAL COOPERATION

The assumptions concerning potential contributions from international partners made during the assessment study are the following (in agreement with [RD-SciMP]):

- Full ESA mission (flight and ground segment)
- P/L contributions depending on heritage/expertise based on open AO

9 RISK ASSESSMENT

In the context of the Solar Orbiter assessment study, a dedicated Risk Assessment exercise has been conducted in collaboration with SCI-C. The exercise has taken into account also the results of the corresponding assessments performed by the two industrial teams. A summary of the results is provided below (all details can be found in [RD-RA]).

Fig. 9.1: Summary of the risk assessment result – CP profile and payload.

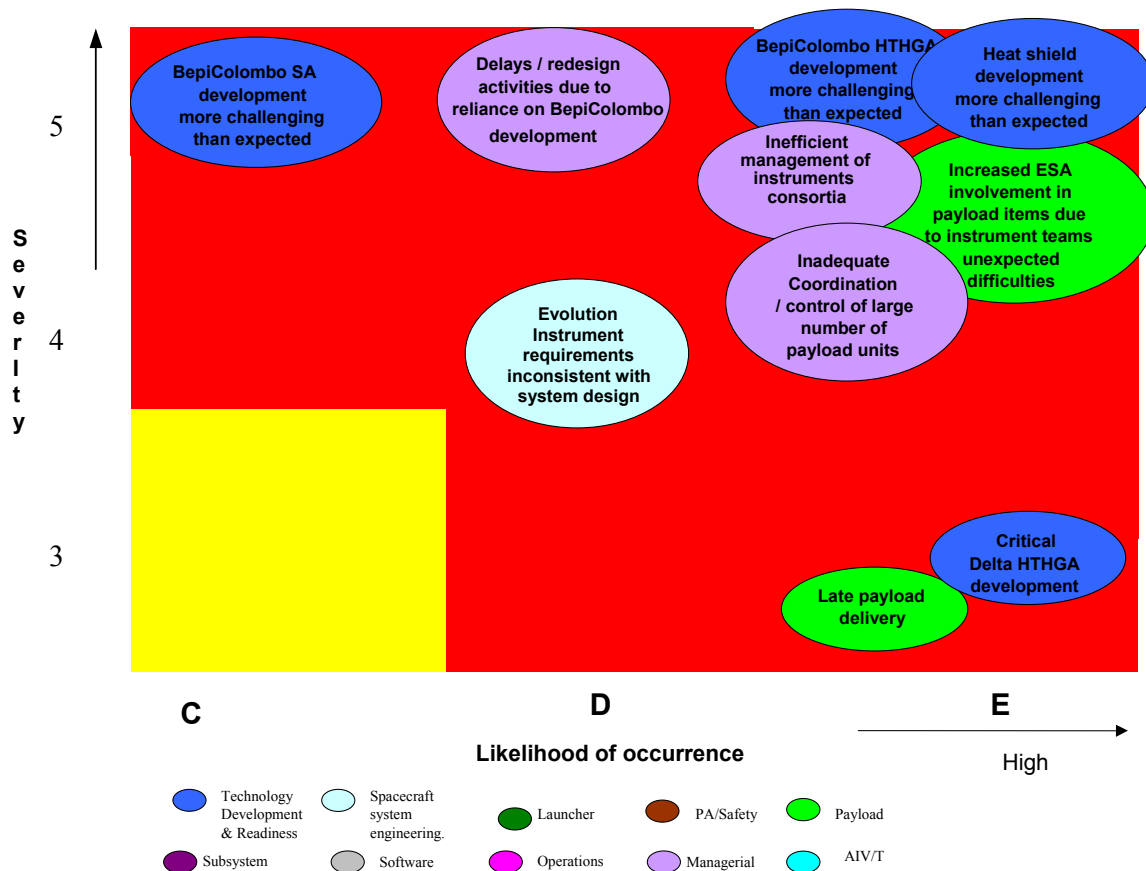

10 COST ASSESSMENT

A detailed cost assessment has been performed in order to estimate the CaC of the Solar Orbiter mission. Dedicated assessments have been produced by D-TEC in close cooperation with SCI-AM based on the documentation provided by both the industrial teams and then compared with the corresponding estimates provided directly from industry. A cost-risk analysis has also been applied. A preliminary estimate of the payload cost has also been carried out by both SCI-AM and D-TEC.

The estimates have demonstrated the compatibility of the mission with the budget of a medium size mission. All details and actual breakdown of the figures are provided in the Cost Assessment Report [RD-CA].

10.1 CaC and link to BepiColombo

The link to the BepiColombo mission has been retained during the delta-activities dedicated to the ballistic transfer, although the possibility to re-use existing elements from other missions has been introduced. The benefits induced on the Solar Orbiter by all preparatory activities performed in the frame of the mission to Mercury remain. Commonalities are significant, especially on avionics (including DHS, AOCS, TT&C), On-board Software and power system (e.g. solar arrays, PCDU). On this basis a relevant numbers of units could be common to both missions, allowing a cost mitigation.

The same arguments apply also to the ground segment, where similarities in the TT&C and the OBSW allow significant savings in terms of infrastructure, expertise and, to a certain extent, staff.

The actual level of savings and the opportunities resulting from a joint S/C procurement scheme are strongly depending on actual schedule considerations and on the synchronisation between the two projects. Based on the contractors input, under the assumption of a BepiColombo launch in the summer 2013 and a Solar Orbiter launch in May 2015, parallel procurement would be marginally applicable, while the agreement of procurement options on second units may be more realistic. Specific input in this direction has been passed to the BepiColombo project team, in view of the corresponding ITT preparation.

11 DEVELOPMENT SCHEDULE

The following sequence of events has been assumed for the near term future (End 2005 till June 2006):

1. Completion of assessment phase delta-activities by Q3-Q4 / 05.
2. ESA evaluations and information paper to SPC Nov 05
3. Final assessment report (delta report) to ESA executive by December 05.
4. Start of critical TDA's (e.g. selected P/L issues) before end of 2005.
5. Approval of Science Management Plan and SPC go ahead for instruments AO – May 06
6. Appointment of ESA project team by Q1 or Q2 / 06
7. Release of instruments AO by Q2/06.

In the case of the chemical profile and assuming a launch date in May 2015, the following milestones have been identified:

- Technical assistance phase (1.5 yr, Q2/06 – Q4/07)
- Definition phase (1.5 yr, Q4/07 – Q2/09)

- Implementation phase (~5 yr, Q1/10 – Q2/15, including 6 month contingency)

Based on the milestones listed above, the schedule of figure 11.1 below is assumed as reference for further elaboration. Under the assumption of releasing the instruments AO in Q2/2006, the plan appears as realistic with adequate (but not superfluous) margins. It should be noted that, while from a technical point of view a launch in 2013 appears feasible, the 2015 launch opportunity corresponds to a more favourable trajectory and to a lower development risk, including both spacecraft and instruments, and it is therefore recommended.

Figure 11.1: Reference Solar Orbiter schedule (nominal launch date).

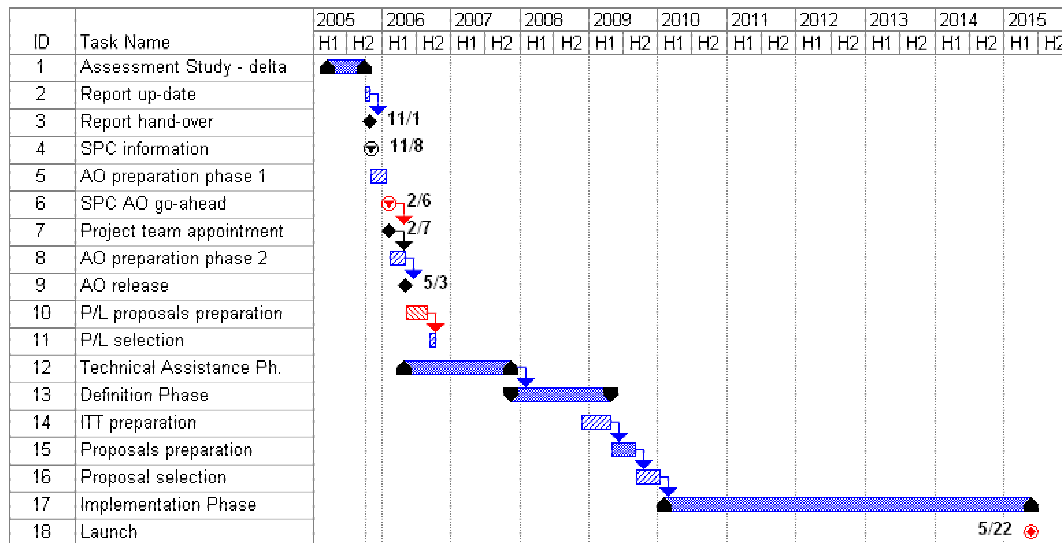

Assuming a nominal launch in 2015, the back-up launch opportunity would correspond to January 2017, described in section 6.

When discussing the Solar Orbiter development schedule and selecting the launch date, two main issues are to be considered (in addition to any programmatic constraints):

- 1) The Venus launch window driving the mission delta-V requirement and the cruise duration, with a synodic period of about 19 month;
- 2) The solar cycle (predicted maxima in 2010 and then in 2021). From a scientific point of view, an ideal phasing of the mission with respect to the solar cycle would be such that the polar regions of the Sun are viewed from the highest achievable latitudes when well-developed coronal holes are present, i.e. near solar minimum. Similarly, many of the near-Sun studies would benefit from a relatively active Sun. On this basis the 2015 launch opportunity is better than the 2013 (ballistic transfer). Nevertheless, it should be stressed that first-class science will be achieved by the Solar Orbiter independent of the exact point in the solar activity cycle at which these mission phases occur.

The current situation is illustrated in figure 11.2, including all different launch opportunities 2013, 2015 and 2017. The second Venus GAM marks the end of the transfer phase and the beginning of the inclination-raising phase, while GAM V4 corresponds to the completion of the nominal mission. The extended mission

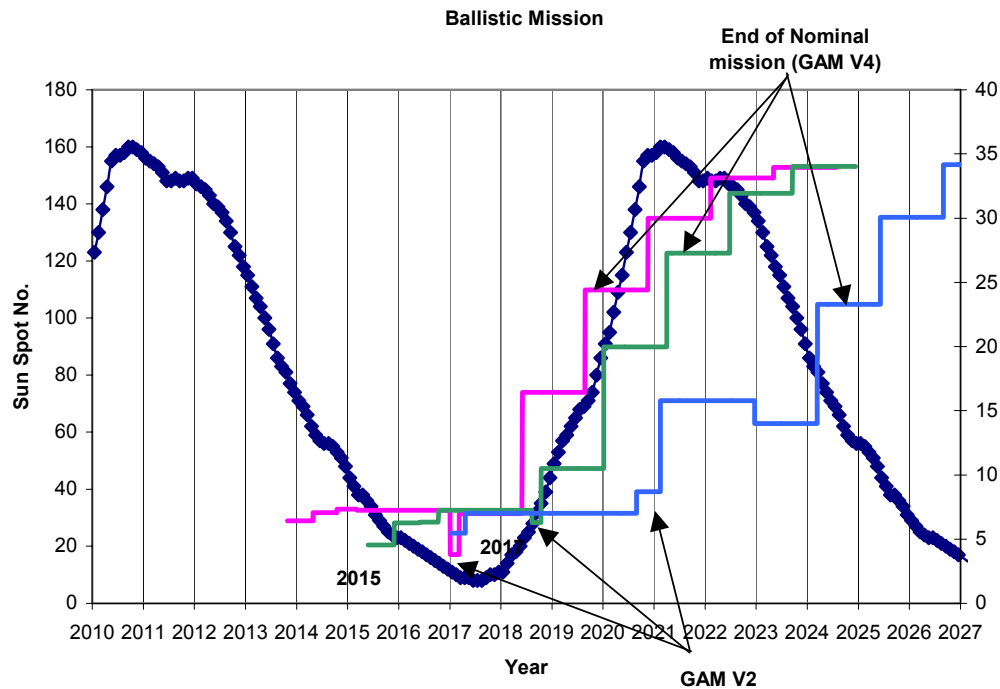
Figure 11.2: Solar Orbiter mission (with different launch dates) and solar cycle.

12 LINK TO BEPICOLOMBO

The chemical profile allows reducing the dependence of Solar Orbiter on the most critical technologies (propulsion and related power conditioning). Nevertheless both industrial contractors have re-confirmed the link between BepiColombo and Solar Orbiter, identifying a list of recurring or modified units. The list is summarised in table 12.1 below for the ballistic transfer scenario (Chemical Propulsion – single C/OM).

It is important to stress that from a programmatic point of view, recurring (or partially recurring) avionics (including TT&C) and large commonality of the DHS / OBSW, as proved by the recent Rosetta-MEX-VEX experience, play a critical role also with respect to the ground segment infrastructure and staffing level (MOC). On this basis, priority should be given to commonalities in such areas.

Specific input on these matters has been passed to the BepiColombo project team in preparation of the corresponding Invitation To Tender for the project implementation phase.

A certain degree of schedule staggering between the two projects is also considered as beneficial in order to reduce the propagation of possible delays and technical problems.

Matters related to industrial policy are not discussed in this report, but clearly different prime responsibility levels can be envisaged depending on the actual mission profile choice.

Table 12.1 – Solar Orbiter / BepiColombo commonality (Chemical Profile)

Module	Subsystem	Unit / technology	Heritage & remarks
Orbiter OM	Structure	Primary – secondary Adapters	Solar Orbiter specific Solar Orbiter specific
	Thermal Control	MLI Heat pipes Radiators Heat shield	BepiColombo modified BepiColombo modified (customised - tbc) Solar Orbiter specific Solar Orbiter specific
	Power	Solar Array PCDU Battery SADM Hold-down / release / pyro	BepiColombo modified (major) BepiColombo re-use / customised BepiColombo re-use / customised Off The Shelf – other than BepiColombo BepiColombo re-use (as is)
	DHS	DMU SSMM OSW	BepiColombo re-use / customised BepiColombo customised BepiColombo modified
	AOCS	Sun sensors STR IMU RW's	BepiColombo modified BepiColombo as is Off The Shelf – other than BepiColombo Off The Shelf – other than BepiColombo
	TT&C	HTHGA HGA pointing mechanism X band LGA/MGA X/X-Ka transponder X & Ka TWTA EPC RFDU Harness / switch / WG / etc	BepiColombo as is BepiColombo (re-positioned) BepiColombo as is (or other OTS) BepiColombo modified BepiColombo as is BepiColombo as is BepiColombo modified BepiColombo as is / modified (minor)
	Propulsion	Hydrazine tank Piping / tubing Thrusters	Off The Shelf – other than BepiColombo Off The Shelf – other than BepiColombo Off The Shelf – other than BepiColombo

13 CONCLUSIONS

The assessment study of the Solar Orbiter has addressed all mission areas, from the scientific requirements to the payload complement, the space and ground segments, and the respective technology readiness, including all corresponding programmatic aspects.

Specific attention has been given to the reference payload, in the form of a dedicated industrial study as well as of internal activities, in order to prepare adequately for the future AO and maintain a certain degree of control over the corresponding spacecraft resources. These activities have indicated that, given the number and complexity of the instruments on board, such an attention should be also given in the following mission phases. The system level study has indicated that two mission profiles are viable and compatible with the science requirements:

- a) Solar Electric Propulsion and a 1.8-year cruise phase (higher development risk/cost);
- b) Chemical Propulsion, with a 3.4-year cruise phase (lower development risk/cost).

In both cases, all critical design drivers have been analysed and, while design challenges do exist, no major feasibility questions have been raised, showing a feasible mission, technically compatible even with the launch date of October 2013. On the basis of both programmatic and technical reasons, a launch in May 2015 is baselined.

The industrial study has also confirmed the relevance of the BepiColombo link and of the related TDAs, showing that a very limited number of Solar Orbiter specific TDAs are required. The programmatic analysis has indicated that, under the assumption of a tight resource management and a 'no-nice-to-have' approach, the Solar Orbiter mission is compatible with the original budget allocation.

14 RECOMMENDATIONS

Based on the work performed in the context of the assessment study, the Science Payload & Advanced Concepts Office, Science Missions sections (SCI-AM) makes the following recommendations:

- To select the chemical profile for the forthcoming definition phase on the basis of its full compliance with the science requirements, the additional possibility to perform science during transfer and the lower development risks and cost.
- To consider Solar Orbiter as a mature mission, ready for entering the Definition Phase.
- Although the mission is technically compatible with a launch date in Q4/2013, the May 2015 launch opportunity is recommended as it has a more attractive trajectory and provides additional margins that are useful to reduce further the development risk of both S/C and P/L.
- To enable the approval process leading to the release of the payload AO in Q2 / 2006, as to maintain adequate schedule margins.
- To make planning provisions so as to ensure a launch in 2015, thus minimising the probability to use the 2017 back-up launch date, due to its longer transfer phase.
- To start the highest priority TDAs as early as possible, especially on payload and Sun shield issues.
- To include the development of a heat shield breadboard already from the start of the technical assistance phase.
- To monitor with attention the evolution of the instruments selection, enforcing the hierarchical relation between Science Requirements, reference payload and accepted instrument proposals.