

ESA-SRE(2008)2

12 February 2009

# **JUPITER GANYMEDE ORBITER**

ESA Contribution to the  
Europa Jupiter System Mission



Assessment Study Report

## **FRONT COVER**

Artistic impression of the Jupiter Ganymede Orbiter, Jupiter, and the Galilean moons with a statue of Pierre Simon de Laplace in the foreground.

## Study Team

### ESA Study Team

Member	Affiliation	Expertise
Anamarija Stankov - Study Manager	European Space Agency	Project Management and Systems Engineering
Jean-Pierre Lebreton - Study Scientist	European Space Agency	Plasma Physics
Arno Wielders - Study Payload Manager	European Space Agency	Project Management
Mark Baldesarra	European Space Agency	System Engineering Support
Robin Biesbroek - Concurrent Design Facility Study Lead	European Space Agency	System Engineering, Mission Analysis
Concurrent Design Facility Team	European Space Agency	System Engineering, S/C Subsystems, Cost, Risk
Andrew Caldwell	European Space Agency	System Engineering Support
Peter Falkner	European Space Agency	Project Management and Systems Engineering

### NASA Study Team

Member	Affiliation	Expertise
Curt Niebur – Program Scientist	NASA Headquarters	Program Science
Len Dudzinski – Program Executive	NASA Headquarters	Program Management
Jim Cutts – Program Management	Jet Propulsion Laboratory	Program Management, Technology
Karla Clark— Study Lead	Jet Propulsion Laboratory	Project Management and Systems Engineering
Tom Magner	John Hopkins University - Applied Physics Lab	Project Management
Ed Blazejewski	Jet Propulsion Laboratory	Sensors and Detectors
John Boldt	John Hopkins University - Applied Physics Lab	Payload Engineering
Paul Bowerman	Jet Propulsion Laboratory	Circuit Reliability
Taher Daud	Jet Propulsion Laboratory	Avionics
Ken Donahue - Student	Jet Propulsion Laboratory – Massachusetts Institute of Technology	Systems Engineering
Mohamed Elghefari	Jet Propulsion Laboratory	Cost
Nayla Fernandez	Jet Propulsion Laboratory	Electronic Parts
Sarah Ferraro - Student	Jet Propulsion Laboratory – Harvey Mudd College	System Engineering
Henry Garrett	Jet Propulsion Laboratory	Jupiter Environments
Paula Grunthaner	Jet Propulsion Laboratory	Instrument Workshop, Sensors and Detectors
Ken Hibbard	John Hopkins University - Applied Physics Lab	Systems Engineering
Mark Holdridge	John Hopkins University - Applied Physics Lab	Operations
Allan Johnston	Jet Propulsion Laboratory	Electronic Parts
Ed Jorgenson	Jet Propulsion Laboratory	Cost
Insoo Jun	Jet Propulsion Laboratory	Radiation Environments and Shielding
Richard Key	Jet Propulsion Laboratory	Report Generation
James Kinnison	John Hopkins University - Applied Physics Lab	Systems Engineering - Risk Assessment

Member	Affiliation	Expertise
Ken Klaasen	Jet Propulsion Laboratory	Instruments
Kevin Kloster - Student	Jet Propulsion Laboratory – Purdue University	Trajectory Design
Rob Lock	Jet Propulsion Laboratory	Mission Planning and Operational Scenarios
Jan Ludwinski	Jet Propulsion Laboratory	Mission Design
Steve McClure	Jet Propulsion Laboratory	Electronic Parts
Anastassious Petropoulos	Jet Propulsion Laboratory	Trajectory Design
Bob Rasmussen	Jet Propulsion Laboratory	Systems Engineering
Ed Reynolds	John Hopkins University - Applied Physics Lab	Project Management
David Roth	John Hopkins University - Applied Physics Lab	Radiation Effects
Eddy Shalom	Jet Propulsion Laboratory	Avionics
Doug Sheldon	Jet Propulsion Laboratory	ASICs and FPGAs
Andy Spry	Jet Propulsion Laboratory	Planetary Protection
Karl Strauss	Jet Propulsion Laboratory	Solid State Memory
Grace Tan-Wang	Jet Propulsion Laboratory	Systems Engineering
Steve Thibault	John Hopkins University - Applied Physics Lab	Integration and Test
Violet Tissot	Jet Propulsion Laboratory	Schedules
Tracy Van Houten	Jet Propulsion Laboratory	Systems Engineering
Greg Welz	Jet Propulsion Laboratory	Operations
Lawrence Wilfarth	John Hopkins University - Applied Physics Lab	Cost
Tsun-Yee Yan	Jet Propulsion Laboratory	Radiation effort management and System Model

### Joint Science Definition Team

	Affiliation	Expertise
<b>EU JSDT Membership</b>		
Jean-Pierre Lebreton - Co-Chair - Study Scientist	European Space Agency	Plasma Physics
Michel Blanc - Lead Scientist	École Polytechnique	Magnetospheres
Lorenzo Bruzzone	University of Trento	Radar/Geophysics
Michele Dougherty	Imperial College	Fields & Particles
Pierre Drossart	Paris Observatory	Jupiter
Olivier Grasset	University of Nantes	Geology
Hauke Hußman	German Aerospace Centre (DLR)	Geophysics
Norbert Krupp	Max Planck Institute	Fields & Particles
Ingo Mueller-Wodarg	Imperial College	Fields & Particles
Olga Prieto-Ballasteros	INTA	Astrobiology
Daniel Prieur	University of Bretagne Occidentale	Astrobiology
Frank Sohl	German Aerospace Centre (DLR)	Geophysics
Paolo Tortora	University of Bologna	Radio Science
Federico Tosi	Institute of Physics of Interplanetary Space	Origins
Peter Wurz	University of Bern	Origins
<b>US JSDT Membership</b>		
Ron Greeley - Co-Chair	Arizona State University	Europa

Bob Pappalardo	Jet Propulsion Laboratory	Europa and Jupiter System
Ariel Anbar	Arizona State University	Astrobiology
Bruce Bills	Goddard Space Flight Center / University of California San Diego	Geophysics
Diana Blaney	Jet Propulsion Laboratory	Composition
Don Blankenship	University of Texas	Radar/Geophysics
Phil Christensen	Arizona State University	Composition
Brad Dalton	Jet Propulsion Laboratory	Composition
Jody Deming	University of Washington	Astrobiology
Leigh Fletcher	Jet Propulsion Laboratory	Jupiter Atmosphere
Rick Greenberg	University of Arizona	Geophysics
Kevin Hand	Jet Propulsion Laboratory	Astrobiology
Amanda Hendrix	Jet Propulsion Laboratory	Satellites
Krishan Khurana	University of California Los Angeles	Fields & Particles
Tom McCord	Bear Fight Center	Composition
Melissa McGrath	Marshall Space Flight Center	Satellites
Bill Moore	University of California Los Angeles	Geophysics
Jeff Moore	Ames Research Center	Geology
Francis Nimmo	University of California Santa Cruz	Geophysics
Chris Paranicas	John Hopkins University - Applied Physics Lab	Fields & Particles
Louise Prockter	John Hopkins University - Applied Physics Lab	Geology
Jerry Schubert	University of California Los Angeles	Jupiter
David Senske	Jet Propulsion Laboratory	Satellites
Adam Showman	University of Arizona	Jupiter
Mark Showalter	SETI Institute	Rings
Mitch Sogin	Marine Biological Laboratory	Astrobiology
John Spencer	South West Research Institute	Satellites
Hunter Waite	South West Research Institute	Fields & Particles
<b>Japan JSDT Membership</b>		
Masaki Fujimoto	Institute of Space and Astronautical Science / Japan Space Exploration Agency	Fields & Particles
Takeshi Takashima	Institute of Space and Astronautical Science / Japan Space Exploration Agency	Fields & Particles
Sho Sasaki	National Astronomical Observatory of Japan	Satellites
Yasumasa Kasaba	Tohoku University	Fields & Particles
Yukihiro Takahashi	Tohoku University	Jupiter

**TABLE 1: JUPITER GANYMEDE ORBITER SUMMARY (STATUS NOVEMBER 2008) .**

<b>Scientific objectives:</b>					
JGO would be the ESA element of the two-spacecraft mission EJSM that includes also the Jupiter Europa Orbiter (JEO) that would be provided by NASA. The EJSM overarching theme is the study of emergence of habitable worlds around gas giants. JGO will perform an in-depth exploration of the pair Ganymede-Callisto and focus on Ganymede, one of the two ocean-bearing Galilean satellites. JGO will also perform Jupiter System observations with emphasis on two key coupling processes: gravitational coupling and electro-dynamic interactions.					
<b>Model payload:</b>					
CAMERA PACKAGE (WAC+MRC)		TIR MAPPER (TM)			
RADIO SCIENCE PACKAGE (JRST + USO)		SUB-MM WAVE SOUNDER (SWI)			
MAGNETOMETERS (MAG)		MICRO LASER ALTIMETER (MLA)			
V/NIR IMAGING SPECTROMETER (VIRHIS)		UV IMAGING SPECTROMETER (UVIS)			
PLASMA PACKAGE (PLP)		RADAR (SSR)			
<b>Interplanetary cruise:</b>					
Ariane 5 ECA launch from Kourou					
<b>Launch date 11 March 2020</b>					
Cruise duration 5.9 years					
<b>Operational orbits:</b>					
Jupiter	Jupiter/Callisto	Ganymede ellipt.	Ganymede circ.		
13 x 245 R <sub>J</sub> injection	resonant orbit	200x6000km	200km		
<b>Mission lifetime:</b>					
					Total
5.9 years transfer time	383 days orbit	80 days	180 days	3254d, ~8.9y	
<b>Spacecraft details</b>					
Stabilisation	3-axis				
Orientation	Nadir, except during communication periods				
Mass	Mass figures include 5-20% component margin (depending on maturity) and 20% system margin.				
	Model payload (kg)	67 kg P/L, launch 2018		73 kg P/L, launch 2020	
	<b>Dry (kg) (incl. margin)</b>	1264 kg		1275 kg	
	<b>Wet (kg) (incl. margin)</b>	3516 kg (incl. launch adapter)		3493 kg (incl. launch adapter)	
Radiation	85 krad (8mm Al shielding), current shielding mass estimate ~80 kg				
Power (incl. margins)	539 W (EOL), 51m <sup>2</sup> solar panels				
TM band	X-band (additional Ka-band for radio science experiment)				
Antenna	HGA, MGA, 2 LGA				
Data storage	256 Gbit				
P/L power	207 W (total sum for all instruments)				
Dimensions	Stowed	width: 3.1 m, depth: 2.68 m, HGA diameter: 2.8 m. height from launch interface: 3.99 m			
	Deployed	SA span: 32.86 m; depth span with booms: 7.77 m; total height: 4.64 m			
<b>Challenges:</b>					
Radiation: Radiation dose hardened systems (order of 100 krad)					
Efficient high radiation compatible, low intensity, low temperature solar power generators, no concentrators					
Thermal: Hot and cold case drivers (Venus fly-by and Jovian system respectively)					
Low resource: Both P/L and S/C subsystems (including comms) must have low resource requirements.					
Communications: high data rate X-&Ka-band transponders					
Autonomy: Autonomous S/C during entire mission as well as for commissioning and ops around Ganymede					
Planetary protection: JGO needs to be integrated while meeting the appropriate planetary protection requirements					

## **TABLE OF CONTENTS**

<b>1</b>	<b>INTRODUCTION</b>	<b>10</b>
1.1	Purpose of this document	10
1.2	The Jupiter Ganymede Orbiter: Executive Summary	10
<b>2</b>	<b>JUPITER GANYMEDE ORBITER SCIENCE BACKGROUND</b>	<b>13</b>
2.1	Introduction	13
2.2	Science Goals and context of the EJSM mission	13
2.2.1	Overarching Theme of the EJSM mission .....	13
2.2.2	Science goals of EJSM.....	14
2.2.3	Relevance to Cosmic Vision Themes.....	19
2.2.4	Observation strategy for EJSM.....	20
2.3	Science goals of JGO	22
2.3.1	Ganymede.....	22
2.3.2	The Satellite system .....	24
2.3.2.1	Callisto.....	24
2.3.2.2	Io and Europa .....	26
2.3.3	Jupiter as a planet .....	28
2.3.3.1	The upper atmosphere .....	28
2.3.3.2	The stratosphere .....	29
2.3.3.3	The troposphere .....	29
2.3.4	Magnetosphere of Jupiter.....	30
2.3.4.1	The magnetosphere as a fast magnetic rotator.....	30
2.3.4.2	The magnetosphere as a giant accelerator .....	31
2.3.5	Jupiter system .....	32
2.3.5.1	Satellite/magnetosphere interactions: the magnetosphere as a magnetized binary system	32
2.4	Science implementation and measurement requirements for JGO	33
2.4.1	Ganymede.....	33
2.4.2	Satellite system .....	36
2.4.2.1	Callisto.....	36
2.4.2.2	Other satellites.....	37
2.4.3	Jupiter.....	39
2.4.4	Magnetosphere.....	40
2.5	JGO model payload	41
2.5.1	Introduction.....	41
2.5.2	Model payload composition .....	41
2.5.3	Instrument Description.....	43
2.5.3.1	Camera package .....	43
2.5.3.2	VIRHIS - Visible and Infrared Hyperspectral Imaging Spectrometer .....	43
2.5.3.3	Thermal Infrared Mapper .....	44
2.5.3.4	UV spectrometer.....	44
2.5.3.5	Micro Laser Altimeter.....	44
2.5.3.6	Sub-surface Radar .....	44
2.5.3.7	Sub-millimetre Wave Sounder .....	45
2.5.3.8	Plasma Package.....	45
2.5.3.9	Magnetometer .....	46

2.5.3.10 Radio Science Package .....	46
2.5.4 CDF payload composition .....	46
2.6 Traceability matrix for the Jupiter Ganymede Orbiter (JGO): from scientific objectives to measurement requirements .....	48
2.7 Synergies with JEO .....	54
2.8 Additional Payload and Science that will be gained .....	55
2.8.1 Ganymede and Callisto .....	57
2.8.2 Jupiter's internal structure .....	57
2.8.3 Magnetosphere and aurora .....	57
2.8.4 Dust .....	58
2.8.5 Jupiter's atmosphere .....	58
2.8.6 Science that will be gained .....	58
<b>3 MISSION PROFILE</b> .....	<b>62</b>
3.1 Mission Architecture .....	62
3.2 Key Challenges and mission driver .....	62
3.3 Performed Major Mission Profile Trades .....	63
3.3.1 Launcher .....	64
3.3.2 Model payload .....	64
3.3.3 Staging .....	65
3.3.4 Transfer Options .....	65
3.3.5 Combined Launch .....	66
3.3.6 Summary on the Major CDF Trade Results .....	66
3.4 Mission Environment .....	66
3.4.1 Radiation models overview .....	67
3.4.2 Total dose calculation .....	68
3.4.3 Shielding mass analysis .....	70
3.4.4 Refinement of radiation model at Ganymede .....	70
3.5 Planetary protection .....	71
<b>4 MISSION ANALYSIS</b> .....	<b>73</b>
4.1 Introduction .....	73
4.2 Mission Phases .....	73
4.2.1 Launch .....	74
4.2.2 The interplanetary cruise phase .....	74
4.2.3 Jupiter orbit insertion and planetocentric phase .....	74
4.2.4 Callisto Science Phase .....	75
4.2.5 Ganymede approach and orbit .....	75
4.2.5.1 Elliptical orbit .....	76
4.2.5.2 Circular orbit .....	76
4.2.6 Mission Analysis Trade-offs .....	76
4.3 Ground Segment .....	77
4.4 End of mission options .....	77
4.5 Change of launch date to 2020 and P/L complement .....	77
<b>5 THE SPACE SEGMENT</b> .....	<b>80</b>
5.1 Requirements .....	80
5.2 Baseline Design .....	80
5.2.1 Structures and Configuration .....	80
5.2.2 Power .....	84
5.2.2.1 Solar Arrays .....	84
5.2.2.2 Solar cell degradation .....	85
5.2.2.3 Batteries .....	86



---

5.2.3	Thermal Control.....	86
5.2.4	Propulsion.....	87
5.2.5	Attitude and Orbit Control Subsystem (AOCS).....	90
5.2.5.1	Solar Array Steering Analysis.....	90
5.2.6	Mechanisms .....	91
5.2.7	Telecommunication .....	92
5.2.7.1	Baseline design .....	92
5.2.8	Data handling .....	93
<b>6</b>	<b>PROGRAMMATICS</b>	<b>95</b>
6.1	Schedule	95
6.2	Management Approach	95
6.3	Estimated Mission Cost	96
<b>7</b>	<b>DEVELOPMENT PLAN</b>	<b>97</b>
7.1	Technology for payload	97
7.2	Running Technology Development Activities	97
7.2.1	Testing of Low Intensity Low Temperature Solar cells in representative environment	97
7.2.2	Jupiter Radiation Modelling .....	97
7.2.3	Mechanical deployment of radar antenna .....	98
7.3	Technology needs and technology plan	98
7.4	Major Open Issues or Trades	98
<b>8</b>	<b>ANNEX</b>	<b>100</b>
8.1	List of Abbreviations	100
8.2	COSPAR Planetary Protection Policy	102
8.3	Technology readiness levels	102
8.4	References	103

## 1 INTRODUCTION

### 1.1 Purpose of this document

This document gives a concise overview of the ESA assessment study based on the "Laplace" proposal [RD 02] for the Cosmic Vision 2015-2025 [RD 01] call. It describes the work performed during the assessment study, which includes the Concurrent Design Facility (CDF) study and subsequent scientific and engineering work. The aim of this study was to quickly assess the technical feasibility, cost and schedule in the framework of a Cosmic Vision 2015-2025 L-class mission (see <http://sci.esa.int/science-e/www/area/index.cfm?fareaid=100>) and to prepare the follow-on industrial studies. The transition from the submitted "Laplace" proposal to the ESA/NASA/JAXA joint mission called "Europa/Jupiter System Mission" (EJSM) is documented and the baseline of the ESA contribution to this mission, the Jupiter Ganymede Orbiter (JGO), is described in detail.

The presented configuration and budgets reflect the status as of October 2008. More details on this study can be found in the final CDF report [RD 03].

The scientific model payload described in this report, and in greater detail in the Payload Definition Document [RD 17], is based on the Science Requirements Document [RD 16] and inputs received from the Joined Study Science Definition Team. The instrument descriptions utilized are to show proof of concept only and should not be taken to be the final set of instruments nor final implementations. Alternative instrument concepts and techniques may be selected via the NASA/ESA coordinated Announcement of Opportunity process to meet the mission objectives.

### 1.2 The Jupiter Ganymede Orbiter: Executive Summary

The Jupiter system is not only regarded as an object of outstanding interest in itself, but also as a template for a better understanding of giant planets systems in general, which are now known to be present not only in the Solar System, but also around other nearby stars. By studying the Jupiter system, and unravelling the history of the evolution of that system from initial formation to the possible emergence of habitats and life, this mission will also shed new light on the potential for the emergence of life in our galactic neighbourhood and beyond.

The merging of ESA's Cosmic Vision Laplace proposal and NASA's two Outer Planets Flagship mission studies, "Europa Orbiter" and "Jupiter System Observer" led to the joint "Europa Jupiter System Mission" (EJSM) study. This is an international mission proposed to be developed in collaboration between NASA, ESA and possibly JAXA. The reference mission architecture consists of the following elements:

- A Jupiter Ganymede Orbiter (JGO), assumed to be developed and launched by ESA.
- A Jupiter Europa Orbiter (JEO), assumed to be developed and launched by NASA.

A Jupiter Magnetospheric Orbiter (JMO) will possibly be developed and launched by JAXA, but is not part of the current baseline of the EJSM mission.

EJSM will study Jupiter and its magnetosphere, the diversity of the Galilean satellites, the physical characteristics, composition and geology of their surfaces, with a resolution and coverage far beyond what was achieved by Galileo. It will determine their internal structure and the existence of subsurface oceans. It will study the Laplace resonance and its role in maintaining tidal heating. Constraints for the habitability of Europa over geologic timescales will be inferred from monitoring in the visible and infrared combined with precise determination of the satellites' orbital positions. With two orbiters around Europa and Ganymede, two satellites with many geophysical similarities and some important differences, it will be possible to perform an in-depth comparison of this pair of "false twins", to understand the origin of their geophysical dichotomy and to better understand the unique characteristics of Europa which may make it habitable. With its combination of two (possibly up to three) spacecraft, the EJSM mission will ideally address the top science goals described above.

The core of the EJSM mission is to perform a comprehensive study of the four Galilean satellites by optimizing the roles of each platform. JEO will focus on the two "rocky" inner Galilean satellites, Io and Europa. Before going into orbit about Europa, JEO will perform several fly-bys of Io. Following a similar approach, JGO will focus on the two "icy" outer Galilean satellites, Ganymede and Callisto. The main objectives of the JGO are: observations of Jupiter and its magnetosphere, and investigation of the "icy" moons Ganymede and Callisto. For this purpose, before going into Ganymede orbit, JGO will perform multiple fly-bys of Callisto, to provide a firm basis for a comparative understanding of that pair.

The main science objectives of JGO can be summarized as follows:

- A. Jupiter:** study the thermal structure, dynamics and composition of the different layers of Jupiter's atmosphere; coupling processes in the atmosphere; internal structure of Jupiter.
- B. Ganymede and Callisto:** presence and location of liquid water; Ganymede's intrinsic magnetic field; geology and past and present surface activity; surface composition and physical properties; the degree of internal differentiation; the moon's exospheres.
- C. Jovian Magnetosphere:** 3-D properties of the magneto-disk plasma sources and mass loading coupling processes (magnetosphere, ionosphere, thermosphere) aurorae and radio emission the response to the solar wind, high energy particles.
- D. Satellite System:** temporal variations in Io's activity the moons' interactions with the magnetosphere gravitational coupling and long-term tidal evolution of the Galilean Satellites, small satellites' composition and dynamics

JGO is a 3-axis stabilized spacecraft with a dry mass of 1275 kg and a wet launch mass of 3493 kg. Electrical power is generated by  $\sim 51\text{m}^2$  GaAs solar cell arrays. 73 kg of scientific (model) payload are accommodated. The propulsion system is pure chemical; for tele-communications and telemetry a 2.8 m High Gain Antenna is used in X-band. The main radiation belts of Jupiter are avoided during all mission phases, therefore the total dose for the onboard systems and P/L is kept below 85 krad with 8 mm aluminium equivalent shielding. The current scenario foresees a launch of the JGO on 11 March 2020 with an Ariane 5 ECA into direct escape to Venus.

For the interplanetary cruise phase a Venus-Earth-Earth gravity assist sequence (VEEGA) is planned with Jupiter Orbit Insertion (JOI) on 4 February 2026. This results in a total transfer time of 5.9 years. A Ganymede gravity assist manoeuvre will be performed directly before JOI into a

13 x 245  $R_J$  elliptical orbit. This is followed by Ganymede resonant orbits (7:1, 4:1 and 3:1 resonance) with further 5 Ganymede swing-by's, used for reduction of the apo-Jove at low  $\Delta V$ , change the inclination and to reduce the infinite velocity with respect to Ganymede. During this phase the atmosphere and magnetosphere of Jupiter will be studied.

The next phase is a Jupiter-centric orbit with Ganymede and Callisto fly-by sequence (GCGC), followed by a 2:3 and 1:1 resonant orbit with Callisto, allowing for a dedicated Callisto science phase (383 day duration) with 19 close Callisto fly-bys. The closest approach to this moon will be 200 km for each of these encounters at various Callisto latitudes and longitudes.

This is followed by the Ganymede science phase with a Jupiter-centric Callisto-Ganymede-Ganymede (CGG) fly-by sequence to prepare for a low  $\Delta V$  insertion into near-polar highly elliptical (200x6000km) Ganymede orbit, lasting 80 days. This is followed by circularization to a near-polar circular 200 km orbit, lasting 180 days.

The current baseline for decommissioning of JGO is to impact the spacecraft onto the surface of Ganymede 8.9 years after launch.

## 2 JUPITER GANYMEDE ORBITER SCIENCE BACKGROUND

### 2.1 Introduction

The LAPLACE proposal (Blanc et al., 2008) was submitted to ESA in response to the first call for implementation of the Cosmic Vision programme. By choosing the Jupiter system and its Galilean satellites as its main target, LAPLACE indeed addresses several major themes of Cosmic Vision: how do planetary systems form, how do they work, are they habitable? On the U.S. side, two flagship missions addressing respectively Europa and the Jupiter System were selected for further study. The Europa Jupiter System Mission (EJSM) builds upon the heritage of LAPLACE and of the two flagship missions both in terms of scientific contents and of mission architecture. Just as proposed for LAPLACE, EJSM is a two-platform mission. It includes the Jupiter Europa Orbiter (JEO), that would be provided by NASA and the Jupiter Ganymede Orbiter (JGO), that would be provided by ESA. EJSM may be augmented by a third platform, the Jupiter Magnetospheric Orbiter (JMO), dedicated to in-depth observations of the magnetosphere, if JAXA joins the venture during the next phase, after the down-selection. Adding JMO to EJSM will offer a unique capacity of 2-point and 3-point investigations of this object, via synergistic observations with JGO and JEO.

JEO and JGO perform an in-depth study of the Jupiter system, its satellite system, atmosphere and magnetosphere and each spend the second phase of the mission in orbit around one of the Galilean satellites, JEO around Europa and JGO around Ganymede. Extensive synergistic scientific utilisation of the two platforms will maximise the overall scientific return of EJSM far beyond the mere addition of the science returns from each platform taken separately.

The Jupiter Ganymede Orbiter (JGO) is the mission component to be developed by ESA, with Ganymede's orbit as its final destination. This section describes the science that JGO will address. We first introduce the overall scientific objectives of EJSM, then describe in the general context of EJSM the science goals and then the specific measurement objectives assigned to JGO in more detail. We also summarise the scientific synergies between JGO and JEO.

### 2.2 Science Goals and context of the EJSM mission

#### 2.2.1 Overarching Theme of the EJSM mission

Some 400 years ago, discovery of the four large moons of Jupiter by Galileo Galilei changed our view of the universe forever. Today Jupiter is the archetype for the giant planets of our Solar System, and for the numerous giant planets now known to orbit other stars. Jupiter's diverse Galilean satellites—three of which are believed to harbour internal oceans—are central to understanding the habitability of icy worlds.

By understanding the Jupiter system and unravelling its history from origin to the possible emergence of habitats, we will know better how gas giant planets and their satellites form and evolve. Perhaps more importantly, we will shed new light on the potential for the emergence of life in our galactic neighbourhood and beyond. Thus, the overarching theme for EJSM has been formulated as:

***The emergence of habitable worlds around gas giants.***

To address this theme, EJSM will explore the Jupiter system and study the processes leading to the diversity of its associated components and their interactions. The focus is to characterize the conditions that may have led to the emergence of habitable environments among its satellites, with special emphasis on the two internally active ocean-bearing worlds, Europa and Ganymede.

2.2.2 Science goals of EJSM

The overarching theme of EJSM can be developed into three key science goals for the mission.

***Goal 1: Determine whether the Jupiter System harbours habitable worlds***

Europa is believed to have a saltwater ocean beneath a relatively thin and geo-dynamically active icy crust (Figure 1). Europa is unique among the large icy satellites because its ocean is in direct contact with its rocky mantle beneath, where the conditions could be similar to those on Earth's biologically rich sea floor. The discovery of hydrothermal fields on Earth's sea floor suggests that such areas are excellent habitats, powered by energy and nutrients that result from reactions between the sea water and silicates. Consequently, Europa is a prime candidate in the search of habitable zones and life in the Solar System. However, the details of the processes that shape Europa's ice shell, and fundamental question of its thickness, are poorly known.

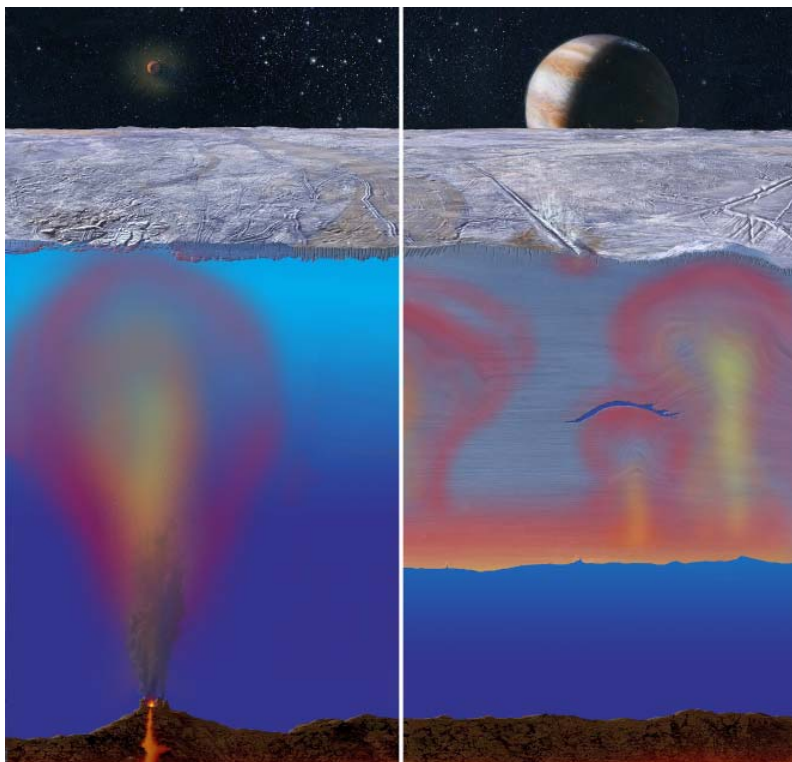

Figure 1: The NASA Jupiter Europa Orbiter (JEO) will address the fundamental issue of whether Europa's ice shell is thin (left) or thick with developments of internal convective structures (right), with different implications for processes and habitability. In either case, the ocean is in direct contact with the rocky mantle below, which can infuse the chemical nutrients necessary for life.

Ganymede is believed to have a liquid ocean sandwiched between a thick ice shell above and high-density ice polymorphs below, more typical of volatile-rich icy satellites. It is the only satellite

known to have an intrinsic magnetic field, which makes the Ganymede-Jupiter magneto-spheric interactions unique in our Solar System (Figure 2).

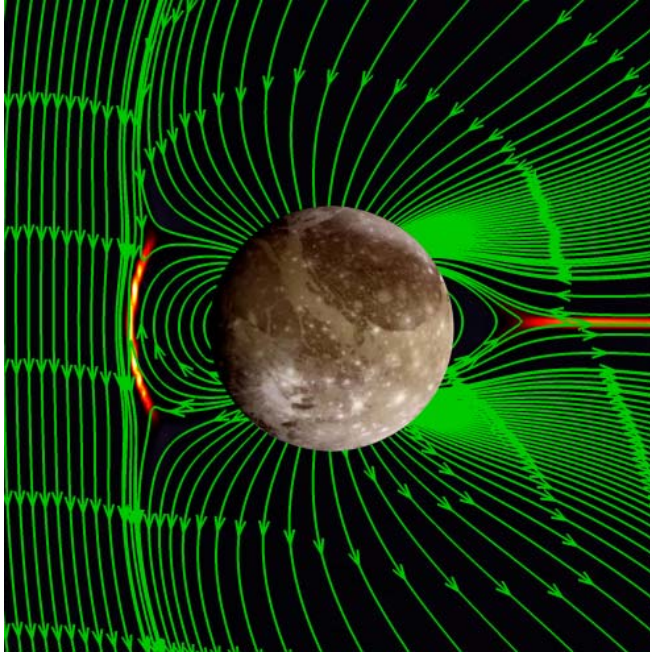

Figure 2: The ESA Jupiter Ganymede Orbiter (JGO) will determine how Ganymede's unique magnetic field interacts with Jupiter's, how the interactions vary with time, and the roles of a convecting core and internal ocean.

EJSM will undertake in-depth comparisons of Europa and Ganymede, the two differentiated ocean-bearing bodies of the Galilean satellite system, to establish their characteristics with respect to geophysical activity and habitability. To this end, NASA's JEO spacecraft will investigate Europa in detail while ESA's JGO spacecraft will focus on Ganymede (see story "why Ganymede?").

For Europa and Ganymede, both mission elements have objectives to:

- Determine the presence and extent of sub-surface oceans and their interaction with the deeper interior.
- Characterize the ice shells and any subsurface water, including the heterogeneity of the ice, and the nature of surface-ice-ocean exchange.
- Characterize the deep internal structure, differentiation history, and (for Ganymede) the intrinsic magnetic field.
- Compare the exospheres, plasma environments, and magnetospheric interactions.
- Determine global surface compositions and chemistry, especially as related to habitability.
- Understand the formation of surface features, including sites of recent or current activity, and identify and characterize candidate sites for future *in situ* exploration.

**Goal 2: Characterize the processes within the Jupiter System**

The Jupiter system includes a broad diversity of objects, including Jupiter itself, its magnetosphere, 55 currently known outer irregular satellites, the Jovian ring system, four small inner satellites, and the four large Galilean Satellites: Io, Europa, Ganymede, and Callisto.

The Galilean satellite system plays a central role in the description and understanding of the Jupiter system as a whole. The gravitational coupling of the Galilean Satellites and the long-term tidal evolution of the moons has important consequences in the Jovian system. The characterization of each satellite and Jupiter itself by JEO and JGO in a synergistic and complementary way will yield the pieces of information which have to be integrated into the theories of the origin and evolution of the whole system. Europa's habitability including stable conditions for an ocean may be the most remarkable consequence of these coupling processes.



## Why Ganymede ?

1. Ganymede is among the Earth and Mercury one of only three solid planetary bodies in the solar system at which a present-day intrinsic magnetic field was detected. Comparative studies of Ganymede and Europa will give insight in the conditions required for dynamo activity and its maintenance in icy moons and in terrestrial planets.

2. Ganymede is believed to contain a global subsurface water ocean. Large amounts of liquid water (presumably including salts), the intrinsic magnetic field and Jupiter's magnetosphere could therefore interact over long periods of time. This may have important implications on the habitability of the moon.

3. Because of the Laplace resonance Io, Europa and Ganymede exchange orbital energy and angular momentum. The response to tidal forces exerted by Jupiter on Ganymede will thus constrain not only the evolution of Ganymede itself, but also the long-term evolution of Io and Europa, including also implications on the thermal conditions for an ocean on Europa.

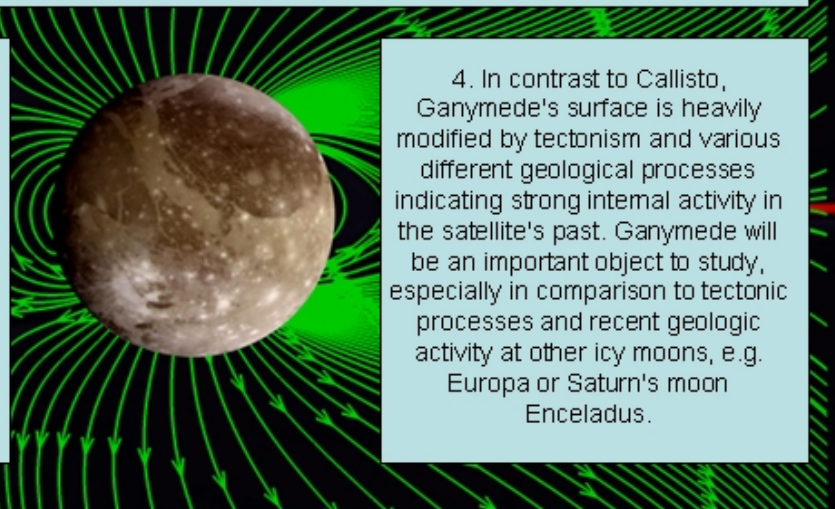

4. In contrast to Callisto, Ganymede's surface is heavily modified by tectonism and various different geological processes indicating strong internal activity in the satellite's past. Ganymede will be an important object to study, especially in comparison to tectonic processes and recent geologic activity at other icy moons, e.g. Europa or Saturn's moon Enceladus.

5. Past thermal and geological activity has been suggested to be related to the entrance of Ganymede into the Laplace resonance. To constrain the age and duration of phases of activity on Ganymede will be crucial to study the origin, age and history of the resonance.

6. Ganymede, its magnetosphere and its tenuous atmosphere are embedded in Jupiter's vast magnetosphere giving rise to various unique processes and interactions of particles and fields. Ganymede's intrinsic field partially shields the surface from the direct flux of particles accelerated in the Jovian field. It is an ideal place to study different processes and degrees of modifications of icy satellite surfaces by radiation.

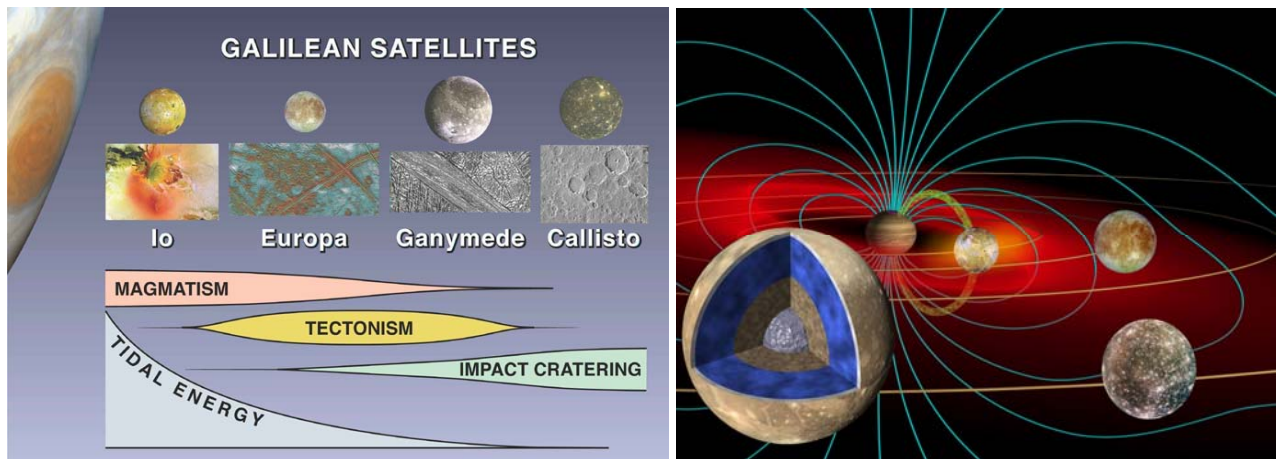

**Figure 3: Left: With respect to surface activity and different processes, the Galilean Satellite system appears to have systematic trends as a function of distance from Jupiter (taken from Bagenal et al., 2004.). Right: A major goal of EJSM is to understand these trends from origin to the present state and to characterize the resulting diversity of the moons including their gravitational and magnetospheric coupling processes.**

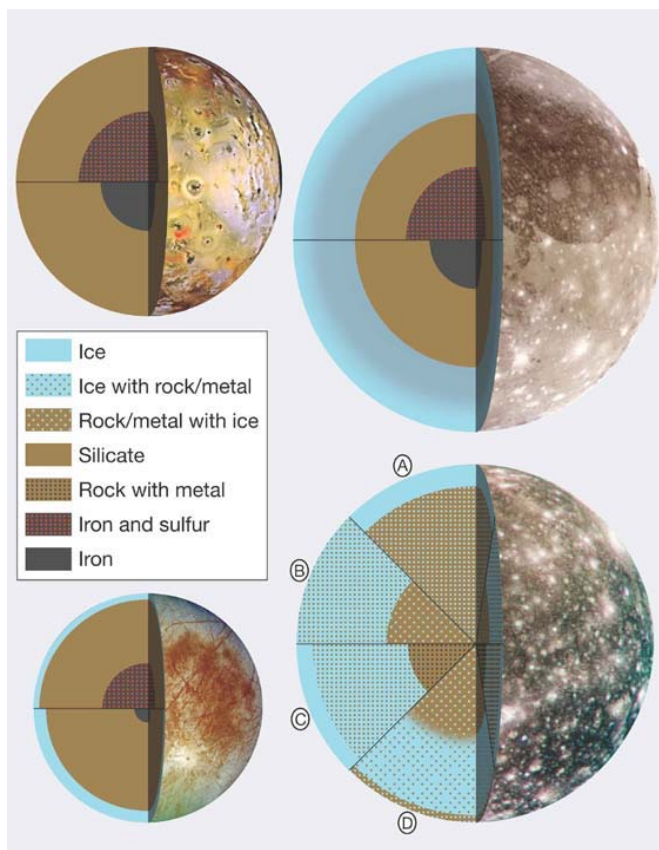

**Figure 4: Possible models for the internal structures of the four Galilean satellites. It still remains unclear if and how much of the H<sub>2</sub>O ice is liquid inside Europa, Ganymede and Callisto. In contrast to the other Galilean Moons, Callisto is only partially differentiated. Taken from Bagenal et al., 2004.**

*Jupiter's internal and atmospheric structure are intimately coupled to the greater Jovian system environment (see Figure 3 and Figure 4). EJSM will extend Juno's investigations to the lower latitudes of Jupiter's atmosphere while focusing on complementary scientific questions through*

measurements of the troposphere, stratosphere, thermosphere, and ionosphere. It will study how Jupiter's atmosphere couples to its interior and its magnetosphere.

*Jupiter's magnetosphere* is closely coupled to the upper atmosphere and interior by electrodynamic interactions. This giant magnetized environment, driven by the fast rotation of its central spinning zone and populated by ions coming from its moons, is the most accessible and intense environment for direct investigations of general astrophysical processes. EJSM will measure the dynamics of the Jovian magnetodisk (with angular momentum exchange and dissipation of rotational energy), determine the electro-dynamic coupling between the planet and the satellites, and assess the global and continuous acceleration of particles.

### ***Goal 3: Gain new insight into the origin of the Jupiter system***

One of the most important aspects of Solar System studies is the identification of the processes leading to the formation of gas giant planets. EJSM will provide new crucial information for this question by providing an unprecedented understanding of the interior structure and properties of the Galilean satellites (especially Europa and Ganymede), by allowing us to infer the bombardment history on the Galilean satellites for application to the Jupiter system, and comparative compositional study of the satellites, particularly the irregular satellites which may be the remnants of the population of planetesimals from which Jupiter's putative core accreted. In addition, this "core accretion scenario" may, in complement to JUNO's findings, be tested using a seismology experiment which will be assessed during the next mission study phase. Along with a better understanding of Jupiter's composition, all these elements will concur to improve our knowledge of the thermodynamics of the primordial circumplanetary disk from which Jupiter formed.

#### 2.2.3 Relevance to Cosmic Vision Themes

The study of the Jupiter system and its habitability has deep implications for improving our understanding of extrasolar planets and planetary systems. Jupiter is a template, accessible in the Solar System, for the many gas giants now discovered around other stars. The question of the habitability of their satellites can reasonably be studied, for a long time, only through the example of Jupiter, hence the universal consequence of the possible finding of a habitat for life there.

To be more specific, EJSM will address the following themes within the Cosmic Vision framework:

Theme 1: *What are the conditions for planet formation and the emergence of life?*

Theme 2: *How does the Solar System work?*

Within Theme 1 EJSM will address sub-theme *1.3 Life and habitability in the Solar System* by exploring the surface and sub-surface of Europa in particular, but also those of Ganymede and Callisto including their subsurface water oceans and their environment in the Jupiter system.

It will address *1.1 From gas and dust to stars and planets* by studying the composition and interior of Jupiter and its satellites which is essential to understand the origin of the system and its relation to other regions of planet formation in our galaxy. It will contribute to *1.2 From exoplanets to biomarkers* by studying Jupiter and its potentially habitable satellite system as an analogue to Jupiter-like planets and their as yet undetected satellite systems around other stars.

Within Theme 2 it addresses the following sub-themes:

- 2.1 *From the Sun to the edge of the Solar System* by studying the plasma and magnetic field environment in the Jovian system (as a Solar System in miniature) as well as the magnetosphere of Ganymede. The radiation environment including its consequences for habitability will in particular be investigated at Europa and Ganymede.

- 2.2 *The Giant planets and their environments* by studying the atmosphere of Jupiter, and the interiors, oceans and icy crusts of Europa, Ganymede and Callisto. It studies the diversity of the satellite system and the complex coupling processes in the Jovian environment that are key to understanding the evolution of the satellites.

By including orbiters around Europa and Ganymede and by operating two spacecraft simultaneously in the Jupiter system, EJSM is the next logical major step after Galileo and the Juno Mission towards a systematic exploration of the giant planet, its satellites and magnetosphere. EJSM lays the pathway for the next phase of Jupiter system exploration possibly including new-generation Jupiter atmospheric probes and Europa or Ganymede landers which could – building on the outcome of EJSM – search for signs of life on these icy moons in a very focused way.

During the next study phase the possible inclusion of the gravity advanced package (GAP) will be assessed. GAP would address Theme 3 *What are the fundamental physical laws of the universe?* by searching for deviations from the standard theories of gravity.

#### 2.2.4 Observation strategy for EJSM

EJSM has been tailored to observe all main components of the Jupiter system and untangle their complex interactions.

Central to this system, the four Galilean satellites span a broad range of possible compositions of solid planetary bodies, from pure silicate/metal bodies (Io) to dominantly icy ones (Callisto). They can be divided into two pairs, two dominantly rocky ones (Io and Europa), and two dominantly icy ones (Ganymede and Callisto). In order to place Europa and Ganymede in the right context and to fully understand the Galilean satellites as a system, our observation strategy with EJSM can be described in several steps:

- 1. Conduct an in-depth comparative study of these two pairs (Europa-Io and Ganymede-Callisto), with a special focus on the two differentiated ocean-bearing bodies, Europa and Ganymede, which JEO and JGO, respectively, will fully characterise. Then, extend our study to the whole satellite system;
- 2. Study the other two components of the Jupiter system: Jupiter and its magnetosphere.
- 3. Study coupling processes inside the Jupiter system, with emphasis on the two key coupling processes within that system: gravitational coupling, which ties together Jupiter and its satellite system, and electrodynamic interactions which couple Jupiter and its satellites to its magnetosphere and magnetodisk.

The EJSM mission architecture offers unique opportunities for synergistic, coordinated observations between the two platforms. This simultaneous observation strategy from two locations within the Jupiter system will significantly enhance the science returns with respect to both mission elements (JEO and JGO) taken individually. Specific examples of synergistic observations are shown in Table 5 below. When JGO (resp. JEO) will be inside the magnetosphere, JEO (resp. JGO) observations in the solar wind will help untangle the solar-wind

driven and internally driven processes in magnetospheric dynamics; observations of Io's volcanic activity by JEO will be placed in the global context of global remote sensing of the Io torus by JGO; studies of dynamic phenomena such as the meteorology of Jupiter, or activity at the surface of a satellite, will be considerably enhanced by simultaneous observations from JEO and JGO at different viewing angles, angular resolutions, and possibly wavelength ranges. As shown in the joint timeline of the JEO and JMO missions, the relative phasing of the two missions can be optimized to offer many opportunities of these kinds, combining remote sensing with in-situ measurements, or observations of the same target from different angles, wavelengths and resolutions.

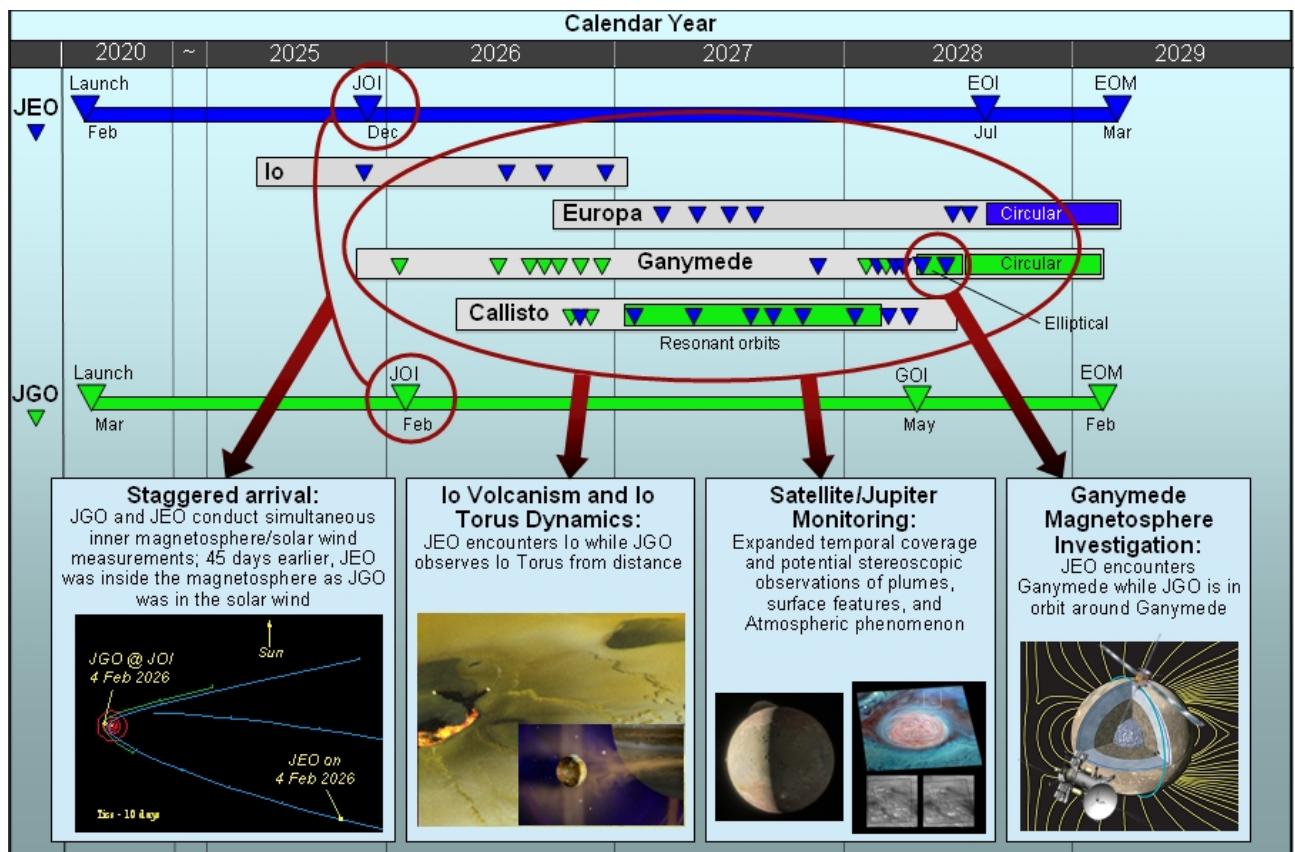

Figure 5: Joint time line of the JEO and JGO elements of EJSM.

## 2.3 Science goals of JGO

Following the observation strategy outlined in 2.2.4, we will in the following outline our science goals for the different components of the Jupiter system, then for the system as a whole. We start with our final destination, Ganymede, then address Callisto, the other Galilean satellites and the satellite system as a whole. We move to the other two main components of the system, Jupiter itself and its magnetosphere, and finally address global system coupling processes.

### 2.3.1 Ganymede.

Ganymede is the largest satellite of the Solar System. It is a typical icy satellite, mainly composed of H<sub>2</sub>O-ice and silicate rock (including metal) in roughly equal amounts (Schubert et al., 2004). In the following we will describe the scientific goals which will be fully or partly addressed by JGO in order to characterize Ganymede as a planetary object including its potential habitability.

**Ice shell and ocean:** Observational evidence for the presence of a global water-ocean on Ganymede has been indirectly obtained by the Galileo mission with the detection of an induced magnetic field generated at shallow depth (~100 km) in response to the time-variable rotating magnetosphere of Jupiter. However, the available data is inconclusive at Ganymede because of the complex interaction of the induced field, Ganymede's intrinsic field, Jupiter's magnetosphere and the plasma environment (Kivelson et al. 2002, 2004). The unquestionable proof for the presence (or absence) of a subsurface water ocean at Ganymede is therefore a high-priority goal for JGO. The tidal deformation of the surface, which would be much larger with a liquid layer underneath the icy shell (Moore and Schubert 2003) would provide compelling evidence for a subsurface liquid layer. An ocean, located between ice-I at the top and high-pressure ice phases at the bottom would be consistent with models on Ganymede's interior and evolution. However, the depth and composition of the ocean, as well as the dynamics and communication of the ocean with both the deep interior and the upper ice shell remain unclear. Furthermore, it is unknown if liquid water or compositional boundaries exist in the shallow subsurface ice and how the dynamics of the outermost ice shell is related to geologic features and surface composition. The electrical conductivity which results from the intrusion of minerals into the water can help characterize the potential habitability of an ocean inside Ganymede.

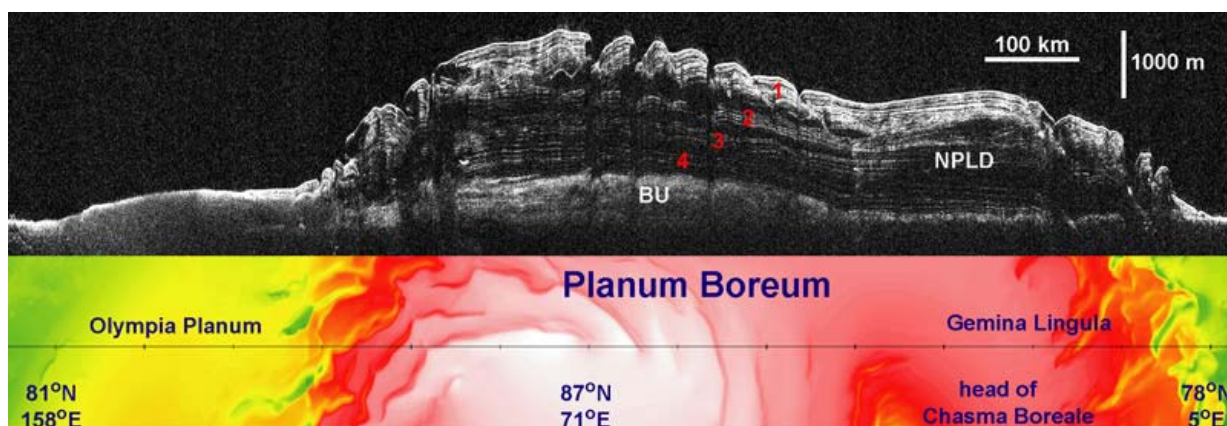

**Figure 6:** Structure in the ice sheet of Mars' south-polar cap as revealed by radar on Mars Reconnaissance Orbiter. The stratification of the ice sheet and its relation to surface topography is evident. NASA/JPL-Caltech/University of Rome/SwRI.

**Key questions:** *Is (or was) there liquid water inside Ganymede? If so, what is (or was) its spatial distribution? How did the internal ocean evolve with time? Is the ocean a potential habitat? How thick is the ice-layer, and does liquid water exist within the ice? Is the ice shell convecting? What is the relation between the thermal and dynamical state of the ice shell and geologic and compositional surface features on Ganymede?*

**Ganymede's magnetosphere:** A unique characteristic of Ganymede is its intrinsic magnetic field generated in the satellite's metallic core, and comparable to dynamo-activity in the Earth and Mercury (Kivelson et al., 2002). Ganymede is so far the only known moon in our Solar System to possess its own intrinsic mini-magnetosphere (about the size of Mercury's magnetosphere) embedded within the Jovian magnetosphere. The investigation of Ganymede's magnetosphere and its deep interior structure are very important to understand the Jovian system as a whole. The interplay between intrinsic field, induced magnetic fields generated in the subsurface ocean, and the Jovian magnetosphere will be characterized by JGO during a dedicated elliptical orbit phase. In this phase the spacecraft will go in and out of the Ganymede magnetosphere at various magnetic latitudes so that the boundary between Ganymede's and Jupiter's magnetic fields will be extensively investigated. Comparing Ganymede with Europa, which – despite its metallic core – is lacking an intrinsic magnetic field will give further insight in the different evolutionary paths of the Galilean satellites.

**Key questions:** *What is the intrinsic magnetic field strength of Ganymede? What is the size of Ganymede's magnetosphere and how does it vary spatially and temporally? What are the particle distributions of various species inside Ganymede's magnetosphere? Where is the boundary between open and closed field lines and what is the relationship between the location of the boundary and surface and exosphere features? Which processes are important to better understand the interaction between Ganymede's magnetosphere and Jupiter's magnetosphere?*

**Geology:** Ganymede's surface displays two types of terrain (1) the ancient dark terrain, which is heavily cratered and comprises about 1/3 of the surface and (2) the bright grooved terrain (2/3 of the surface) which is substantially younger and cross-cuts the dark terrain in 10 to 100 km wide swaths (Pappalardo et al., 2004). Besides craters and impact basins, the surface of Ganymede reveals a number of geologic features, indicating past geologic activity and resurfacing (Figure 7)

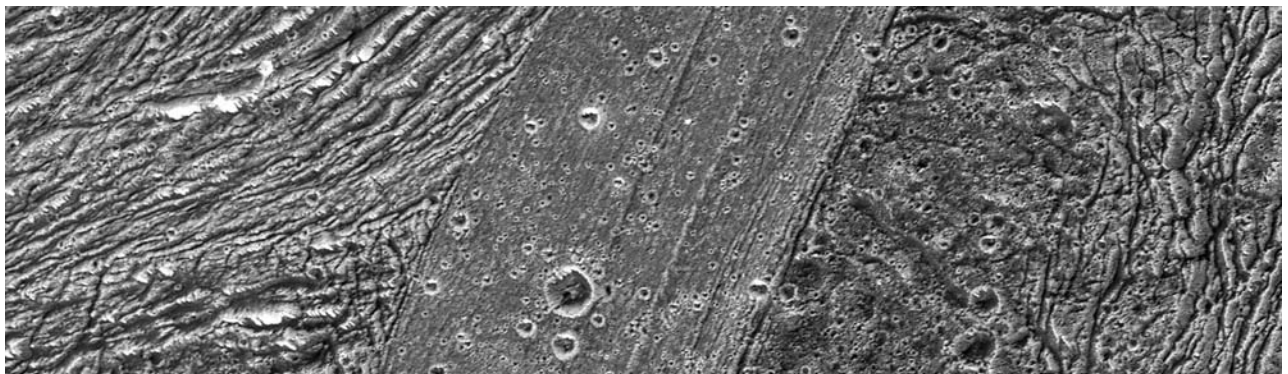

**Figure 7:** Ganymede's surface displays different types of terrain and is heavily modified by tectonism (89x26 km). NASA/JPL

**Key questions:** *What are the relative roles of geological processes (tectonism, volcanism, mass wasting) that have shaped Ganymede's surface? What is the age of the grooved terrain, and how*

*extended was its formation period? Is Ganymede still geologically active today? How is the formation of grooved terrain related to entrance into the Laplace resonance and to other processes, e.g. internal differentiation, phase changes and convection?*

**Surface Composition and physical properties:** As revealed by the Galileo mission there are substantial amounts of non-ice components present at the H<sub>2</sub>O-ice dominated surface of Ganymede. The nature and origin of these species which may have been derived from a subsurface briny layer of fluid (McCord et al., 2001) are still debated. The relation of physical properties of the ice (e.g., grain size) and of the regolith to geological features and external processes still needs to be understood. The effects of shielding of Ganymede's intrinsic field at equatorial to mid-latitudes from high-energetic particles and its implications on surface processes up to possible consequences for Ganymede's habitability still need to be studied.

Key questions: *What are the non-ice components at the surfaces on Ganymede? How are they linked to the interior and to the exosphere of Ganymede? Is the non-ice material a sample of a briny ocean or is it of external origin? How do particles, magnetosphere and exosphere interact with the Jovian magnetosphere and what are the implications for Ganymede's surface and ice layer? Do organic compounds exist on Ganymede's surface? How are they affected by radiation?*

*What are the implications of shielding by Ganymede's magnetic field on chemical and physical surface processes?*

**Deep interior:** Interpretation of Galileo gravity data suggests that Ganymede is fully differentiated into an iron core, a rocky mantle, a high-pressure ice layer and an outer ice-I layer (Schubert et al., 2004). This is consistent with the generation of an intrinsic magnetic field in the iron core. However, it stands in contrast to the incomplete differentiation of Callisto. How these different states came to be is one of the major unanswered questions after the Galileo mission which will be addressed by investigating the interiors of both satellites in detail. JGO's trajectory including an orbital phase around Ganymede and many flybys with differing geometries at Callisto will be well-suited for such an investigation. Due to the geometry of the limited number of Galileo flybys it could not be inferred if Ganymede actually is in hydrostatic equilibrium. JGO will test the assumption of hydrostatic equilibrium providing an essential piece of information necessary to interpret the gravity data and to improve the constraints on the thicknesses and densities of the individual layers inside Ganymede. The yet unknown high-order gravity field components will be measured from low-altitude orbit providing the link between deep interior, the regional and local density structure and the corresponding topography and geology. JGO will search for mass anomalies inside the satellite being indicative of internal dynamical processes.

Key questions: *What are the thickness and depth of the different layers and phase transitions inside Ganymede? Is the satellite in hydrostatic equilibrium? Are there mass anomalies related e.g. to internal activity inside Ganymede? Why is Ganymede fully differentiated while Callisto's ice and rock+metal have separated only partially?*

## 2.3.2 The Satellite system

### 2.3.2.1 Callisto

Ganymede and Callisto are thought to have formed after the Jovian subnebula was sufficiently cool to allow the incorporation of ices into solid clusters and to prevent the vaporization of volatiles in ice rich planetesimals that have migrated into the subnebula. Callisto's ancient cratered surface that has – in contrast to Ganymede's – not been modified significantly by internal activity, is thus representative of the conditions in the early Solar System and hence of particular interest.



Callisto's radius is around 200 km smaller than Ganymede's and its mass roughly 70% that of Ganymede. If Callisto is in hydrostatic equilibrium, an assumption usually made but not yet confirmed by the acquired data,

the Galileo gravity field measurements suggest a partially differentiated interior structure of Callisto (Schubert et al., 2004). An induced magnetic field detected by Galileo provides evidence for an extant subsurface water ocean on Callisto (Zimmer et al., 2000). This seems contradictory since the formation of an ocean is generally attributed to run-away differentiation. How the incomplete differentiation and the presence of an ocean can be combined in a consistent evolution scenario still remains unclear. JGO will address that question during a sequence of low-altitude flybys with differing geometries. It will be inferred if Callisto is in hydrostatic equilibrium. On the basis of improved gravity data in combination with the data on the induced magnetic fields it will be possible to distinguish between the different Callisto models as shown in Fig.4. Constraints on the spatial distribution of rocks, ice and liquid water will be improved. This will be set into context with different accretion scenarios, e.g. as a consequence of the satellites' different locations in the Jovian subnebula and the subsequent evolution of Ganymede into the Laplace resonance (Canup and Ward, 2002).

The measurement of chemical and isotopical composition of the Jovian satellites has the potential to provide essential clues on their formation process. Determining the abundance of hydrocarbons and CO<sub>2</sub> with respect to water ice from accurate spectroscopic measurements would particularly help constrain the volatile abundance (C/H ratio) of the Jovian satellites.

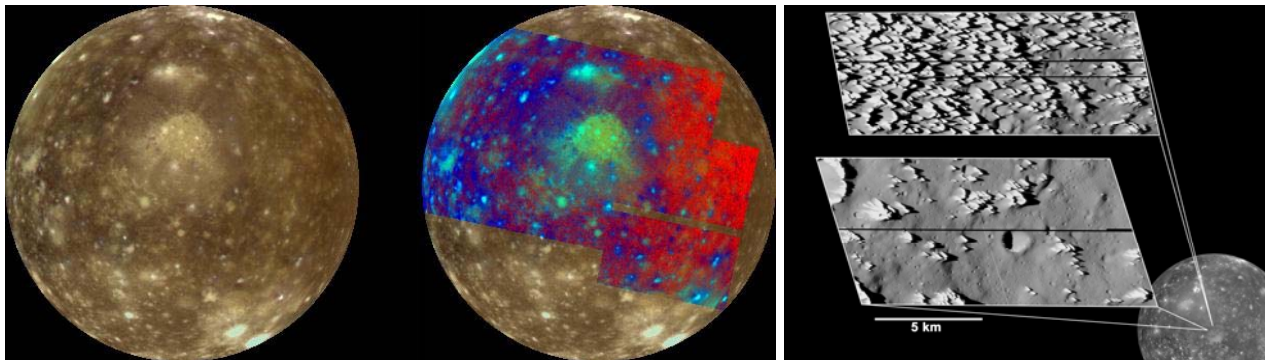

**Figure 8: Left: Callisto's heavily cratered surface and gradual colour variations across the moon's hemisphere that may be due to material implemented from space. NASA/JPL. Right: Knobby terrain on Callisto as an example of erosional degradation processes. The bright knobs are about 80 to 100m tall. The lower insert most likely is more eroded as indicated by dust filling the low-lying areas. NASA/JPL/Arizona State University**

Callisto's old, heavily cratered surface shows no sign of significant endogenic activity and resurfacing. The surface thus preserved the cratering history over most of the Solar System's history. However, as revealed in high-resolution Galileo images, the surface has been substantially modified by erosion and sublimation degradation processes creating surface features, e.g. the knobby terrain that are unique among icy satellite surfaces (Moore et al., 2004). Imaging data of Callisto's surface is still sparse on regional and local scales. This will be significantly improved by mapping the surface at different resolutions with JGO during the Callisto flyby phase. The interaction with the Jovian environment, evident in the erosion processes but also in compositional differences, plays a key role in the modification of Callisto's surface that will be studied by JGO. It has been suggested that CO<sub>2</sub> contained in clathrate hydrates in the near-surface layer of Callisto over geologic time sublimed when exposed to the surface, giving rise to surface degradation and exosphere formation. Spectral characterization of the physical (e.g.,

grain size) and chemical properties on Callisto's surface as well as improved data on the composition of the exosphere will provide clues to understand surface degradation processes.

**Key questions:** *Is there liquid water inside Callisto? If so, what is its spatial distribution? How did the subsurface water ocean evolve with time? How thick is the ice-layer, and does liquid water exist within the ice? What are the non-ice components at the surface on Callisto? How are they linked to the interior and exosphere? What are the rates of sublimation-degradation, a major process of surface modification on Callisto? How is the crater-size distribution on Callisto related to Ganymede's old terrain and to other satellites in the outer Solar System? How are rock and ice distributed within Callisto's interior? Is Callisto in hydrostatic equilibrium? Why did Ganymede and Callisto evolve so differently although they are so similar in bulk composition and size?*

### 2.3.2.2 *Io and Europa*

The two inner Galilean satellites, Io and Europa, will be investigated in detail by JEO. However, there are some complementary objectives that can be addressed by JGO remotely (objectives addressing the evolution of the satellite system itself are summarized in 2.3.5). The measurements at Io and Europa are mostly related to temporal phenomena including variations in Io's volcanic activity. Plume activity as well as different types of thermal activity on Io will be monitored throughout the mission. The spatial distribution of volcanic centres on Io and its relation to the distribution of internal heat from tidal friction still remains unclear.

Other transient phenomena, e.g. the satellites auroral activity and temporal changes in the satellites atmospheres will be studied. An important objective that can only be studied with two or more spacecraft in the Jupiter system is how transient phenomena in the magnetosphere affect the individual moons. (spatially and temporally). Simultaneous observations from remote sensing instruments onboard JGO and JEO can potentially enhance spatial and spectral coverage of atmospheric measurements; allow for synergistic observations at different wavelengths; provide greater spatial coverage to resolve atmospheric asymmetries. Spacecraft radio occultations will help infer atmospheric conditions and plasma interactions of the moons. While JEO is imaging Io's volcanic activity and plasma torus JGO will monitor plasma loading processes in the outer magnetosphere. In addition simultaneous long-term stereo imaging of Io's torus will infer the 3-D structure and dynamics of the torus.

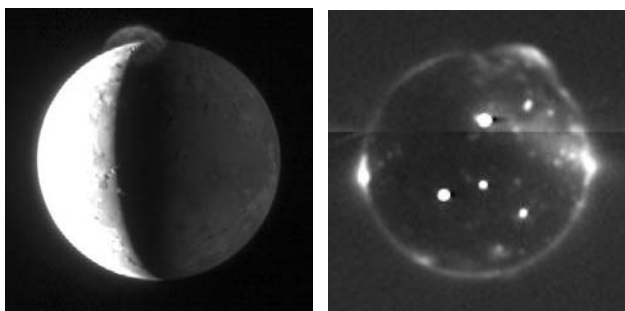

**Figure 9:** Eruption of Io's volcano Tvashtar (left) and glowing hot lava, auroral displays in Io's tenuous atmosphere and volcanic eruptions on Io's night side (right) as observed from outside Callisto's orbit during the New Horizons flyby. NASA/John Hopkins University APL/Southwest Research Institute

**Key questions:** *How does the volcanic activity on Io vary spatially and on the timescale of minutes (eruptions), hours (activity at individual sites), days (order of Io's orbit around Jupiter), years and on tens of years (by comparison with Voyager and Galileo data)? How variable is Io's atmosphere (temporally and spatially)? Does it drive plasma torus variability? Why is Europa's oxygen emission (indicative of its O<sub>2</sub> atmosphere) non-uniform? What is the composition of the atmospheres of Europa and Io and how do they compare to those of Ganymede and Callisto?*

### 2.3.2.3. The other satellites and rings

#### Jupiter Irregular satellites

The study of the irregular satellites is relevant since these objects are remnants of the early evolution of the Solar System and hence can provide new insights into the history of the Jovian system. The observation of irregular satellites can give clues on the role of impacts in the reshaping of the surface, and on the source of dust in the Jupiter system.

Key questions: *What is the origin and the physical nature of the irregular satellites? Which physical process is at the basis of their capture? Did their evolution inside the Jovian system preserve traces of their formation epoch?*

#### The ring system

In contrast to Saturn's ring system, that of Jupiter is faint and consists mainly of micron-sized dust. The Jovian ring system has three components. The main ring, the brightest one, has Adrastea, a tiny ring-moon, skimming through its outer edge and is  $< \sim 30$  km thick. Near its inner boundary at about  $1.71 R_J$ , the main ring expands into the vertically extended halo (Showalter et al. 1987; Ockert-Bell et al. 1999). The halo is radially confined, seeming to fade significantly inside  $1.29 R_J$ , and vertically extended, rising to a full thickness of  $\sim 20\,000$  km (about  $10^\circ$ ) although the majority of material falls within 1000 km of the ring plane. Two "gossamer" rings that stretch beyond the main ring, one immediately interior to Amalthea, another one interior to Thebe, with more material lying outside Thebe's orbit, were discovered in a single Voyager image and surveyed in great detail by Galileo, Keck and HST. Since the ring particles have been shown to have orbital inclinations matching those of their bounding moons, the gossamer rings are likely composed of inward-drifting particles that have been ejected from these bodies due to impacting meteoroids (Burns et al. 1999). Physical characterization and chemical characterization of the ring system, in three dimensions and over different timescales, is a desired goal for EJSM. In order to achieve this goal, global imaging of the entire ring system over a range of timescales and in a wide range of solar phase angles is needed, as well as multiwavelength characterization and mapping of the ring particles composition and photometric behaviour.

Key questions: *What is the full 3-dimensional structure of Jupiter's ring system? Does the ring system evolve and, if so, on which timescale? What is the chemical composition of the three components of the ring system? What are the physical properties of the ring particles? What is their connection to the ring-moons?*

#### The inner satellites

The small, regular satellites Thebe, Amalthea, Adrastea and Metis, revolve in the inner region of the Jupiter system ranging from  $1.8$  to  $3.1 R_J$ . They are also called 'ring-moons' because they are largely embedded in the Jupiter's ring system. Optical observations by the Galileo spacecraft confirmed that the leading sides of Thebe, Amalthea and Metis are significantly brighter than their corresponding trailing sides (Simonelli et al. 2000). This suggests that one common physical mechanism is governing the global albedo patterns of all three moons. The most plausible mechanism is the impact of macroscopic meteoroids that originated outside the Jovian system (ibid). In recent times, the New Horizons spacecraft has performed a comprehensive search for kilometre-sized moons within the system. No new moons were found, indicating a sharp cut-off in the population of Jovian bodies smaller than 8 kilometre-radius Adrastea (Showalter et al. 2007).

The small inner satellites are interesting in the context of the Jupiter's ring system formation. The Jovian rings contain very little mass, probably much less than the Jovian ring-moonlets, as well as much less than the other outer planets' rings: due to the processes which cause dust migration, to exist nowadays the dusty Jovian ring system must be replenished continuously from a population of parent bodies. In the framework of EJSM, synergistic JEO/JGO investigations will focus on the physical and chemical characterization of Jupiter's small inner moons: global imaging, photometric study and disk-integrated spectra of their surfaces (at least for Thebe and Amalthea) will be carried out in order to confirm them as sources or sinks of the ring particles. Furthermore, these bodies can be periodically observed in order to improve the accuracy of their orbital elements (which may in turn constrain Io's formation region) and of their physical shapes (in order to estimate their bulk densities). Finally, a comprehensive search for new small inner moons with radius < 8 km could be undertaken as well.

**Key questions:** *Are the small inner satellites the source of the material composing Jupiter's rings? What are the compositional similarities and/or differences between these moonlets and the three components of the ring system? To what extent are their surfaces altered by the Jovian environment? Are there other smaller ring-moons revolving in the Jupiter system? Do these moonlets provide clues about the origin of the Galilean satellites (particularly their tidal expansion)? Can the orbits of Thebe and Amalthea constrain Io's region of formation?*

### 2.3.3 Jupiter as a planet

The main goals of JGO for the Jovian atmosphere concern the radiative and hydrodynamic coupling in the Jovian atmosphere, with the two questions: How does Jupiter radiate its internal energy to space? What are the dynamics and coupling in its atmosphere? Three different layers will be sounded to address these questions. In addition, the connection to the interior could be studied with additional payload, through the detection and characterization of internal waves of Jupiter, assumed to link the deep interior with the external layers.

#### 2.3.3.1 *The upper atmosphere*

**The outermost atmosphere layers on Jupiter, its mesosphere, thermosphere and ionosphere, form the interface region between the planet, its magnetosphere and outer space, and their structure and dynamics must be fully characterized.** JGO will address three science topics which are closely linked.

**Firstly**, the thermosphere of Jupiter is much hotter than expected from the solar EUV heating alone (Yelle and Miller, 2004). The energy balance on Jupiter and other gas giants is not yet understood. One candidate source of energy is Jupiter's interior, with energy propagating upward through atmospheric waves. A systematic measurement of waves on Jupiter at low to mid latitudes is required. The results would have implications for all gas giants in our Solar System and the extra-solar systems.

**Secondly**, the dynamics of the thermosphere at low and mid latitudes remain poorly known, even after the JUNO mission. For example, it is unclear whether the zonal jets observed in the stratosphere are present also in the thermosphere and the importance of wave acceleration and ion drag in thermospheric winds is unclear (Miller et al., 2005). The understanding of energy and material redistribution both horizontally and vertically in the upper atmosphere is a major objective of JGO atmospheric structure.

**Thirdly**, a major unknown on Jupiter is its ionosphere, not only its highly variable structure, but also its relation to the H<sub>2</sub> bulge, the key ionization processes, the distribution of ions and the

nature of energy deposition processes. JGO will perform a systematic exploration of total electron densities and study variations of the abundances of  $\text{H}_3^+$ , a key molecule in Jupiter's ionosphere (Drossart et al., 1989). JGO will shed light on the nature of coupling between the thermosphere, ionosphere and magnetosphere of Jupiter at low latitudes. This also has key implications for our understanding of non-thermal atmospheric loss, and thereby of the atmosphere evolution as well as on global magnetospheric currents and dynamics, which ultimately flow through the ionosphere and are linked to the dynamics of the thermosphere.

Key questions: *What is the cause of the thermospheric heating of Jupiter? How is thermospheric circulation organized at low latitudes? What are the key parameters in the coupling between the thermosphere, the ionosphere and the magnetosphere of Jupiter?*

#### 2.3.3.2 *The stratosphere*

**The stratosphere couples the deeper layers of the troposphere to the upper atmosphere and is the region where solar radiation is mainly absorbed.** Its structure, circulation and composition are still poorly determined. Direct determination of winds is not possible in the absence of discrete clouds. However, knowledge of the stratospheric circulation is vital for understanding the transport of hazes and minor species. Temperature fields have been observed by Voyager, Cassini and ground observations which discovered time variations at many different time scales, the longest known being the quasi-quadrannual oscillation. Stratospheric zonal winds can only be inferred from the temperature profiles using the thermal wind equation (except in the equatorial regions), and from the dispersion of dust and chemical elements from the Shoemaker-Levy 9 collision in 1994 (Moreno et al., 2003). Not known, to date, are the meridional and equatorial winds in the stratosphere and their vertical structure. Moreover, the question of the origin of stratospheric water is still open, and has implication on the origin of water in the Solar System: latitudinal variations of  $\text{H}_2\text{O}$  would provide important clues on this origin. Since global circulation in the stratosphere has never been measured directly, wind determination through heterodyne spectroscopic measurements of key constituents in the stratosphere (e.g. in millimetre wavelength) would be a major step forward in our knowledge of the stratosphere of Jupiter.

Key questions: *What is the general circulation in the stratosphere of Jupiter? What is the latitudinal distribution of stratospheric compounds and the origin of the stratospheric  $\text{H}_2\text{O}$ ?*

#### 2.3.3.3 *The troposphere*

**The troposphere will be the deepest level sounded by JGO.** The tropospheric meteorology in a global sense is poorly understood. In particular, the exact origin of the global circulation of Jupiter, the structure of the band system, its relation to differential rotation and the connection of this meteorological system with deep and outer layers are unknown. One way of progressing in this field is to constrain models by direct measurements of the quantities involved in meteorological equations, such as velocities, thermodynamics quantities and the "potential vorticity", which is conserved in non-dissipative flows like a passive tracer, and calculated in numerical models (eg. Read et al., 2006). This latter quantity can be deduced from observations of the wind field, together with temperature profiles of the atmosphere. Moreover, long term monitoring of Jupiter at medium scales (300 km) with potential vorticity retrieval at different time scales would constrain the evolution of waves, of atmospheric structure and of winds from the models. The distribution of lightning storms on Jupiter, detected by Galileo with a non-uniform density, remains mysterious. These convective cells can also be a source of strong gravity waves propagating up to the thermosphere, and contributing to upper atmosphere heating (see section 2.3.3.1).

Finally, internal waves connect the troposphere to the interior of Jupiter and complete the picture that JGO could give of the Jupiter atmosphere from the uppermost layers to the deep interior. The challenging identification of internal modes (seismology of Jupiter) is one of the potential sources of activity observed in the upper layers and their characterization by JGO is one optional goal retained in the science objectives.

Key questions: *How is the tropospheric circulation at cloud level related to the deeper circulation of Jupiter's atmosphere and interior? Are there observable manifestations of a coupling between internal waves on Jupiter and upper atmosphere waves?*

#### 2.3.4 Magnetosphere of Jupiter

The Jovian magnetosphere is driven by the fast rotation of its central spinning object, Jupiter. Its major plasma source is the volcanic moon Io, deep inside the magnetosphere, which releases about 1 ton/s of oxygen and sulphur and feeds with this Io-genic plasma an equatorial magneto-disc extending out over 100s of planetary radii. This system has been compared to stellar binaries and even more exotic objects such as pulsars. The Jovian magnetosphere is the most accessible environment for direct in-situ investigations of processes regarding: (i) the stability and dynamics of magneto-discs, and more generally, angular momentum exchange and dissipation of rotational energy (the '**fast rotator**' theme), (ii) the electro-dynamical coupling between a central body and its satellites (the '**binary system**' theme) including plasma/surface interactions, transport processes and turbulence in partly ionized media. Jupiter is also a powerful **particle accelerator**, its inner magnetosphere being the most severe radiation environment in the Solar System. The various processes that lead to such efficient particle acceleration could also radically affect the 'habitability' on the surfaces of the Jovian moons. Comprehensive and up-to-date reviews of the structure, dynamics and processes in Jupiter's magnetosphere can be found in Khurana et al. (2004) and Krupp et al. (2004). Processes involving the interaction of the satellites with the magnetosphere including the Io plasma torus are reviewed by Kivelson et al. (2004) and Saur et al. (2004).

##### 2.3.4.1 *The magnetosphere as a fast magnetic rotator*

The fast rotation of the planet combined with the continuous supply of ion populations from Io's volcanism lead to the formation of a neutral and ion torus, and further out, of a magneto-disc. Near Io's orbit and at close distances to Jupiter, this plasma torus rigidly co-rotates with Jupiter. Further from Jupiter, the torus thins, and progressively becomes a disc-like system of limited vertical extension, and increasingly departs from co-rotation with growing distance from Jupiter. At typically 50-60  $R_J$  from Jupiter, in the anti-solar direction, the disc transforms into a magneto-tail within which a strong 'planetary' wind blows anti-sunward along open magnetic field lines. The disc rotation is maintained by an electro-dynamical coupling with the Jovian ionosphere: a system of electric currents circulating along the magnetic field lines and closing in the ionosphere transfers angular momentum from Jupiter to the disc. This current system also drives particle acceleration, resulting in auroras and the generation of powerful non-thermal radio emissions. Galileo observations have revealed that these effects are particularly important where co-rotation breaks down, at 15-25  $R_J$ . This simplified axially-symmetric and stationary picture is just a rough approximation. In reality Galileo results have indicated that the magnetodisk properties strongly vary with local time and longitude and are highly time-variable.

Various processes contribute to the radial transport of newly-formed plasma, from the Io torus to the external magnetosphere and to the interplanetary medium: microscopic diffusion, meso-scale interchanges, global sporadic disruptions and reconfigurations of the disk, magnetic

reconnection... All these processes trigger variations in the transport rate of the logenic plasma, in the acceleration of higher-energy particles and therefore in the radial distribution of the ion populations. This modifies locally the rotational stress exerted on the disc, and thus the current needed to enforce the co-rotation. In turn, any modifications in the current system have immediate strong non-linear consequences on the efficiency of the auroral acceleration, the brightness of the aurora, the flux of the radio emissions and, at the end, the visibility of Jupiter at multiple wavelengths. The chain of processes involved in these phenomena, most likely common to any magnetized systems combining fast rotation and radial transport is still not quantified. Their full description and understanding at Jupiter will have immediate implication for other astrophysical disks. Their scales, temporal and spatial, are the fundamental parameters to determine, as they characterize the dynamical processes at work and guide any theoretical or simulation analysis. JGO will investigate the global configuration and dynamical behaviour of Jupiter's magneto-disc along its trajectory inside the system. Simultaneous measurements with JEO and possibly JMO will be particularly important.

Key questions: *What determines the shape and variability of a spinning mass-loaded magnetodisc? What mechanisms control the dissipation of angular momentum and rotational energy? What are the associated transport, acceleration and radiation processes? How do the global magnetospheric structure and activity depend on solar wind effects and mass-loading processes? How do the different electromagnetic emissions diagnose the state of the magnetosphere? How is energy transferred in the coupled thermosphere/ionosphere/magnetosphere system?*

#### 2.3.4.2 *The magnetosphere as a giant accelerator*

A further, largely unresolved problem of a fundamental nature regards the Jovian magnetosphere as a tremendously efficient particle accelerator. There is no question that Io is the primary source of particles in the Jovian environment. The new plasma populations have, however, typical energy of a few 10's eV at best. At what time and spatial scales, and by what mechanisms, are a significant part of them transported through the system reaching MeV energies and populating the harshest radiating environment of the Solar System? The fact that such environments can exist has direct relevance to the notion of 'habitability'. A large and highly variable level of radiation may actually bombard the moons in the system, modifying or controlling the emergence of life. Jupiter is also a 'prototype' of a powerful exo-magnetosphere, possibly powerful enough in radio emissions to be detected at stellar distances. One interesting outcome of in-situ measurements in this radio sources is to determine the highest level of wave energy reachable inside the radio sources and then, to better estimate their possible detection by a very distant observer. The characterization of the high-energy particle population in the Jovian magnetosphere is a key element in understanding astrophysical acceleration processes and its influence on the moons within the system. JGO will investigate the outer radiation belts as well as transport phenomena in the key region of the magnetosphere.

Key questions: *Where do the high energy particles in the Jovian radiation belts come from? How are they produced in the most intense radiation environment in the Solar System? How do they affect moons (their surfaces, tenuous atmospheres/exospheres) and what are the effects in terms of habitability?*

## 2.3.5 Jupiter system

### 2.3.5.1 *Satellite/magnetosphere interactions: the magnetosphere as a magnetized binary system*

Different 'objects' move in the Jovian environment, each of them interacting with the magnetospheric plasma by a large variety of processes. Moons, with their exospheres, are conductive bodies. As they move through the Jovian magnetic field, they create a specific current system (the unipolar dynamo). This electro-dynamical coupling is not stationary. It generates Alfvén wave structures, called 'Alfvén wings', that couple the Jovian ionosphere to the exospheres of moons. This coupling involves dissipation processes that convert electromagnetic energy into kinetic energy of accelerated particles. This is shown in the formation of particular auroral features and, in the Io case, by the generation of non thermal radio emissions.

Io, Europa, Ganymede and Callisto are in complementary situations. The magnetosphere interaction at Io is the most powerful. Io has an extended exosphere, able to fill an environment with matter, and moving in a dense and highly magnetized plasma (the inner Io torus). The coupling with Europa is thought to be less powerful, even if it appears to be able to generate intense waves and a footprint in the auroral region of Jupiter. These two moons, Io and Europa, will be investigated in detail by JEO, while JGO will concentrate on Ganymede and Callisto. Ganymede, the only known magnetized moon, constitutes another unique situation. How this mini-magnetosphere interacts with the giant magnetosphere of Jupiter is a mystery. We only know that this interaction is powerful enough to create an auroral footprint in Jupiter's aurora. In contrast, Callisto, the fourth of Jupiter's Galilean moons, is believed to have the weakest interaction with the surrounding plasma and magnetosphere. Many crucial parameters of satellite/magnetosphere coupling have to date not been measured. The close observation of icy satellites, plasma/surface interactions are key processes to be investigated. This includes processes associated with sputtering of surfaces and exospheres and with resurfacing due to intense bombardments by energetic particles. Given the complex composition of the environment of Jupiter, including Sulphur ions, the understanding of plasma resurfacing is a necessity for the interpretation of the spectral signatures of surfaces. The role played by charged particles in modifying the reflectance of moons' surfaces is not fully understood. It is also clear that energetic ions and electrons are the principal chemical agents in layers close to the surface of moons. However, the actual importance of these effects critically depends on the magnetic environment. All these topics relate to whether a planet immersed in a strong radiation environment can host complex compounds able to react chemically.

**Key questions:** *How does plasma drive material from surfaces and affect surface properties? How do these processes produce and control tenuous atmospheres, exospheres and tori? How do the physical properties of the moons affect their electromagnetic environments? How do the moons and their environments couple to the parent body?*

### 2.3.5.2. Tidal coupling among Jupiter and the Galilean Satellites

The gravitational coupling of the Galilean Satellites and the long-term tidal evolution of the moons has important consequences in the Jovian system (Greenberg 1982; Peale 1986). The characterization of each satellite and Jupiter itself by JEO and JGO in a synergistic and complementary way yield the pieces of information which have to be integrated into the theories of the origin and evolution of the whole system. Europa's habitability including stable conditions for an ocean may be the most outstanding consequence of these coupling processes.

The significance of tides as an internal heat source for the moons and as an important driver for the orbital evolution of the satellites locked in resonance – Io, Europa and Ganymede – has been



recognized since the first Io images obtained by Voyager I. Predicted by theory (Peale et al., 1979) the imaging data of Voyager and later Galileo (Geissler 2003; McEwen et al., 2004) revealed the vigorous volcanism and thermal activity, driven by tidal friction in the moon's silicate layer. The recognition of the importance of tidal forces on geologic and thermal processes as well as the first indirect evidence for a subsurface ocean on Europa was a major outcome of the Galileo mission (Pappalardo et al., 1999; Greeley et al., 2004). It has been suggested that Ganymede's past geologic activity was a consequence of resonance passages and resulting internal heating during the entrance of Ganymede into the three-body resonance (Showman and Malhotra, 1997). However, our current picture of the origin and evolution of the resonance itself, as well as its impact on the individual satellites during their long-term evolution still remains incomplete. From historical and recent data on mutual events of the satellites no consensus on the secular evolution of the satellites could be achieved. Whether the satellites are currently evolving out of resonance or deeper into resonance, as would be revealed by long-term variations of their forced eccentricities) still remains elusive. Furthermore, it is unclear if the satellites are moving inwards to Jupiter due to dominating effects of dissipation in their interior or outwards due to dominating tidal torques exerted by Jupiter (Lieske, 1987; Goldstein and Jacobs, 1995; Aksnes and Franklin, 2001; Lainey and Tobie, 2005).

As revealed by the Cassini-Huygens mission, Saturn's moon Enceladus shows extreme thermal and cryo-volcanic activity (Porco et al., 2006). In this sense Enceladus may be regarded as an analogue to Io in the Saturnian system. Just like Io, Enceladus is locked in a mean motion resonance with another satellite, Dione. The question remains if the activity is continuously ongoing, recent, or episodic. The inherent relation between resonances, tidal heating and thermal evolution of satellites with its important implications for the habitability of icy moons still needs to be understood. These questions will not be addressed by JGO alone but are merely an outcome and synthesis of the entire EJSM, involving both spacecraft and especially the detailed investigation of Ganymede by JGO and of Europa and Io by JEO.

Key questions: *How important is and was tidal heating as an energy source in the Jovian system? Is the origin of the resonance primordial or is it a consequence of tidal evolution later in the satellites' history? Are the activity and possible high dissipative states of the satellites episodic? What role does the Laplace resonance play for the presence and stability of subsurface oceans and the possible habitability of Europa and Ganymede? How do resonance locking, tidal forces and thermal activity interact in outer planet satellite systems?*

## 2.4 Science implementation and measurement requirements for JGO

We now describe our measurement objectives for each of the observation targets identified from our science goals, following their order of appearance in the previous section: Ganymede, the satellite system, Jupiter and finally its magnetosphere. For each target, we describe the measurements to perform with JGO in order to achieve our mission goals. A summary of all these measurement objectives is presented in the form of the Traceability Matrix for JGO. We then describe the additional science to be achieved by synergistic observations between JGO and JEO. Finally, a short summary of the potential contributions of the investigations included in the additional payload is presented.

### 2.4.1 Ganymede

A main goal of JGO is to characterize Ganymede as a planetary body including its potential habitability. Measurements to be implemented by JGO should investigate Ganymede's deep interior, shallow subsurface, surface, and exosphere.

**Presence and location of water on Ganymede:** The detection of a global subsurface water ocean and to infer its basic characteristics requires the combination of two complementary methods: (1) global determination of the induction response to the time-varying rotating magnetosphere of Jupiter at multiple frequencies (Ganymede's orbital as well as Jupiter's rotational period) and (2) measuring the response of the ice shell to tidal forces exerted by Jupiter along Ganymede's slightly eccentric orbit using gravity measurements (Doppler radio tracking) and Laser altimetry (radial accuracy of at least 1m). (2) will determine the dynamical tidal love numbers  $h_2$  and  $k_2$  characterizing the radial displacement and the variation in the gravitational potential due to Ganymede's time-varying tidal bulge. To determine the ice thickness, and the depth and electrical conductivity – thus constraining the amount of salts – of the ocean a combination of the measurements above is required. It will be searched for ocean currents in the induced magnetic signal. Long-term changes in the magnetic field may be detected by comparison with Galileo data. Measurements of the plasma environment and on the intrinsic magnetic field will be required to clearly identify the induced magnetic signal.

To search for local liquid water reservoirs in the shallow subsurface ice, radar sounding up to a depth of 3-4 km (overall dynamic of 50 dB) to resolution of about 10 m will be required. Radar sounding is required for a) obtaining near-subsurface profiles b) subsurface layers reflectivity estimation; c) looking for high reflectivity layers; d) interpretation of the reflectivity profiles in combination with other instruments data to validate the hypothesis of the presence of a water layer. Requirement: nadir pointing accuracy below  $\pm 5^\circ$ , low altitude (200 km) to enhance penetration depth.

**Ganymede's magnetosphere:** Another major goal of the JGO spacecraft is to investigate the unique magnetosphere of Ganymede, the only moon so far which has its own intrinsic magnetic field. The investigation of the key regions and processes between the mini-magnetosphere of the satellite and the giant magnetosphere of Jupiter are very important to better understand this binary system and the entire Jovian system as a whole. The main objectives are: (a) Globally characterize Ganymede's intrinsic magnetic field (to accuracy of 0.1nT). Perform near-surface (100-200 km altitude) global magnetic sounding at spatial resolutions of  $\sim 300$  km (repeat several times to detect variability and to separate intrinsic and induced field) ; (b) Characterize particle population within Ganymede's magnetosphere and its interaction with Jupiter's magnetosphere by measuring the velocity space distribution of thermal plasma with 10 s resolution and by measuring differential directional fluxes of energetic ions and electrons at keV to MeV energies with a 10 s resolution as well as measuring the intensity of local radio and plasma waves vs. frequency; (c) Investigate the generation of Ganymede's aurora (measure the UV emission of Ganymede's aurora); (d) Study of the ionosphere and exosphere of Ganymede in measuring the dust population in the vicinity of Ganymede and its interaction with the Jovian magnetosphere and in measuring the sputtered neutral and charged particle population; (e) Investigate surface composition and structure on open vs. closed field line regions by imaging of Ganymede at FUV-NIR wavelengths at 1km resolution in combination with high resolution magnetic field vector measurements at 1 s resolution. JGO will enable to characterize the dimensions of Ganymede's magnetosphere and well as regions of open/closed field line where particles are either trapped or transported field-aligned between the polar regions of Jupiter and Ganymede along the flux tubes connecting both bodies. During the elliptical orbit phase around Ganymede the spacecraft will go in and out of the small magnetosphere on different local times and latitudes followed by a detailed mapping of the innermost part of Ganymede's environment during the circular orbit phase.

**Geologic features and recent geologic activity:** To study the geologic history of the satellite characterizing the near-surface tectonic and volcanic processes and their relation to interior processes requires global, regional, and local geologic mapping of Ganymede's surface at different levels of resolution and stereo imaging on regional and local scales. From stereo imaging digital terrain models should be derived. Global 4-color maps at 200 m/pix and 4-color coverage for selected large areas, up to 50 m/pix using spectral filters from about 350 nm to 1000 nm are

required to constrain mineralogical/chemical constituents of the near-surface layers and to correlate geologic features with compositional variations. Surface ages will be determined by measuring crater distributions by complete image coverage at 200-500 m/pix resolutions plus sufficient high-resolution target areas (10-50 m/pix) and by monitoring Ganymede's surface on a timescale of the order of hundreds of days up to years to identify newly-formed craters (from comparison with Galileo data).

To identify the dynamical processes that cause internal evolution and near-surface tectonics requires topographic profiles of geologic features e.g. tectonic features, grooved terrain, craters and cryo-volcanic features by Laser altimetry and radar sounding combined with imaging data. The radar will probe the linkage of the ocean to the surface and the dynamics of the near-surface ice-layers, by showing compositional or phase boundaries between different ice sheets and unconformities. The stratigraphic and structural data acquired by the radar will also provide information on crust formation and its consumption matched by the deformational processes. The relation between tectonic features at Ganymede's surface to be investigated by medium and high-resolution imaging, laser altimetry and radar will tell us how ocean, ice and surface interact. The influence of impacts on the ice shell (e.g., high pressure phase transitions) is another important topic to be investigated with radar.

**Composition and physical properties of near-surface layers of Ganymede:** To infer the nature and location of non-ice and organic compounds requires spectroscopic mapping with high spectral and spatial (at least 500 m/pix) resolution in the VIS/NIR and UV. Surface composition and physical characteristics (e.g., grain size) will be correlated with geologic features. It will be searched for spectral signatures of organic compounds in the NIR (3-5 microns) and UV.

Hemispheric differences in composition and physical properties will be characterized to constrain the existence and rate of mass transfer processes. Regolith properties (particle size, composition, distribution, crystallinity) will be studied between a) leading vs. trailing hemispheres (role of impactors and dust); b) north vs. south hemispheres (role of sputtering and amorphization induced by magnetospheric particles).

The composition of Ganymede's exosphere and its relation to surface processes will be studied by multiwavelength (UV-VIS-NIR) characterization and mapping of the abundance at different heights over the surface through limb scans.

**The deep interior of Ganymede:** Doppler radio tracking from low altitude orbit in combination with altimetry data is required to determine satellite's gravity field. The deep interior will be inferred by improved measurements of Ganymede's moment of inertia factor and low-order gravity field coefficients. The assumption of hydrostatic equilibrium will be tested by determination of the static components of the gravitational field coefficients  $J_2$  and  $C_{22}$  from independent orbits (polar) and flybys (equatorial). The gravitational signature of intrinsic density anomalies and regional topographic features will be inferred from the higher-order gravity data in combination with laser altimetry.

The global characteristics of Ganymede, its shape and rotational state and orientation in space should be determined by combining imaging data and laser altimetry. Geodetic networks as reference systems to be derived from these data are required as a basis for other remote sensing measurements.

A detailed study of the intrinsic magnetic field (see above) will constrain the dynamo activity of the core and its implications on the internal dynamics and thermal state of the satellite.

## 2.4.2 Satellite system

### 2.4.2.1 *Callisto*

#### **Interior structure (including the putative subsurface water ocean) of Callisto**

The detection of a global subsurface water ocean and to infer its basic characteristics the combination of two complementary methods will be required: (1) global determination of the induction response to the time-varying rotating magnetosphere of Jupiter at multiple frequencies (Callisto's orbital as well as Jupiter's rotational period) and (2) measuring the response of the ice shell to tidal forces exerted by Jupiter along Callisto's slightly eccentric orbit using gravity measurements (Doppler radio tracking) and Laser altimetry. Laser altimetry will require flybys at an altitude lower than 300 km. To determine the ice thickness, and the depth and electrical conductivity – thus constraining the amount of salts – of the ocean a combination of the measurements above is required.

To search for local liquid water reservoirs in the shallow subsurface ice, radar sounding (overall dynamic of 50 dB) in low altitude flybys to resolution of about 10 m will be required to a) obtain near-subsurface profiles; b) for subsurface layers reflectivity estimation; c) for looking for high reflectivity layers; d) for interpretation of the reflectivity profiles in combination with other instruments data to validate the hypothesis of the presence of a water layer. Requirement: nadir pointing accuracy below  $\pm 5^\circ$ .

Doppler radio tracking from low altitude orbit in combination with altimetry data is required to determine satellite's gravity field. The deep interior will be inferred by improved measurements of Callisto's moment of inertia factor and low-order gravity field coefficients. The assumption of hydrostatic equilibrium will be tested by determination of the static components of the gravitational field coefficients J2 and C22 from independent flybys (inclined and equatorial). The gravitational signature of intrinsic density anomalies and regional topographic features will be inferred from the higher-order gravity data in combination with laser altimetry.

The global characteristics of Callisto, its shape and rotational state and orientation in space should be determined by combining imaging data and laser altimetry. Geodetic networks as reference systems to be derived from these data are required as a basis for other remote sensing measurements.

#### **Composition and physical properties of near-surface layers of Callisto**

To infer the nature and location of non-ice and organic compounds requires spectroscopic mapping with high spectral and spatial (at least 500 m/pix) resolution in the VIS/NIR and UV. Surface composition and physical characteristics (e.g., grain size) will be correlated with geologic features. It will be searched for spectral signatures of organic compounds in the NIR (3-5 microns) and UV.

During Callisto flybys, the cameras and spectrometers (UV-VIS-NIR) will allow a better characterization of the surface regolith properties (particle size, composition, distribution, cristallinity) and of the differences existing between the leading and trailing hemispheres (due to impactors and dust) and the northern and southern hemispheres (ascribed to the effect of sputtering and amorphization induced by magnetospheric particles). In particular, the characterization of the leading/trailing dichotomy can help in constraining the existence and rate of mass transfer processes.

## Callisto's surface geology and interactions with the Jovian environment

To study the geologic history of the satellite requires global, regional, and local geologic mapping of Callisto's surface at different levels of resolution and stereo imaging on regional and local scales. From stereo imaging digital terrain models should be derived. Global 4-color maps at 200 m/pix and 4-color coverage for selected large areas, up to 50 m/pix using spectral filters from about 350 nm to 1000 nm are required to constrain mineralogical/chemical constituents of the near-surface layers and to correlate geologic features with compositional variations. Surface ages will be determined by measuring crater distributions by complete image coverage at 200-500 m/pix resolutions plus sufficient high-resolution target areas (10-50 m/pix) and by monitoring Callisto's surface on a timescale of the order of hundreds of days up to years to identify newly-formed craters (from comparison with Galileo data).

To identify erosional processes (e.g., knobby terrain) and to characterize the degradation of craters requires topographic profiles obtained by Laser altimetry and radar sounding combined with imaging data. The radar will search for compositional or phase boundaries between different ice sheets. The influence of impacts on the ice shell (e.g., high pressure phase transitions) is another important topic to be investigated with radar.

The exosphere of Callisto will be probed during flybys through multi-wavelength (UV-VIS-NIR) limb scan observations, as well as through an INMS if available, in order to improve the characterization of its composition, distribution at different heights over the surface, and evolution in time. An estimation of surface volatiles giving rise to this exosphere will be performed as well.

### 2.4.2.2 *Other satellites*

#### **Investigate the significance of tides for the long-term evolution of the Galilean Satellites:**

JGO and JEO will accurately determine the tidal response of Europa and Ganymede while in orbit around these moons. Additionally, information on Io's thermal state and (if possible) on Io's Love numbers will be obtained (by JEO). The long-term changes of the orbits of the Galilean satellites will be determined by measurements of the positions of the satellites from spacecraft throughout the mission in combination with ground-based observations. Monitoring the satellite positions on the order of ~50m and better whenever possible will help to place bounds on their secular orbital evolution.. Io will be monitored remotely including temporal and spatial variations. Photometric observations will determine its bolometric albedo, at a wide range of longitudes and local times; temporal variations of Io's volcanic and thermal activity will be obtained from limb scans and by imaging Io's night-side.

**Satellite-Magnetosphere Interactions** will be characterized through (a) observations of the moon auroral magnetic footprints by measuring the location and intensity of the footprints in the aurora of Jupiter remotely in combination with in-situ measurements of particles and fields in the field-aligned current systems; (b) the study of pick-up and charge-exchange processes in plasma/neutral tori by investigating the Io and Europa tori with remote and in-situ measurements to better understand the transport phenomena in the inner Jovian system;(c) the analysis of plasma/surface sputtering processes by investigating source and loss processes on the surfaces/exospheres of the moons; (d) analysis of moon micro-signatures to quantify fundamental processes by investigating the critical parameters of particle diffusion in the magnetosphere, corotation velocity of the inner part of the plasma disk and dynamics of the magnetosphere.

**Characterization of satellites' exospheres.** Although the JGO spacecraft is not supposed to orbit inward of Ganymede's orbit, the faint atmospheres of Io and Europa can be anyway monitored, in synergy with JEO, through multiwavelength remote sensing (UV-VIS-NIR) in order to further constrain their composition, distribution over the surface, and evolution in time. An

estimation of surface volatiles supporting the exospheres will be performed as well.

**Physical characterization & chemical composition of outer irregular satellites.** The feasibility of performing a flyby as close as possible with one of the Jupiter's irregular satellites shall be evaluated, for the selected JGO launch option, in order to increase the science return related to the "origins" theme. If a close flyby turns out to be feasible with one of these moons, then a number of measurements is envisaged: satisfactory global imaging to retrieve the global aspect (size, shape) of the satellite and high resolution imaging of selected areas to allow the retrieval of the cratering history; study of the photometric surface behaviour through light curve (in the approach phase) and phase curve (in a wide range of phase angles; the opposition effect can be highlighted by looking at  $<10^\circ$  phase angles); chemical characterization and mapping through multiwavelength (UV-VIS-NIR) imaging spectroscopy; determination of the satellite's mass from radio science tracking; and mapping of the neutral and charged particles sputtered off the surface.

Should a close flyby be not feasible, then some distant remote sensing of one or more irregular satellites, focused on disk-integrated imaging and spectral characterization, can anyway be performed. In this case, long exposures are required to achieve the needed sensitivities and phase angles as low as possible are strongly desired to increase the dayside fraction of the targets. Distant spectroscopy on unresolved targets in principle enables the analysis of compositional correlation between the irregular satellites and some of the major bodies revolving in the Jupiter system (particularly Callisto), while long distant images provided by a NAC also allow to retrieve improved ephemerides for such objects.

**Physical characterization and chemical composition of the ring system, and search for new associated satellites.** Although the JGO spacecraft will never cross or approach the innermost region of the Jupiter system, valuable remote sensing observations can be performed even at the distance of Ganymede. As regards the ring system, investigations will focus on: determination of the structure and particle properties of the Jovian ring system in three dimensions and over different timescales (global imaging of the entire ring system over a range of timescales and in a wide range of phase angles, including  $<10^\circ$  and  $>170^\circ$ ); multiwavelength (UV-VIS-NIR) characterization and mapping of the ring particles composition and photometric behaviour over a wide range of phase angles. Finally, should the JGO payload include also a NAC, the search for new associated satellites (with radius  $< 8$  km) could be undertaken through broad-band visual imaging at low phase angles, using long exposures to achieve the needed sensitivities (however, repeated observations are needed over  $> 1$  year to obtain well-defined orbits).

**Physical characterization and chemical composition of Thebe, Amalthea and possibly other small inner satellites.** From the distance of Ganymede, not only the Jupiter's ring system but also the system of its four small inner satellites (ring-moons) embedded in the ring system can be considered as a valuable target for JGO. In this case, should a NAC be accommodated on the spacecraft, global imaging will be desirable in order to further constrain the satellites' sizes, shapes, and cratering history. The study of their surface photometric and thermophysical parameters through phase curves (in a wide range of phase angles, and anyway looking also at phase angles  $<10^\circ$ ) is a goal to be pursued too. Finally, at least for the largest satellites Thebe and Amalthea, multiwavelength (UV-VIS-NIR), disk-integrated remote sensing will address the chemical characterization of their surfaces, in order to confirm them as sources of the ring particles.

**Determine improved ephemerides for small inner satellites.** The observation of the orbital motion of the small inner satellites with respect to stars also allows to improve the accuracy of the ephemerides of these bodies. In this case, long duration MAC+NAC exposures are needed to achieve the needed sensitivities, and low phase angles are desirable to increase the illuminated fraction of the targets to be framed.

### 2.4.3 Jupiter

Considering the main science objectives described for Jupiter atmosphere, the major science measurements follow, in the context of a post-JUNO mission like JGO. Measurements can be classified according to the three layers of the atmosphere under consideration for JGO. The main guideline for JGO is to put in high priority a wide sampling in the spectral domain, from UV to millimetre waves, at a moderate spatial resolution, in preference to a high spatial resolution monitoring, which will be devoted to JEO in a full complementary way.

**Thermospheric and ionospheric measurements** will be performed from a combination of electronic density measurement, thermal profile retrieval,  $H_2$  and  $H_3^+$  measurement. The first two are measured from radio science experiment, the third from a UVIS spectrometer, and the latter from a VNIR imaging spectrometer in the  $3.5 \mu m$  range. The auroral activity of Jupiter is a high priority objective of the JUNO mission, and is therefore put in lower priority for JGO, but will nevertheless be addressed by VNIR and UVIS instrumentation through  $H_3^+$  and  $H_2$  measurements respectively, as far as the orbit and viewing position permits. The variation in thermospheric temperatures can be sounded through  $H_3^+$  monitoring and radio science thermal profile retrieval; its connection with wave activity, EUV heating and ion drag will be monitored during the mission to address the question of the origin of the thermospheric heating

**The main stratospheric objectives** are the measurement of global winds circulation, of the structure and of the composition of the stratosphere (300 mbars to 1 microbar). Such measurements can be made with a combination of submm sounder, UV and NIR and TIR spectrometer, and radioscience. A heterodyne submm sounder has a unique capability to retrieve stratospheric measurements, through line resolving observations of stratospheric constituents : HCN,  $H_2O$ ,  $CH_4$  are targets for this instrument, which gives also absolute wind measurement, from line profiles, together with thermal profile retrieval. A UV sounder will give access to composition measurements in the stratosphere, aerosol distribution and  $H_2$  emission measurements. Stellar and/or solar occultations with UV sounder and VNIR instrument give vertical sounding of the stratosphere with both structure and composition. From compositional variability (spatial and temporal), the vertical mixing of the stratosphere will be investigated. The measurements must be repeated at a variety of time sampling to address the question of wave activity, including the quasi-quadiennial oscillation of the thermal structure of the stratosphere. Radio occultations over a wide range of latitudes will obtain high vertical resolution temperature structure in the upper troposphere and lower to middle stratosphere, filling in vertical structure information for remote sensing of various latitudes and longitudes. The aerosol component of the stratosphere, an important element for structural and thermal aspects, will be studied through observations in the UV and IR, from nadir and occultation modes.

**In the troposphere** the main objective is to access to potential vorticity measurements, a difficult task in planetary atmospheres: lessons learned from previous mission, scaled to Jupiter observations (Cassini on Saturn, Venus Express on Venus) show that it can be retrieved from a combination of wind measurements (camera and VNIR observations) and thermal profile measurements, as retrieved from a TIR instrument at tropospheric and stratospheric levels. The spatial resolution of these instruments must achieve a 100-300km scale for dynamics measurements, and 300-600 km for temperature. A retrieval as extended as possible on the disk is needed, to constrain the global dynamics of Jupiter at medium scales. The thermal profiles retrieved from radio science helps in calibrating TIR mapper retrievals on specific sites. Composition in the troposphere is a relatively better know subject, and is not put in the highest priority on JGO. It can be retrieved from  $5 \mu m$  window observations by a VNIR spectrometer. At medium resolution ( $\sim 500$ ), main constituents, both condensables ( $H_2O$ ,  $NH_3$ ) and disequilibrium species ( $PH_3$ ) are measurable, when a higher resolution channel ( $> 1000$ ) would give a unique

access to isotopic measurements (N) and other disequilibrium species ( $\text{AsH}_3$ , CO), with higher accuracy retrievals for  $\text{H}_2\text{O}$ ,  $\text{NH}_3$  and  $\text{PH}_3$ , as shown by ground-based measurements from the last two decades.

Finally, the coupling between the different atmospheric layers will be obtained by combining the results from various instruments. The internal structure aspects will be addressed only if additional payload instrumentation is accommodated, to study the Jovian internal oscillations (DSI). Relation of the dynamics with lightning activity is devoted to an additional payload instrument, specialized for these topics (OLD).

#### 2.4.4 Magnetosphere

To meet the main objectives of the mission in terms of magnetospheric science a combination of in-situ particles and fields measurements in combination with remote sensing spectrometers in different wavelength regimes are needed to investigate key region of the Jovian magnetosphere in detail. The magnetospheric payload of JGO will consist of a complementary suite of neutral and charged particles instruments in the energy range eV to MeV, magnetometers, UV- VIS/IR-, and X-ray-spectrometers, radio- and plasma wave receivers, and a dust-detector.

**To characterize the 3D properties of the magnetosdisk** in-situ measurements of the magnetic field vector as well as neutral and charged plasma and energetic particle measurements from eV to MeV with good angular and temporal resolution are necessary. Nearly 3D angular coverage and at least 1 min resolution are wanted to resolve the time scales of the acting processes. In order to better understand the plasma processes in the disk measurements of the radio and plasma waves for various frequencies are needed. Fluctuations of electric and magnetic field measurements in the Hz to MHz regime are necessary. Dust measurements including composition capabilities and charge states complete the investigation.

**To investigate the plasma sources, mass loading variability, composition, transport modes, and loss processes in the magnetosphere** the above mentioned measurements should be completed by measurements of the ionic charge states at 1 min resolution combined with remotely sensed emissions from the Io and Europa tori source regions in the VIS/IR and UV wavelengths and in energetic neutral atoms ENA. Dust stream measurements from Io itself will help to better understand the coupling between dust and magnetospheric plasma at Jupiter.

**The characterization of the magnetosphere/ionosphere/thermosphere coupling processes and the magnetospheric mapping of auroral/radio features** will be performed with in-situ particles and fields measurements at 1 min resolution in the region where the co-rotation of the plasma breaks down and by remote sensing of the auroral regions including the foot prints of the moons and their variability with high resolution in wavelength in UV and IR, X-ray emissions. Radio and plasma wave measurements with high spectral resolution in frequency from the key regions in the magnetosphere are also absolutely necessary in this respect.

**The understanding of the morphology and modulation of auroral/radio emissions and of the modulation of magnetospheric parameters and the magnetospheric response to solar wind variability (Jovian space weather)** is another key objective and will again be measured with the entire magnetospheric instrument package with high spatial and temporal resolution and at multiple wavelengths.

Finally **the characterization of high-energy particle properties, acceleration processes, losses, and the analysis of high-energy electrons synchrotron emissions** from the radiation belts of Jupiter require in-situ measurements of the high-energy charged particle population in the keV to MeV energy range spatially resolved and combined with radio and plasma wave



measurements in the Hz to MHz range. A characterization will also allow determining the bombardment of those particles from the radiation belts onto the surfaces of the moons.

## 2.5 JGO model payload

### 2.5.1 Introduction

The payload complement described in this section was chosen by the JGO Science Definition Team to study the impact of the instruments on the spacecraft resources. The choice of instruments was made to ensure that all kinds of different impacts were studied, ranging from stringent pointing requirements to multiple deployable booms. These instruments are NOT the selected payload suite for this mission. Should this mission be selected for further study, an Announcement of Opportunity (AO) for this mission will be issued for the final selection of the scientific payload.

### 2.5.2 Model payload composition

The definition of the instruments for the model payload was done by the Joint Study Science Definition team, based on the Science Requirements Document [RD 16]. A major goal was to identify the key drivers of the payload towards the spacecraft design, based on a reasonable model payload.

The payload on the Jupiter Ganymede Orbiter shall perform observations during the tour in the Jovian system:

- of Jupiter,
- of Ganymede and Callisto,
- and shall perform Europa and Io observation.

The JGO model payload consists of ten instruments (see Table 2 and section 2.5 for more detail on each instrument) with the mass of 73 kg (without margin). The maximum total power of all instruments adds to 210 W (when operating all instruments at the same time). However in the operational phase not all instruments will be operated at the same time and the peak power at Jupiter will be significantly lower. Additionally to the payload mass of 73 kg the following extra mass must be considered in the S/C budgets:

- 20% margin (~15 kg)
- shielding mass
- mechanisms
- several booms

Instrument	Acronym	Contribution to Science Goals	Characteristics	Mass*	Power
Wide Angle Camera Medium Resolution Camera	WAC + MRC	Global, regional and local surface mapping of Ganymede and Callisto	WAC: framing camera, spectral range: 350-1050 nm, FoV: 117° spatial resolution: 400 m/pix @200 km MRC: pushbroom, spectral range: 350-1050 nm, FoV: 14.7° spatial resolution for stereo: 50 m/pix @ 200 km, Filters: 4-color + panchromatic	7.5	16
Sub millimetre wave sounder	SWI	Characterize the dynamics of stratosphere of Jupiter; Determine vertical profiles of: wind speed and temperature	Spectral range: 550-230 $\mu\text{m}$ , 2 channels FoV: 0.15° – 0.065°	9.7	50
Thermal Mapper	TIR	Characterize dynamics of Jupiter's shallow atmosphere; detect endogenic activity on the satellites	5 – 25 $\mu\text{m}$ , FoV:6.9° 4 narrow filter bands, Resolution (IFOV): 0.5mrad/pixel	5	5
Visible/Near Infrared Hyperspectral imaging spectrometer	VIRHIS	Composition of non-ice components on Ganymede & Callisto; State & crystallinity of surface ices	Pushbroom imaging spectrometer, Spectral range: two channels; 400-2200 & 2000-5200 nm, Spectral resolution: Resolution @500 km: 62-125 m	17	20
Radio Science Experiment	JRST+ USO	Characterize the interior state of Ganymede, presence of a deep ocean and other gravity anomalies	2-way Doppler with Ka-Band transponder including SSPA & USO	3.5	35
Sub-surface Radar	SSR	Probe the structure of the Ganymede subsurface & identify warm ice or anomalies within the ice shell	Single frequency: 20-50 Mhz Dipole antenna length: 10 m tip-to-tip	10	20
Ultraviolet imaging spectrometer	UVIS	Characterize the composition & dynamics of the atmospheres of Ganymede & Callisto	EUUV: 50-110 nm FUV+MUV: 110-320 nm, FOV: 0.1x2° Resolution:> 0.01°	6.5	3
Magnetometer	Mag	Characterize Ganymede's intrinsic magnetic field and its interaction with the Jovian field	Dual tri-axial fluxgate sensors on 3 meter boom	1.5	1.5
Plasma Package	PLP	Characterize the interaction between Ganymede & Callisto and the space environment to constrain induction responses	Thermal plasma number density, Electrons: 1 eV -1 MeV; Ions: 1 eV - 5 MeV, ENA: 1 eV – 100 keV	8.9	30
Micro Laser Altimeter	MLA	Determine amplitude and phase of gravitation tides on Ganymede; global, regional and local topography of Ganymede and Callisto	Single Beam: 1064 nm, 10 m spot	3.6	26
<b>Total</b>				<b>73 kg</b>	<b>207 W</b>
<p><b>*Mass values are excluding margin and shielding; power values are also excluding margins.</b></p> <p><b>Note: SWI and PLP power levels are peak power, SSR mass without antenna &amp; MAG mass without boom</b></p> <p><b>Note: Radio Science experiment power includes power of a SSPA which power (~ 30W) is also already taken into account in the spacecraft telecommunications power budget</b></p> <p><b>Note: UVIS instrument power is average; peak power is expected to be 12 W.</b></p>					

**Table 2: JGO Model Payload summary.**

### 2.5.3 Instrument Description

#### 2.5.3.1 Camera package

The main objective of the camera package is to obtain global coverage of Ganymede and almost global coverage of Callisto in medium resolution as well as high resolution imaging of specific scientifically interesting areas. Secondary goals include imaging of Jupiter, Io and Europa and the small moons. The package consists of the Medium Resolution Camera (MRC) and the Wide Angle Camera (WAC).

##### Medium Resolution Camera (MRC)

The Medium Resolution Camera (MRC) is a nadir looking imaging system including an identical second optical head looking slightly off-nadir to retrieve stereo imaging. The field of view of the camera is  $14.7^\circ$  across track. The imaging sensor is a CMOS detector with  $1024 \times 1024$  pixels, equipped with 4 different colour filters and one panchromatic filter, operated in the push-broom mode. The goals of the MRC include global coverage of Ganymede and Callisto at a resolution of 50 m in stereo and at a resolution of 200 m in 5 colours. The IFOV of the MRC is  $\sim 17$  arcsec and needs a pointing stability of  $\sim 5.6$  arcsec (1/3 of pixel). Each optical head will have its own imaging sensor. The uncompressed data-rate of the camera head towards the data handling system (DHS) is around 5 Mbps. A large compression factor for download to Earth will be needed including the possibility to select data onboard before sending back to Earth. The MRC is a modified version of the Mars Express High Resolution Stereo Camera.

##### Wide Angle Camera (WAC)

The main goal of the Wide Angle Camera is global mapping of Callisto and Ganymede. WAC is nadir pointing and will perform multi-spectral mapping in the wavelength range of 350-1050 nm to discern geological formations and constrain compositional models. WAC has a resolution of 400 m per pixel at an altitude of 200 km and a Field of View (FoV) of  $117^\circ$ . Twelve filters allow for multi-spectral global mapping. The WAC CMOS sensor has  $1024 \times 1024$  pixels (radiation hard to 230 krad) and is the same detector as used in the MRC. The camera will also have radiometric capabilities, relying on known calibration sources, such as particular stars. The camera is a modified version of Mars Express High Resolution Stereo Camera.

#### 2.5.3.2 VIRHIS - Visible and Infrared Hyperspectral Imaging Spectrometer

The goals of the Visible and Infrared Hyperspectral Imaging Spectrometer are to perform geologic mapping of the moons, determine composition of the exosphere of the moons and to study the Jovian atmospheric composition and general circulation. The nadir-pointing instrument has a spectral range of 0.4-5.2  $\mu\text{m}$  with 3.4 degrees FoV. The absolute pointing error allowed is 0.5 arcmin and the required pointing stability is 6.5 arcsec/0.5 sec. The co-alignment mounting knowledge of the instrument needs to be 13 arcsec with respect to the reference optical cube of the spacecraft. The instrument operates in a push-broom mode by using a scanning/pointing mirror internal to the telescope or by using the platform's relative motion with respect to the different targets. VIRHIS is sensitive to a broad spectral range (0.4-5.2  $\mu\text{m}$ ) due to an optical layout using reflecting optics and two HgCdTe detectors: the first devoted to the VIS-NIR range (0.4-2.2  $\mu\text{m}$ ) and the second to the IR range (2.0-5.2  $\mu\text{m}$ ). Both detectors have an active area of  $480 \times 640$  pixels. The heritage of this instrument is from a large range of similar experiments onboard Cassini, Rosetta and Venus Express.

### 2.5.3.3 *Thermal Infrared Mapper*

The main objective of the Thermal Infrared Mapper instrument is to characterize the dynamics and structure of Jupiter's shallow atmosphere (above the cloud level, 300-400 hPa). The second objective is to detect and help understanding endogenic and volcanic activity on the icy satellites. The instrument is a 7.7-21  $\mu\text{m}$  imager using four spectral filters with bandwidths ranging from 600 to 2000 nm and an uncooled bolometer array of  $320 \times 240$  pixels for detection. The design has an IFOV of 0.5 mrad/pixel, which will give 500 km resolution on Jupiter from the orbit of Ganymede and 100 m resolution for orbital observations from 200 km altitude. Filters are placed directly over the bolometer array. The instrument has a relatively low Technology Readiness Level (TRL; see section 8.3) and technology developments are needed to increase the technological maturity.

### 2.5.3.4 *UV spectrometer*

The UV spectrometer instrument will be used to study the Jovian aurora and in the identification of key chemical elements on the surface of Callisto and Ganymede, as well as in the distant monitoring of the Io and Europa tori. The instrument consists of two spectral channels of 50-110 nm (EUV) and 110-320 nm (MUV and FUV). The Field of View of the instrument is  $0.1^\circ$  by  $2^\circ$ . The EUV channel will have a spectral resolution of 0.2 nm and a temporal resolution of a few minutes. The FUV will have a temporal resolution of 1 second and a spectral resolution of 0.5 nm, reaching 2nm in the MUV. The focal plane consists of micro channel plates with position sensitive anode detectors. The instrument design is based on the BepiColombo PHEBUS instrument. The preferred position of the instrument is on a spacecraft corner in order to be able to look at different objects of interest.

### 2.5.3.5 *Micro Laser Altimeter*

The main scientific goal of the laser altimeter is to measure the topography of the moons and as such help to derive digital elevation maps of the surfaces of the moons and to provide essential information for interpretation of the gravity signal. Furthermore the data from the laser altimeter will determine tidal deformation of the moons and help to increase the knowledge of the albedo of the surfaces. In comparison with the conventional design of laser altimeters using high energy low-pulse repetition frequency pulses the new design uses a micro-laser altimeter with low energy pulses with a high repetition rate. The power and mass needed for this instrument are roughly a third of what was needed for a 'classical' laser altimeter. The detector used in this instrument is a silicon avalanche photo diode (SPAD) in a photon counting mode. This detector is capable of detecting single photons with high timing accuracy. The range accuracy of the instrument will be 1 m with a laser footprint of 20 m at an altitude of 200 km. This new design uses a receiver telescope with 10 cm diameter and specific designed pulse detection and analysis electronics. Critical issues with this new design are the laser lifetime and the radiation sensitivity of the detector and electronics.

### 2.5.3.6 *Sub-surface Radar*

The scientific goals of the radar are the identification of the stratigraphic and structural patterns of Ganymede, understanding the crustal behaviour, matching the surface geology with subsurface features and studying the global tectonic setting and Ganymede's geological evolution. The radar has a dipole antenna configuration similar to the Sharad instrument currently flying on the Mars Reconnaissance Orbiter. The two antennas will have a length of 5 meters reaching a tip-to-tip length of 10 meters. It is an active radar sounding experiment with a FoV of  $1 \text{ km} \times 10 \text{ km}$ , a

spectral range between 20 to 50 Mhz. The radar will be able to penetrate the surface up to a depth of 5 km and will have a maximum vertical resolution of 10 m. The Jupiter radiation is an important background noise source for the JGO and will need to be taken into account in the Ganymede radar case to ensure that the radar sounder is capable of achieving an acceptable signal-to-noise ratio.

### 2.5.3.7 Sub-millimetre Wave Sounder

The SWI will provide the possibility to directly measure vertical profiles of winds with scale height resolution from Doppler shifts of molecular species in the Jupiter stratosphere simultaneously with vertical profiles of the temperature. The instrument consists of 2 sub-millimetre heterodyne spectrometers covering the frequency bands around 557 GHz and 1200 GHz. In the instrument baseline subharmonically pumped Schottky mixers and a tuneable solid state local oscillator system are incorporated. Two wide band spectrometers with 1 GHz bandwidth and 100 kHz spectral resolution are required to fulfil the science requirements. The instrument has a high peak power usage of 50 Watts, but with additional technical developments, such as developing more appropriate ASICs this can be substantially reduced to levels between 10-20 W. This instrument has not flown before in this configuration and therefore the TRL is relatively low. A development programme will be needed increase the TRL before the instrument Announcement of Opportunity.

### 2.5.3.8 Plasma Package

The Plasma Package (Table 3) will study the structure and dynamics of Jupiter's fast rotating magnetosphere, and focus on how the Jupiter magnetosphere interacts with the moons and will also be able to detect sources of plasma from the moons inside the magnetosphere. The instrument will also examine the exosphere of the moons in more detail. The Plasma Package is a combination of a number of experiments with which focuses each on a different particles species or energy range.

Sensor	Name	Function
Electron spectrometer	ELS	Electron measurements, 1 eV – 20 keV
Hot plasma spectrometer	HPS	Ion measurements, 1 eV – 10 keV with mass resolution
Medium plasma spectrometer	MPS	Ion measurements, 3 keV – 60 keV with mass resolution
Energetic charge particle spectrometer	EPS	Ion measurements, 3 keV – 5000 keV with mass resolution) Electron measurements, 15 keV – 1000 keV
Dual Langmuir probe	LAP	Thermal plasma number density
Energetic neutrals analyzer	ENA	ENA imaging, 10 eV – 100 keV

**Table 3: Plasma package specification.**

The instrument package also includes a DPU and a scanner unit to give the instruments the capability to observe in wider range of viewing angles. The largest part of the instrument is placed

on the nadir looking face of the S/C. The Langmuir probe will be placed on a boom, integrated with the magnetometer boom or on a dedicated LAP boom in the spacecraft RAM direction.

#### 2.5.3.9 *Magnetometer*

The main scientific goal of the magnetometer is to characterise the intrinsic magnetic field of Ganymede. Furthermore, the magnetometer will characterize the induced fields at Ganymede and Callisto generated in the subsurface oceans. The magnetometers will measure in the bandwidth DC to 64Hz.

The magnetometer consists of two boom mounted sensors. The electronic unit is located on the main equipment platform. Two sensors are needed to facilitate operation as a gradiometer in order to separate the very small target ambient field from any magnetic disturbance created by the spacecraft. The sensors are miniaturised tri-axial fluxgate sensors, with considerable space heritage and high TRL. The ASIC based sensor electronics offers considerable reductions in power consumption with respect to current FPGA based designs and has a predicted radiation tolerance of 300 krad.

#### 2.5.3.10 *Radio Science Package*

The main scientific goal of the radio science package is to investigate the interior of the moons by measuring their static gravity field. It will also help verifying whether the moons have a subsurface ocean by measuring the tidal response of the moons. The Radio Science package will be able to perform atmospheric observations of Jupiter by means of the on-board Ultra Stable Oscillator (USO). The goal of the transponder is to provide a two-way coherent link from/to Earth. The radio science experiment will provide both Doppler and ranging measurements. In particular the ranging measurement can be as accurate as 20-30 cm (two way) using the same transponder technology as for the BepiColombo Ka-band Radio Science payload. For atmospheric science, the Ka-band system can be used in one-way mode, with the on-board USO. The power quoted for the radio science experiment includes 30 W for a solid state power amplifier. The power for this element is also already included in the spacecraft telecommunications power budget. The transponder will have heritage from BepiColombo, while the USO has been flown on Venus Express.

#### 2.5.4 CDF payload composition

For the CDF study [RD 03] a differing payload complement was used than the one described above. After the CDF further maturing of the model payload complement was undertaken by the JSDT to better fulfil all science requirements. The changes with respect to the current model payload are:

- a sub-millimetre wave sounder was included
- a thermal infrared mapper was included
- the Narrow Angel Camera was removed
- the Langmuir probe was removed.

An overview over the payload used for the CDF study is given in the table below (Table 4):

**Table 4: Payload complement used during the initial phase of the CDF study.**

Name	Acronym	Mass [kg]	Power [W]	IDR* [bps]	TRL
Radio Science	JRST+USO	3.0	10.5	5	6
Magnetometers	MAG	0.3	0.6	1	6
Micro Laser altimeter	MLA	3.0	25	60	3
Radar	SSR	12.0	20	220	5
Camera package	WAC+MRC	7.5	16	> 5000	5
V/NIR Imaging spectrometer	VIRHIS	17.0	20	1000	5
EUV-FUV spectrometer	UVIS	6.5	3	4	5
NAC (Narrow Angle Camera)	NAC	8.0	15	5000	5
Langmuir Probe - Plasma wave	LP-PWI	2.6	2	5	8
Plasma Package	PLP	7.7	15.0	25	6
<b>Total</b>		<b>67.6</b>	<b>127.1</b>		

*Note: mass is excluding margin and shielding; power is peak power and excluding margin.*  
 \* IDR=internal data rate





Ganymede		Characterize Ganymede as a planetary object including its potential habitability	
Geology and search for past and present activity	Improve global and regional mapping - a) Imaging with a resolution of 200 m/pxl for at least 50 % of the surface area (One filter / panchromatic filter). b) Mid-res global surface coverage (~ 500 m/pxl) - (One filter / panchromatic filter); c) global surface coverage (~1-2 km/pxl) using four spectral filters from about 350 nm to 1000 nm. d) coherent image mosaics (camera data) at given spatial resolution and viewing angle (not too oblique plus suitable sun elevation - e.g. mid-morning/mid-afternoon). e) Acquire new high res (<10 m/pxl) images of selected areas .	4	
	Topographic mapping of large fractions of the surface. a) obtain profiles using laser altimetry b) derive digital terrain models from stereo imaging (requires imaging of surface area under slightly different angle, but similar sun elevation) c) correlate tectonism on Ganymede with dynamics in the ice shell (obtained by ice penetrating radar)	4	
	Subsurface characterization - a) characterizing the near-surface tectonic and volcanic processes and their relation to interior processes; b) Identify the dynamical processes that cause internal evolution and near-surface tectonics; c) Determine the formation history and three-dimensional characteristics of magmatic, tectonic, and impact landforms.	4	
	Determine global and regional surface ages - a) measure crater distributions by complete image coverage at 200-500 m/pxl resolutions plus sufficient high-resolution target areas (10-50 m/pxl). b) monitor over several years Ganymede's surface in order to identify newly-formed craters. (from comparison with Galileo data). c) study of the impactors characteristics (craters catenae formed by disgregated comets).	3	
	Nature and location of non-ice and organic compounds - a) Mapping spectrometer data with sufficient spectral and spatial (at least 500 m/pxl) resolution in the NIR and UV; b) correlate surface composition and physical characteristics (e.g., grain size) with geologic features, c) Search for spectral signatures of organic compounds in the NIR (3-5 microns) and UV. d) Ion and neutral surface measurements e) Sampling of dust from low orbit and close flyby (<200 km altitude). f) Determine abundances of major elements at surface by X-ray spectroscopy.	3	
	Characterization of hemispheric differences to constrain the existence and rate of mass transfer processes. Determination of the surface regolith properties (particle size, composition, distribution, crystallinity) between a) leading vs trailing hemispheres (role of impactors and dust); b) north vs south hemispheres (role of sputtering and amorphization induced by magnetospheric particles).	3	
	Precise determination of low-degree static gravity field and shape - a) Determination of static J2 and C22 coefficients, b) Test of hydrostaticity; determination of J2 and C22 from independent (polar and equatorial) flybys, c) Determination of degree 2 static topography to at least ten-meter accuracy by laser altimetry and imaging	5	
	Detailed study of the intrinsic magnetic field - (see "Magnetosphere of Ganymede" subsection)	4	
	Search for deviations from hydrostatic equilibrium and for mass anomalies - a) Constraints on non-hydrostatic components from higher harmonics at 10-7 accuracy for the non-dimensional gravitational harmonics. b) High-order gravity sounding to ~300 km horizontal resolution from an altitude of < 200 km.	4	
	Constrain the tidally varying potential and shape - Time dependent altimetry and gravity to determine Love numbers h2 (tidal amplitudes) and k2 (tidal potential). Requires determination of the surface motion that correlates with the eccentricity tidal potential to 1-meter accuracy , and a determination of the time dependent degree-2 gravitational acceleration to 0.1 mgal at Callisto. Alternatively, the eccentricity tidal k2 and h2 at accuracy 0.01. It will determine whether an ocean exists.	3	

Satellite system		Study the Jovian satellite system	
Callisto Study its surface composition, physical properties, putative ocean, and internal structure	Study the induced magnetic field at multiple frequencies - a) Global determination of induction response at multiple frequencies (orbital as well as Jupiter rotation time scales) at Ganymede to an accuracy of 0.1 nT.; b) Looking for secular variation of the 'steady' field or variation in the induction signal since Galileo; c) Magnetotelluric effects from ocean currents. Sensitivity to 0.1 nT.	3	Subsurface characterization - Determine the presence and location of shallow liquid water (including brines).
		4	Composition of the surface - Nature and location of non-ice and organic compounds - a) Mapping spectrometer data with sufficient spectral and spatial (at least 500 m/pxl) resolution in the NIR and UV; b) correlate surface composition and physical characteristics (e.g., grain size) with geologic features, c) Search for spectral signatures of organic compounds in the NIR (3-5 microns) and UV. d) Ion and neutral surface measurements e) Sampling of dust from low orbit and close flyby (< 200 km altitude). e) Determine abundances of major elements at surface by X-ray spectroscopy.
		3	Constrain the amplitude of forced libration and obliquity and non-synchronous rotation - a) Determination of the libration amplitude to 10m accuracy. b) Measure the pole position to determine the obliquity of the spin axis. c) Search for changes in pole position (obliquity) over periods of years (total temporal baseline >1 year and > 3 years strongly desired).
		4	Precise determination of low-degree static gravity field and shape of Callisto - a) Determination of static J2 and C22 coefficients; b) Test of hydrostaticity: determination of J2 and C22 from independent (polar and equatorial) flybys.
		4	Topographic mapping of large fractions of the surface. a) obtain profiles using laser altimetry b) derive digital terrain models from stereo imaging (requires imaging of surface area under slightly different angle, but similar sun elevation) c) study dynamics in the ice shell (obtained by ice penetrating radar)
		3	Characterization of Callisto exosphere - Determine the composition of the Callisto' exospheres. Multiwavelength (UV-VIS-NIR) characterization and mapping of the abundance at different heights over the surface through limb scans.... Determine temperature of surface volatiles that support the exospheres
		3	Characterization of hemispheric differences to constrain the existence and rate of mass transfer processes. Determination of the surface regolith properties (particle size, composition, distribution, crystallinity) between a) leading vs trailing hemispheres (role of impactors and dust); b) north vs south hemispheres (role of sputtering and amorphization induced by magnetospheric particles).
		4	Determine global and regional surface ages - a) measure crater distributions by complete image coverage at 200-500 m/pxl resolutions plus sufficient high-resolution target areas (10-50 m/pxl). b) monitor over several years satellite's surfaces in order to identify newly-formed craters (from comparison with Galileo data). c) study of the impactors characteristics (craters catenae formed by disaggregated comets).
		4	Improve imaging coverage of Callisto's surface - a) Mapping of at least 50 % of the surface (~ 200 m/pxl). b) Global coverage (~ 1-2 km/pxl) with four spectral filters from about 350 nm to about 1000 nm. c) HR images with a resolution of 200 m/pxl for at least 30 % of the surface area. d) Acquire new high res (<10 m/pix) images of selected areas .
		2	Study of pick-up & charge-exchange processes in plasma/neutral tori - a) Remote-sense the radio, UV to VIS/IR emissions from the Io and Europa tori as well as in (high energy) energetic neutral atoms. b) Remote-sense the radio, UV to VIS/IR auroral footprints of Io and Europa

Satellite system		Study the Jovian satellite system	
Io and Europa	Monitor Io's activity at a wide range of longitudes and local times - a) study Io's hemispheric volcanic activity, b) photometry to determine bolometric albedo.	2	
		3	
	Physical characterization & chemical composition of outer irregular satellites (only if a close flyby turns out to be feasible) - a) satisfactory global (for determining size, shape and possible companion bodies) and regional imaging resolution (200-500 m/pxl), b) study of the surface photometric parameters through phase and light curves (looking at zero phase angle desirable) and weathering processes; c) multiwavelength (UV -VIS/NIR - Thermal) characterization and mapping of the surface composition; d) Determination of the satellite's mass from radio science tracking; e) Measure the neutral and charged particles sputtered off the surface.	3	
		2	
Improve our understanding of the irregular satellites	Astrometric observations of irregular satellites - Evaluation of the orbital motion of the satellites with respect to stars (long exposure MAC - NAC images).	2	
	Search for new outer irregular satellites - Search for new satellites by using long exposure MAC images.	2	
	Physical characterization & chemical composition of the ring system & search for new associated satellites - a) determine the structure and particle properties of the Jovian ring system in 3D: global imaging of the entire ring system over a range of timescales and in a wide range of phase angles, b) multi-wavelength (UV-VIS-NIR) characterization and mapping of the ring particles composition and photometric behaviour over a wide range of phase angles, c) search for new associated satellites (with radius < 8 km), d) sampling of dust particles: 3D distribution, and dynamics; investigate dust grain composition and size, e) dynamical interactions between rings and satellites, f) Map the energetic neutral atoms distribution.	3	
	Physical characterization & chemical composition of Thebe, Amalthea and other small inner satellites - a) global imaging to improve the determination of satellites' size, shape and cratering history, b) study of the surface photometric and thermophysical parameters through phase and light curves (looking at low phase angles desirable), c) (at least for Thebe and Amalthea): multiwavelength (UV - VIS-NIR) disk-integrated characterization of the surface composition to confirm them as sources of the ring particles.	3	
Investigate the inner region of the Jupiter system including the ring system	Determine improved ephemerides for small inner satellites - Evaluation of the orbital motion of the satellites with respect to stars (long exposure MAC - NAC images).	1	
	Determination of general circulation & composition in the upper atmosphere from UV and H3+ measurements; characterization of auroral activity from H3+ (IR) and H2 (UV) observations	4	
	Characterization of the vertical coupling in the atmosphere & of its drivers (EUV heating, ion drag or wave activity)	4	
	Temperature structure retrieval from upper atmosphere to the troposphere through radio occultations technique, line profiles in submm range UV and thermal infrared measurements	4	
The upper atmosphere	Characterization of ionospheric total electron densities & variations	3	
	Characterization of the wave activity at low- to mid-latitudes and eddy activity and eddy meridional transport	3	
	Determination of the composition : H2O (characterisation of latitudinal variations, dynamics, role in atmospheric chemistry), HCN (dispersion following the SL9 impact), hydrocarbons (stratospheric chemistry) and haze; characterization of the strength of vertical mixing	5	
	Determination of temperature structure from stellar and solar occultations over a wide range of latitudes in the upper stratosphere (1-km at 20 K per measurement).	4	
Jupiter	Study the Jovian atmosphere		

Magnetosphere	Study the Jovian magnetodisk/magnetosphere	Determination of the general circulation in the stratosphere	4		
		Determination of chemical composition : condensable species (NH <sub>3</sub> , H <sub>2</sub> O) and disequilibrium species (PH <sub>3</sub> , CO) at high spectral resolution (R>1000)	4		
		Characterization of the strength of the vertical coupling in the atmosphere up to the troposphere	4		
		Determination of the composition & vertical structure of clouds and cloud size distribution	3		
		Study of the relation between the upper troposphere circulation & the deep circulation below the clouds & processes driving the jets circulation. Potential vorticity retrieval from combined dynamics and thermal measurements	3		
The troposphere		Constrain the existence and size of a core, and the nature of the H-H <sub>2</sub> phase transition - Monitoring of global oscillation modes of the planet (up to degree l=25 floor, up to degree l=50 desired goal)	1		
		Characterize the 3D properties of the magnetodisk with the help of in-situ measurements of the magnetic field vector, plasma and energetic ions and electrons from eV to MeV at 1 min resolution or better to resolve the acting processes, with nearly 3D coverage in order to obtain good and reliable plasma moments (density, pressure, bulk flow velocity)	3		
		Improve our understanding of the plasma processes acting in the magnetodisk by measuring high frequency fluctuations of electric and magnetic fields from Hz to MHz	2		
The internal structure of Jupiter		Investigate the plasma sources, mass loading variability, composition, transport modes, and loss processes in the magnetosphere with the help a) of in-situ measurements of the magnetic field vector and of charged plasma and neutral energetic particles from eV to MeV with good angular and temporal resolution, with nearly 3D angular coverage; b) of in-situ measurements of plasma and energetic major and minor ion species, including composition capabilities and elemental mass ionic charges at 1 min resolution or better; c) remote radio, UV to VIS/IR measurements of Io and Europa tori emissions as well as in (high-energy) energetic neutral atoms	2		
		Measure dust composition and charge states (including Io dust streams) to better understand the coupling between dust and magnetospheric plasma at Jupiter	3		
		Characterize the large-scale coupling processes between the magnetosphere, ionosphere and thermosphere a) by remote-sensing continuously the jovian radio and auroral emissions in the IR, UV and X-ray wavelengths with high resolution, including the footprints of the moons and their variability; b) improving our understanding of the morphology and modulation of radio auroral emissions by measuring plasma waves and radio emissions vs. frequency with high spectral resolution in frequency from the key regions in the magnetosphere c) determining the magnetospheric mapping of auroral/radio features by measuring in-situ at 1 min resolution the properties of the plasma and energetic ions and electrons in the medium-energy range (100s eV-100s keV) and magnetic field vectors in the region where the corotation breaks-down, in combination with the remote-sensing of the radio and auroral emissions.	3		
		Magnetospheric response to solar wind variability - a) Measure solar wind parameters (magnetic field components, density, bulk velocity, dynamic pressure), b) measure the jovian radio and auroral emissions in the IR, UV, X wavelengths, in combination with in-situ solar wind measurements; c) mapping on a global scale the (high-energy) energetic neutral atoms resulting from charge exchange processes; in combination with in-situ solar wind measurements	2		

Jupiter system		Study the interactions occurring in the jovian system	
		Look for direct evidence of the effects of the solar wind and planetary rotation on driving magnetospheric dynamics, by searching for large-scale changes in the in-situ properties of the plasma, energetic particles, and magnetic field, and by characterizing the spin-periodic modulation of magnetospheric parameters	2
		Characterize the time evolving Jovian radiation environment by measuring in-situ the properties (fluxes, pitch angle distribution) of the charged energetic particle populations (ions and electrons) in the keV to MeV energy range in various regions of the magnetosphere	3
	The magnetosphere as a giant accelerator	Improve our understanding of the particle bombardment of the surfaces of the moons by determining the composition and charge state of the charged energetic particle populations (ions and electrons) in the keV to MeV range in the inner and middle magnetosphere	2
		Detail the particle acceleration processes by measuring the plasma waves and radio emissions vs. frequency in the Hz to MHz range, in combination with in-situ charged energetic particle measurements	3
		Study the loss processes of charged energetic particles by measuring at different energies the time evolving (high-energy) energetic neutral atoms resulting from charge exchange reactions	2
		Measure the time evolving electron synchrotron emissions using ground-based observations in the GHz range, in combination with in-situ measurements of energetic electrons	3
		Observations of the moon auroral magnetic footprints -a) Observe the magnetic footprints in the visible, IR and UV wavelengths	3
	Satellite/magnetosphere interactions: the magnetosphere as a magnetized binary system	Study of pick-up & charge-exchange processes in plasma/neutral tori - a) Measure the low-energy pick-up ion distribution; b) Remote sense the Europa and Io Torus in VIS/IR, UV and using their radio and ENA emissions; c) Measure the energetic particle distributions for ions and electrons; d) Measure the plasma properties of ions and electrons; e) Measure the energetic neutral atom distribution at low energy; f) Measure the magnetic field vector; g) Measure the plasma/radio emissions vs. frequency	2
		Analysis of plasma/surface sputtering processes -a) Measure the neutral and charged particles sputtered off the surface; b) Measure the dust particles (impacting the surface and ejected from the surface)	2
		Analysis of moon micro-signatures to quantify fundamental processes - a) Measure the energetic charged particle absorption signatures; b) Measure the local plasma properties; c) Measure the magnetic field vector	3
	Tidal coupling among Jupiter and the galilean satellites	Determine long-term changes of the orbits of the Galilean satellites - a) accurate positions of the satellites (on the order of a m (desired)) from spacecraft in combination with ground-based observations. b) Imaging of satellites with background starfield. Desired: constrain the secular acceleration of all the moons to $5m/yr^2$ (corresponds to ~a few meters in orbit location).	4
		Study the coupled evolution of Io Europa and Ganymede by determining internal structures, heat flows, and tidal responses of the moons.	5
	Physico-chemistry of the small bodies	Study the composition of the dust particles - a) sampling of dust particles 3D distribution and dynamics; b) investigate dust grain composition and size.	0

## 2.7 Synergies with JEO

The presence of two or more spacecraft simultaneously within the Jupiter system (JGO, JEO and possibly JMO) will allow an unparalleled opportunity for important synergistic science, the type of which cannot be realized with a single spacecraft. The precise details of this science depend on the final mission profiles as well as on the final instrument payloads which will fly; however there are numerous science areas in which such synergies will provide unique opportunities to resolve important unanswered questions including Jupiter science, atmospheres of the Galilean satellites; magnetospheres, geophysics and other satellite science. Below we describe some of the possibilities:

Jupiter: There are two possible areas of synergy between JGO and JEO for the Jovian atmosphere. The first will allow via the two different instrument packages on JGO and JEO for constraints to be placed on conditions in the atmosphere; such as direct characterization from JGO of stratospheric temperature and wind pattern being complemented by cloud level tropospheric information from JEO. If such observations can be performed simultaneously then spatial and temporal changes in the atmosphere will be elucidated. A second synergistic area would be via performing radio occultations of the atmosphere between the two spacecraft. Such spacecraft to spacecraft radio occultations will substantially increase signal to noise as well as remove the perturbing effects of the Earth's atmosphere.

Satellite atmospheres: Simultaneous operation from remote sensing instruments onboard JGO and JEO can potentially enhance spatial and spectral coverage of atmospheric measurements; allow for synergistic observations at different wavelengths; provide greater spatial coverage to resolve atmospheric asymmetries. Combined JGO-JEO observations will enable increased temporal coverage for monitoring of volcanic activity at Io, and shared observations of the very variable Ganymede auroral emissions will better probe the atmospheric and magnetic properties at this moon. Similar dual spacecraft radio occultations such as at Jupiter will help infer atmospheric conditions and plasma interactions. An additional use of the dual spacecraft mode is the ability to respond more readily to discoveries by one of the spacecraft with backup observations possible with the other spacecraft via complementary instrumentation.

Magnetospheres: The strength of simultaneous measurements from two or possibly three spacecraft within the Jovian magnetosphere will enable one to distinguish between temporal and spatial changes. There are four synergistic strategies which if utilized will allow for improved understanding of the structure and dynamics of the magnetosphere. The first application would be to focus on the effect of the solar wind on driving magnetospheric dynamics in which the later arriving spacecraft would monitor solar wind changes driving magnetospheric changes observed by the first spacecraft within the magnetosphere. A second strategy would be to have JEO to monitor Io volcanic activity as well as image Io's torus whilst one or more spacecraft monitor plasma loading processes in the outer magnetosphere. In addition simultaneous long-term stereo imaging of Io's torus will revolutionize our understanding of the 3-D structure and dynamics of the torus. A fourth area of interest is simultaneous two-point observations of Jupiter's magnetotail reconnection processes helping us to understand whether these processes are a global or local phenomenon.

Geophysics: The areas of geophysics which would be addressed by observations from multiple spacecraft include the interior properties of the satellites and rotational and orbital dynamics. This will be of particular interest for Ganymede and Callisto which will have multiple flybys by both JGO and JEO. Multiple spacecraft will result in improved determination of satellite gravity fields via Doppler tracking. Multiple flybys of the moons at different orbital phases may allow measurement of the tidal response and hence possibly constrain internal structure. Multiple observations at the same surface locations will allow accurate determination of the rotational state. Multi-point

magnetic field measurements between JEO and JGO will allow separation of the influence of the Jovian magnetosphere from the influence of Europa and Ganymede; and increased coverage of the various satellites at different phases in the Jupiter magnetic field will allow resolution of the induced response of the moons at multiple periods. The presence of multiple spacecraft will allow, via single beam interferometry, the potential to improve satellite ephemerides.

Other satellite science: Multiple flybys of Callisto by both spacecraft will allow a better understanding of its interior and surface. Initial JEO flybys of Ganymede will help characterize its magnetic and gravitational field and allow optimization of the JGO orbit. Distant observations from JGO of Io and Europa may prove invaluable for enhancing JEO science; such as improving knowledge of the bolometric albedos and thus our understanding of internal heat flow; improving temporal resolution and coverage of Io volcanism and plume dynamics.

## 2.8 Additional Payload and Science that will be gained

The JGO core payload already described allows the main science objectives of the mission to be resolved. However since there may be the possibility of additional payload mass following further mission studies Table 5 lists additional instrumentation shown in order of priority which could be included as part of the payload. The science areas which would gain from such additions are then described.

**Table 5: Prioritised “additional” instrumentation**

Name	Acronym	Mass [kg]	Power [W]
Narrow Angle Camera	NAC	8	15
Doppler Spectro Imager	DSI	4	6
Ion Neutral Mass Spectrometer	INMS	4.9	10
Plasma Wave and Radio Instrument	PWRI	11.2	10
Dust Telescope	JUDO	4	14
Full Plasma Package	PIP-B	13.2	33
Optical Lightning Detector	OLD	3	6
X-ray spectrometer	XITE	2.6	5
<b>Total</b>		<b>50.9</b>	<b>99</b>

The following compressed traceability matrix (Figure 10) shows the additional payload and the science which could be achieved with these instruments.

JGO Themes	Origins	Evolution	Processes	Habitability	SI: Science Investigation	Science Investigation					Core P/L	Core+Add. P/L
						5 Definitely addresses full SI	4 May address full SI	3 Definitely addresses partial SI	2 May address partial SI	1 Touches on SI		
<b>JGO Traceability matrix</b>												
Science Investigation												
Science Objective												
GANYMEDE Characterize Ganymede as a planetary object including its potential habitability	Ice shell and ocean											
	Ganymede's magnetosphere											
	Geology and search for past and present activity											
	Surface composition and physical properties of near-surface layers											
	Deep interior											
SATELLITES SYSTEM Study the Jovian satellite system	Callisto - Study its surface composition, physical properties, putative ocean, and internal structure											
	Io and Europa											
	Improve our understanding of the irregular satellites											
	Investigate the inner region of the Jupiter system including the ring system											
	The upper atmosphere											
JUPITER Study the jovian atmosphere	The stratosphere											
	The troposphere											
	The internal structure of Jupiter											
	The magnetosphere as a fast magnetic rotator											
	The magnetosphere as a giant accelerator											
MAGNETOSPHERE Study the Jovian magnetodisk/magnetosphere	Satellite/magnetosphere interactions: the magnetosphere as a magnetized binary system											
JUPITER SYSTEM Study the interactions occurring in the jovian system	Tidal coupling among Jupiter and the galilean satellites											
	Physico-chemistry of the small bodies											

Figure 10: Compressed raceability matrix.



### 2.8.1 Ganymede and Callisto

A Narrow Angle Camera (NAC) will obtain high resolution images (~ 10m/pxl up to 1m/pxl) at close flybys for selected areas (~1%) at Callisto and in orbit around Ganymede. Erosion processes, regolith properties and geologic features related to recent and present activity will be studied on small scales. In combination with Laser altimetry, radar, and spectroscopy the NAC will characterize how the shallow subsurface and the exosphere and radiation environment interact. It will improve the geodetic measurements of shape and rotation of Ganymede and Callisto and would in orbit allow for determination of librational amplitudes which will contribute to the detection of subsurface oceans. Potential landing sites for future lander missions could be characterized in orbit around Ganymede. Potential hazards for future landed missions on Ganymede can be identified. JGO will never be close to Io and Europa. However, the NAC could be used to monitor these satellites remotely. The resolution of observations of the temporal and spatial variations in Io's volcanic activity and of observations of Europa as well as for the rings and small satellites will be improved. High geometric accuracy and sensitivity will improve astrometric measurements of the satellites. Inclusion of an INMS would allow a detailed determination of the extended atmospheres of both Ganymede and Callisto to be gained. The composition of the atmosphere from sublimation of volatiles and the contribution produced by energetic particle and photon interaction with the surface could be resolved; as well as determining the ion composition of the ionosphere. If geysers and vents are encountered a chemical analysis could be carried out and their temporal evolution mapped. Isotopic analysis will assist in the identification of the chemical and mineralogical nature various surface elements

### 2.8.2 Jupiter's internal structure

A Doppler Spectro Imager (DSI) will perform measurements which enable a study of the global oscillation modes of Jupiter to be carried out. Such modes are of unique interest in order to confirm the existence and size of Jupiter's core, to retrieve the density profile and degree of chemical mixing of Jupiter's interior as well as the distribution of heavy elements. Such observations will complement the gravimetry measurements planned by NASA's JUNO mission. The orbital tour of JGO provides two favourable chances to achieve this goal: the approach phase to Jupiter and the few, initial elongated orbits that will follow the Jupiter orbit insertion.

### 2.8.3 Magnetosphere and aurora

A Plasma Wave and Radio Instrument (PWRI) would enable a detailed investigation of the various moon - magnetosphere interactions to be made. Measurements will determine in situ plasma characteristics in the magnetosphere and measure plasma characteristics and electrical conductivities in the ionized exospheres around the Galilean moons. Electric and magnetic field measurements will characterize waves, energy transfer processes and ULF pulsations. Radio wave measurements add the important remote sensing capability and will determine source locations, polarization, poynting flux of radio emissions from the aurora and the magnetosphere, characterize their variability with time and response to external forcing. This will also help determine Jupiter's magnetosphere /ionosphere/thermosphere coupling processes.

#### 2.8.4 Dust

By analysing the chemical composition of surface ejecta populating the dust clouds around the Galilean moons the Dust Telescope (JUDO) will provide spatially resolved information about the moons surface composition and geology. Since dust grains are charged they can be envisioned as probes for the properties of the Jovian magnetosphere. The charge carried on the dust grains are coupled to the properties of the ambient plasma. Measurements of the electrostatic dust charge simultaneously with the grain size will help to understand the complex interaction between the Jovian dust complex and the plasma environment. The dust observatory will continuously monitor the Jovian dust environment to obtain a comprehensive picture of the life cycle of Jovian dust including the mass transport within the Jovian system.

#### 2.8.5 Jupiter's atmosphere

An X-ray spectrometer (XITE) would allow JGO to map and identify the precipitation of energetic particles, in connection with the H<sub>2</sub> bulge imaged in the UVIS instrument. X-Ray emission from proton bremsstrahlung or K-shell emission of ions in provenance from Io have been identified from Earth Orbit X-ray satellites, but with poor spatial resolution to date. A NAC would give access to a higher spatial resolution (lower than 100km) from Ganymede orbit and would allow JGO to measure smaller scale vorticity, and constrain the meridional transport of vorticity, in connection with JEO. Stereoscopic observations with JEO would also give a unique point of view on the Jovian activity. The importance of thunderstorm, associated with lightning activity, in the dynamics of the Jovian atmosphere has been pointed out from Galileo observations. It has been proposed that convective activity, localized in thunderstorm regions are an important source of vorticity on Jupiter, contributing to the global balance of vorticity responsible of the differential rotation observed at cloud levels. An optical lightning detector would allow JGO to characterize the convective activity of Jupiter, in combination with other core payload instruments.

#### 2.8.6 Science that will be gained.

The gains in science return brought about by this additional payload are significant, as can be visualised from the comparative Traceability Matrix shown below, and they impact all scientific areas of the mission. Considering this, the Phase A study should consider in depth ways and means to increase the total science p/l mass flown on the JGO. Taking the additional p/l on board, or at least part of it, would actually bring JGO closer to the usual instrument mass capability for a spacecraft and mission of its class.

#### References

Aksnes, K. and F.A. Franklin 2001. Secular acceleration of Io derived from mutual satellite events. *Astron. J.* 122, 2734-2739.

Bagenal, F., T.E. Dowling, W.B. McKinnon 2004. Introduction. In *Jupiter: The Planet, Satellites and Magnetosphere*. Bagenal, F., T.E. Dowling, W.B. McKinnon (eds), 1-18, Cambridge University Press 2004.

Blanc, M. and 41 colleagues, Laplace, a mission to Europa and the Jupiter System for ESA's Cosmic Vision programme

- Burns J.A., M.R. Showalter, D.P. Hamilton, P.D. Nicholson, I. de Pater, M.E. Ockert-Bell, and P.C. Thomas 1999. The formation of Jupiter's faint rings. *Science* 284, 1146.
- Canup, R. M. and W.R. Ward 2002. Formation of the Galilean Satellites: Conditions of Accretion. *Astron. J.* 124, 3404-3423.
- Drossart P., and 11 colleagues, 1989. Detection of H<sub>3</sub><sup>+</sup> on Jupiter. *Nature* 340, 539-541.
- Geissler, P. E. 2003. Volcanic activity on Io during the Galileo era. *Annu. Rev Earth. Planet. Sci.* 31, 175-211.
- Goldstein, S.J., jr., and K.C. Jacobs 1995. A recalculation of the secular acceleration of Io. *Astron. J.* 110, 3054-3057.
- Greeley, R., C.F. Chyba, J.W. Head III, T.B. McCord, W.B. McKinnon, R.T. Pappalardo, and P.H. Figueredo 2004. Geology of Europa. In *Jupiter: The Planet, Satellites and Magnetosphere*. Bagenal, F., T.E. Dowling, W.B. McKinnon (eds), 329-362. Cambridge University Press 2004.
- Greenberg, R. 1982. Orbital evolution of the Galilean satellites. In: *Satellites of Jupiter* (D. Morrison, Ed.), 65-92, Univ. Arizona Press, Tucson 1982.
- Kivelson M.G., K.K. Khurana, and M. Volwerk 2002. The permanent and inductive magnetic moments of Ganymede. *Icarus* 157, 507-522.
- Khurana, K.K., M.G. Kivelson, V. M. Vasylunas, N. Krupp, J. Woch, A. Lagg, B.H. Mauk and W.S. Kurth 2004. The configuration of Jupiter's magnetosphere. In *Jupiter: The Planet, Satellites and Magnetosphere*. Bagenal, F., T.E. Dowling, W.B. McKinnon (eds.), 593-616, Cambridge University Press 2004.
- Kivelson, M.G., F. Bagenal, W.S. Kurth, F.M. Neubauer, C. Paranicas, and J. Saur 2004. Magnetospheric interactions with satellites. In *Jupiter: The Planet, Satellites and Magnetosphere*. Bagenal, F., T.E. Dowling, W.B. McKinnon (eds.), 513-536, Cambridge University Press 2004.
- Krupp, N., and 11 colleagues 2004. Dynamics of the Jovian magnetosphere. In *Jupiter: The Planet, Satellites and Magnetosphere*. Bagenal, F., T.E. Dowling, W.B. McKinnon (eds.), 617-638, Cambridge University Press 2004.
- Lainey, V. and G. Tobie 2005. New constraints on Io's and Jupiter's tidal dissipation. *Icarus* 179, 485-489.
- Lieske, J.H. 1987. Galilean Satellite evolution: observational evidence for secular changes in mean motions. *Astron. Astrophys.* 176, 146-158.
- McCord T.B., G.B. Hansen, and C.A. Hibbitts 2001. Hydrated salt minerals on Ganymede's surface: Evidence of an ocean below. *Science* 292, 1523-1525.
- McEwen, A.S., L.P. Keszthelyi, R. Lopes, P.M. Schenk, and J.R. Spencer 2004. The lithosphere and surface of Io. In *Jupiter: The Planet, Satellites and Magnetosphere*. Bagenal, F., T.E. Dowling, W.B. McKinnon (eds.), 307-328, Cambridge University Press 2004.

- Miller, S., A. Aylward, and G. Millward 2005. Giant Planet Ionospheres and Thermospheres: The Importance of Ion-Neutral Coupling. *Space Science Reviews* 116, Issue 1-2, 319-343.
- Moore, J.M., and 11 colleagues 2004. Callisto. In *Jupiter: The Planet, Satellites and Magnetosphere*. Bagenal, F., T.E. Dowling, W.B. McKinnon (eds), 397-426, Cambridge University Press 2004.
- Moore W.B. and G. Schubert 2003. The tidal response of Ganymede and Callisto with and without liquid water oceans. *Icarus* 166 (1): 223-226.
- Moreno R., A. Marten, H.E. Matthews, and Y. Biraud 2003. Long-term evolution of CO, CS and HCN in Jupiter after the impacts of comet SL9 Shoemaker Levy SL9. *Planetary and Space Science* 51, Issue 9-10, 591-611.
- Ockert-Bell M.E., J.A. Burns, I.J. Daubar, P.C. Thomas, J. Veverka, M.J.S. Belton, K.P. Klaasen 1999. The structure of Jupiter's ring system as revealed by the Galileo imaging experiment. *Icarus* 138, 188-213.
- Pappalardo, R.T and 32 colleagues 1999. Does Europa have a subsurface ocean? Evaluation of the geological evidence. *J Geophys. Res.* 104, 24015-24055.
- Pappalardo, R.T., G.C. Collins, J.W. Head III, P. Helfenstein, T.B. McCord, J.M. Moore, L.M. Prockter, P.M. Schenk, and J.R. Spencer 2004. Geology of Ganymede. In *Jupiter: The Planet, Satellites and Magnetosphere*. Bagenal, F., T.E. Dowling, W.B. McKinnon (eds), 363-396. Cambridge University Press 2004.
- Peale, S.J. 1986. Orbital resonances, unusual configurations and exotic rotation states among planetary satellites. In *Satellites* (J.A. Burns, M.S. Matthews eds.), 159-223. Univ. Arizona Press, Tucson 1986.
- Peale, S.J., P. Cassen, and R.T. Reynolds 1979. Melting of Io by tidal dissipation. *Science* 203, 892-894.
- Porco, C.C. and 24 colleagues 2006. Cassini observes the active south pole of Enceladus. *Science* 311, 1393-1401.
- Read P. L., P. J. Gierasch, B.J. Conrath, A. Simon-Miller, T. Fouchet, Y.H. Yamazaki, 2006. Mapping potential-vorticity dynamics on Jupiter. I: Zonal-mean circulation from Cassini and Voyager 1 data. *Quarterly Journal of the Royal Meteorological Society* 132, 1577-1603.
- Saur, J., F.M. Neubauer, J.E.P Connery, P. Zarka, and M.G. Kivelson 2004. Plasma interaction of Io with its plasma torus. In *Jupiter: The Planet, Satellites and Magnetosphere*. Bagenal, F., T.E. Dowling, W.B. McKinnon (eds.), 617-638, Cambridge University Press 2004.
- Schubert, G., J.D. Anderson, T. Spohn, and W.B. McKinnon 2004. Interior composition, structure and dynamics of the Galilean Satellites. In *Jupiter: The Planet, Satellites and Magnetosphere*. Bagenal, F., T.E. Dowling, W.B. McKinnon (eds), 281-306, Cambridge University Press 2004.
- Showalter M.R., J.A. Burns, J.N. Cuzzi, J.B. Pollack 1987. Jupiter's ring system - New results on structure and particle properties. *Icarus* 69, 458-498.

Showalter M.R., A.F. Cheng, H.A. Weaver, A.S. Stern, J.R. Spencer, H.B. Throop, E.M. Birath, D. Rose, and J.M. Moore 2007. Clump detections and limits on moons in Jupiter's ring system. *Science* 318, 232.

Showman, A.P. and R. Malhotra 1997. Tidal evolution into the Laplace resonance and the resurfacing of Ganymede. *Icarus* 127, 93-111.

Simonelli D.P., L. Rossier, P.C. Thomas, J. Veverka, J.A. Burns, and M. Belton 2000. Leading/Trailing albedo asymmetries of Thebe, Amalthea, and Metis. *Icarus* 147, 353-365.

Yelle, R.V. and S. Miller 2004. Jupiter's thermosphere and ionosphere. In *Jupiter: The Planet, Satellites and Magnetosphere*. Bagenal, F., T.E. Dowling, W.B. McKinnon (eds), 185-218, Cambridge University Press 2004.

Zimmer, C., K.K. Khurana, and M.G. Kivelson 2000. Subsurface oceans on Europa and Callisto: constraints from Galileo magnetometer observations. *Icarus* 147, 329-347.

## 3 MISSION PROFILE

### 3.1 Mission Architecture

To explore the Jupiter system in detail, two spacecraft are planned: the ESA Jupiter Ganymede Orbiter (JGO) and the NASA Jupiter Europa Orbiter (JEO) (see section 1.2). Both would examine the whole Jovian system, with JGO focussing on the outer two Galilean satellites (Callisto and Ganymede) and the JEO focussing on the inner two (Io and Europa). Both spacecraft would explore the system for ~2.8 years and examine the magnetosphere, rings and atmosphere of Jupiter, as well as the rocky and icy Galilean moons. JEO would eventually be placed in orbit around Europa and JGO would eventually be placed in orbit around Ganymede.

JEO would be launched by NASA and JGO by ESA in early 2020. Both spacecraft would use chemical propulsion and Venus and Earth gravity assists to arrive at Jupiter approximately 6 years later. After insertion into Jupiter orbit, JGO would perform a tour of the Jupiter system using gravity assists of the major moons to change the trajectory in order to perform science measurements. JGO uses Ganymede gravity assist to inject into an initial  $13 \times 245 R_J$  highly elliptical Jupiter orbit, thereby avoiding the main radiation belts of Jupiter.

During the tour through the Jupiter system, the instruments onboard would observe Jupiter and perform measurements in its magnetosphere. The JGO model payload complement includes 10 instrument packages (see section 2.5). JGO moves into a resonant orbit with Callisto to perform remote sensing observations during 19 fly-bys. After more than 1 year in resonant orbit with Callisto, JGO is transferred to Ganymede and inserted into an elliptical polar orbit (200 km x 6000 km) above the surface of the moon, remaining there for around 80 days, performing amongst other observations measurements in the Ganymede magnetosphere. Afterwards, JGO transfers to a 200 km near-polar circular orbit for close-by observations of Ganymede with duration of around 180 days (the duration is limited by the gained total radiation dose (design goal <100krad) and the orbit stability). The mission would end with a propulsive manoeuvre to force an impact onto Ganymede.

### 3.2 Key Challenges and mission driver

The main challenges of designing the Jupiter Ganymede Orbiter are:

- **Jupiter's radiation environment.** Although the amount of radiation at Ganymede and Callisto is far less than at inner moons Europa and Io, it is not negligible. It is crucial for the feasibility of JGO to limit the total radiation dose acquired during the mission and also understand the availability of radiation hard/ radiation tolerant components for the spacecraft, subsystems, and the instruments. Shielding with 8 mm (Al-equivalent) keeps the overall total ionising dose (TID) below 100 krad for the total mission.
- **Low solar power of at Jupiter.** At Jupiter's distance from the Sun, the solar flux is  $51 \text{ W/m}^2$ . The baseline concept for JGO power conversion is the use of GaAs low intensity low temperature (LILT) solar cell arrays with a total surface of  $51 \text{ m}^2$  (note: Rosetta has  $68 \text{ m}^2$ ). The end-of-life performance and degradation of the performance are taken into account. No solar concentrators for the solar array are foreseen.

- **Communications.** JGO is at a maximum distance of ~6.1 AU from Earth after arrival in the Jovian system. This is a clear driver for the onboard telecommunications system and power system.
- **Payload accommodation.** Mainly payload power, pointing requirements, accommodation of various booms, electro-magnetic cleanliness (EMC) requirements and thermal requirements are main driver for the S/C design.
- **Thermal.** The high temperature close to Venus (due to the required gravity assist) is in strong contrast to the low environmental temperature at Jupiter, hence driving the thermal system design.
- **Navigation and operations.** JGO performs several gravity assist and an extended tour through the Jovial system with several close fly-bys (at around 200 km), hence driving the overall operations of the mission.

### 3.3 Performed Major Mission Profile Trades

During the CDF study [RD 03] five major trade-off areas were analysed in order to select the baseline mission profile for JGO, including launcher selection, payload complement, staging options, transfer options, and passenger S/C option.

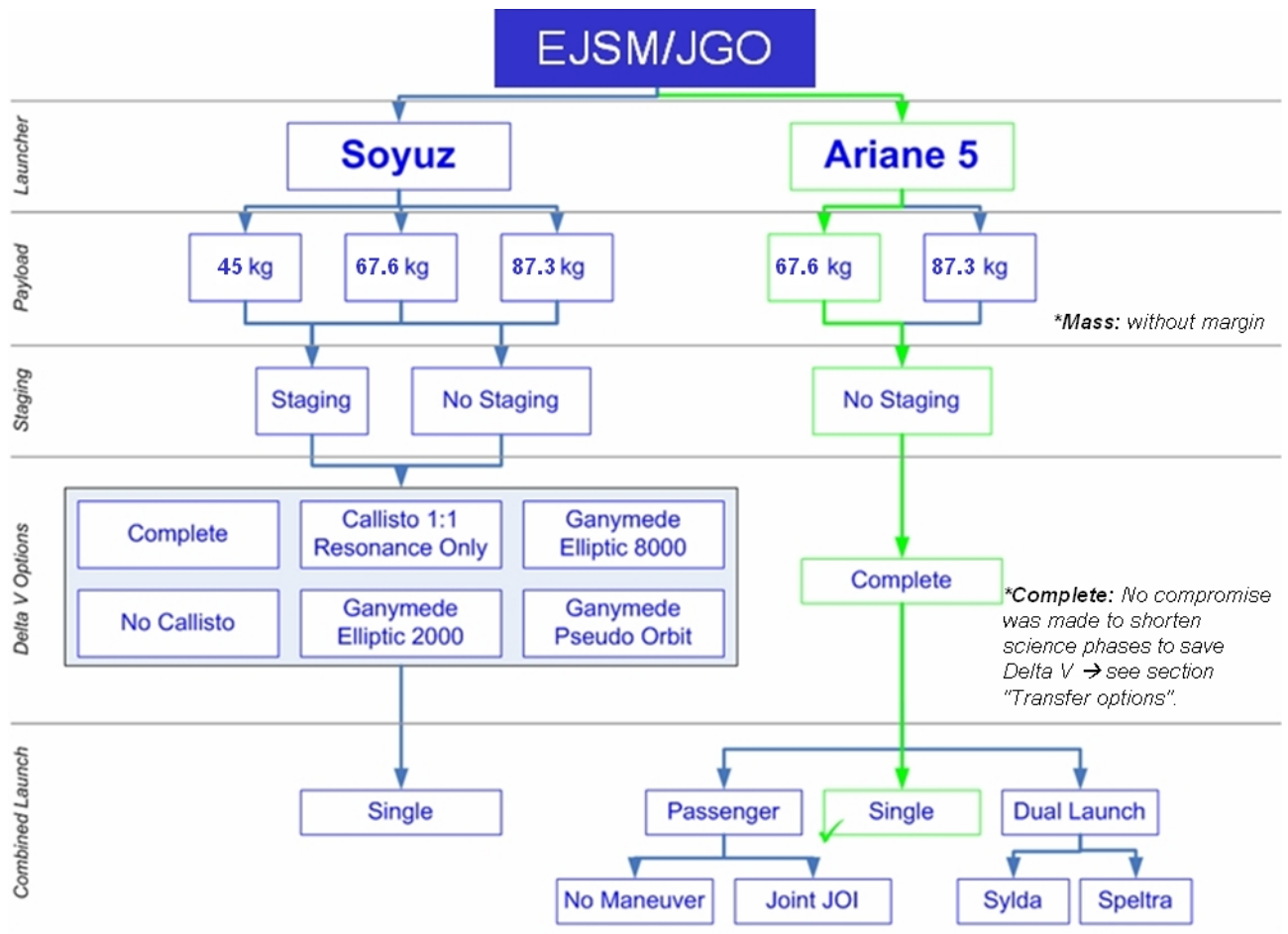

Figure 11: System trade-offs.

### 3.3.1 Launcher

The two launchers considered were the Soyuz-Fregat 2-1b and Ariane 5 ECA, both launched from the Kourou Ground Station (CSG). The Soyuz option was considered initially for the EJSM/JGO mission because of its lower cost.

The Soyuz can launch a total mass of 3170 kg (including launch adapter) into GTO [RD 13]). In comparison, Ariane 5 can launch a mass of 4362 kg (including launch adapter) directly into an interplanetary trajectory, hence requiring JGO to perform 1480 m/s  $\Delta V$  less, than for a Soyuz mission.

Further analysis has shown that the Soyuz launch does not lead to a feasible JGO scenario and hence has been discarded.

### 3.3.2 Model payload

Three model payload complements, with masses of 45 kg, 68 kg and 87 kg have been considered in the CDF study, as sizing cases. Table 6 shows which instruments were included in each package.



**Table 6: Three model instrument package sizing cases used in the CDF study.**

Instrument	Acronym	45 kg	68 kg	87 kg
Radio science	JRST+USO	✓	✓	✓
Magnetometer (Option 2)	MAG	✓	✓	✓
Micro Laser Altimeter	MLA	✓	✓	✓
Medium Resolution Camera	MRC	✓	✓	✓
Wide Angle Camera	WAC		✓	✓
UV Imaging Spectrometer	UVIS	✓	✓	✓
V/NIR Imaging Spectrometer	VIRHIS	✓	✓	✓
Langmuir Probe - Plasma Wave	LP-PWI	✓	✓	✓
Plasma Package	PLP	✓	✓	✓
Radar	SSR		✓	✓
High Resolution Camera	HRC		✓	✓
TIR Imaging Spectrometer	TM			✓
Doppler Spectrographic Imager	DSI			✓
Sub-mm Wave Sounder	SWI			✓

The ~68 kg instrument complement was adopted for sizing purpose for the CDF study, since it was assumed to provide good science return for a reasonable total mass.

### 3.3.3 Staging

For the Soyuz case a separate Propulsion Module (PM) for JGO was investigated, with the aim to provide the  $\Delta V$  required for the escape manoeuvre (1480 m/s) and launch vehicle dispersion errors (178 m/s). The PM would then be discarded and the remaining manoeuvres would be performed by JGO on board propulsion system. As the Soyuz case has been discarded this option is not further described here.

### 3.3.4 Transfer Options

As the Soyuz did not lead to a feasible mission baseline, several  $\Delta V$  saving options were analysed to implement an acceptable mission with Soyuz:

- **Callisto 1:1 resonant orbits only:** saves marginal  $\Delta V$ , but loses global coverage of Callisto.
- **Removal of the Callisto science phase:** this saves at least 152 m/s of deterministic  $\Delta V$  and 30 krad of radiation dose, but limits science return from Callisto.
- **Removal of the Ganymede circular phase:** saves 435 m/s and 34 krad of radiation dose, but would severely limit science return.
- **Higher apocenter during the Ganymede elliptic phase:** save marginal  $\Delta V$ , but would strongly affect the orbit lifetime, as the orbit would decay very quickly.
- **Implement Ganymede resonant orbit:** net savings of 750 m/s in  $\Delta V$ , but would lose global coverage of Ganymede.

For all these  $\Delta V$  saving options, the Soyuz launch performance was still insufficient, and additionally the science return of the mission severely reduced, hence these were concluded as non-viable options.

### 3.3.5 Combined Launch

The Ariane 5 launch vehicle provides a comfortable mass margin for the JGO mission. Two options were analysed to increase the science return with a passenger spacecraft being launched together with JGO

- (a) **Passenger** directly attached to JGO carried and inserted to Jupiter centric orbit by JGO.
- (b) **Dual Launch**: launching the passenger spacecraft together with JGO with an Ariane 5 dual launch adapter, and no direct interface to JGO.

The analysis lead to following conclusions: in case (a) additional required interfaces, structural strengthening and increase of propellant on JGO would exceed the available mass and would have a severe impact on the configuration of JGO (e.g. accommodation of the high gain antenna).

Case (b) would allow for an unmodified JGO design, but the additional launch adapter structure mass would take up most of the remaining excess mass, leaving not enough mass for the passenger.

**In conclusion a combined launch is regarded as not desirable and the excess mass is kept as solid mission margin.**

### 3.3.6 Summary on the Major CDF Trade Results

The result of the trade study, as shown in Figure 11, defined the baseline mission design for JGO:

- Launch with Ariane 5 from CSG (ESA's Guyana Space centre)
- 67.6 kg P/L package (without margin, booms and shielding). Note that the model payload changed (see 2.5.2).
- No staging
- Complete mission scenario (no compromises on the science orbits)
- Single launch
- Ariane 5 adapter mass.

## 3.4 Mission Environment

Jupiter's strong magnetic field is a natural accelerator of particles. As a consequence, the energy and fluxes of trapped particles (electrons, protons, ions) inside the Jovian magnetosphere are much higher than those at Earth or in any other planetary environment. The trapped particles populate the radiation belts of Jupiter, which make Jupiter missions very challenging. The greatest threat to spacecraft systems are the charged particles in the hundreds of keV to tens of MeV energy range. Electrons are the hardest to shield and this implies including a significant mass for shielding material on the spacecraft.

JGO would spend a large portion of the mission at great Jupiter distances (in the vicinity of Callisto (at  $\sim 26R_J$ ) and Ganymede (at  $\sim 15R_J$ )). Hence it is important that the radiation analysis model contain accurate information in the range of 15 to 30  $R_J$ . Whereas the most intense belts are encountered below 10  $R_J$ , the particles fluxes drop significantly beyond 16  $R_J$ . Therefore, it is mainly the time spent by the spacecraft within 16  $R_J$  (i.e. in the vicinity of Ganymede) that would give the highest contribution to the total radiation dose.

### 3.4.1 Radiation models overview

Jovian electron and proton radiation belts have been modelled empirically (D&G83 [RD 04], GIRE [RD 05]) and physically (Salammbô [RD 06], [RD 07]) by various groups in the United States (Jet Propulsion Laboratory, South-West Research Institute) and in Europe (ONERA), whereas the ion radiation belts have attracted so far less consideration [RD 14]. These models are based on different approaches, different input parameters (spacecraft data, magnetic field models), and have different spatial and energy coverage. They are described briefly here:

- **D&G83:** The Divine-Garrett model [RD 04]. This is the oldest model. It was developed in 1983 based on in-situ measurements made by the Pioneer and Voyager spacecraft. It is the most complete of the models. It covers both electrons and protons, and the complete range in energy and radial distance (see Figure 12 and Figure 13).
- The **GIRE** model [RD 05]. Since 1995 the GIRE (Galileo Interim Radiation Environment) model has been developed. This incorporates the new data obtained by the Galileo mission in addition to the data used in the old Divine-Garrett model. However, the GIRE model still only has a limited coverage; in particular, it only covers electrons at a radial distance between 8 and 16  $R_J$ .
- **Salammbô-3D** model [RD 06], [RD 07]. Since 1998 the Salammbô-3D model has been developed by ONERA. This is a theoretical model based on knowledge of the Earth's radiation belts. It covers both electrons and protons, but only for small radial distance (up to 9.5  $R_J$  for electrons and up to 6  $R_J$  for protons), which is not large enough for the mission. It should be noted that specifically the predicted proton fluxes for Salammbô-3D are much higher than the ones predicted by the Divine-Garrett model.

The spatial and spectral coverage of the original Divine & Garrett model, the GIRE and the new Jupiter Salammbô model are given in Figure 12 and Figure 13.

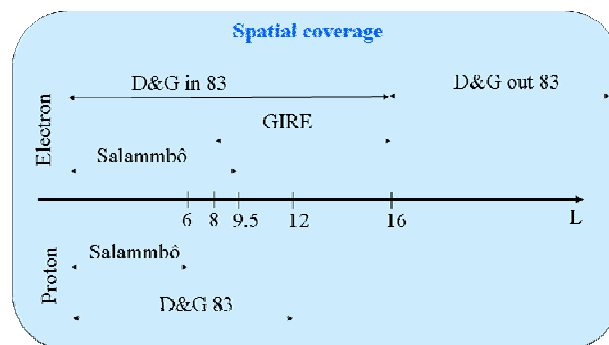

Figure 12: Spatial coverage for the different Jovian radiation belt models.

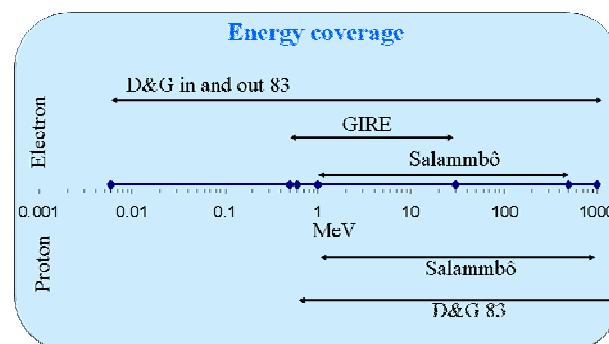

Figure 13: Energy coverage for the different Jovian radiation belt models.

The horizontal scale in Figure 12 is defined as the magnetic shell parameter  $L$ , which can be regarded as the distance from Jupiter based on the magnetic field model. It corresponds closely to the actual distance from Jupiter. The Salammbô model is valid for ranges up to the orbit of Europa ( $R_J=9.4$ ) for electrons and up to the orbit of Io ( $R_J=6$ ) for protons.

In Figure 13 the spectral ranges of the three models are given and it is clear they cover more or less the same spectral range for protons, while for electrons the D&G model also takes into account the low energy electrons ( $< 1$  MeV).

One critical feature is that the more sophisticated model of Salammbô yields far higher fluencies of protons inside Io's orbit than the D&G model. The Salammbô model is in better accordance with the actual data taken by the Galileo probe.

The end results of these models were used to constrain potential mission scenarios and estimate the mission Total Ionizing Dose (TID) received by a spacecraft during its lifetime, given its trajectory through the environment. During the assessment phase of JGO, ESA's approach consisted of taking advantage of all these models (D&G83, GIRE, and Salammbô) by combining them together. In the resulting JOP/JOE model provided by ONERA [RD 09], the selection from one model to the other is done first according to radial distance, then according to energy level. Since JGO would always orbit beyond  $12 R_J$  the only relevant models in term of spatial coverage are the D&G83 and GIRE models. The D&G83 model imposes the most stringent constraints in terms of radiation doses and corresponds approximately to the worst case in the GIRE statistical model.

Additionally the assumed radiation levels at Ganymede are overestimated because no shielding effects of the moon (given by its mass and the intrinsic magnetic field) were taken into account. This aspect is currently under investigation.

Work has been done to merge the 3 mentioned models in a single tool [RD 09], which is applied here for the total dose calculation. The worst case of the 3 models has been assumed within this new tool.

#### 3.4.2 Total dose calculation

The **radiation dose rate** which can be expected for the EJSM/JGO mission, excluding the interplanetary transfer phase, is shown in Figure 14.

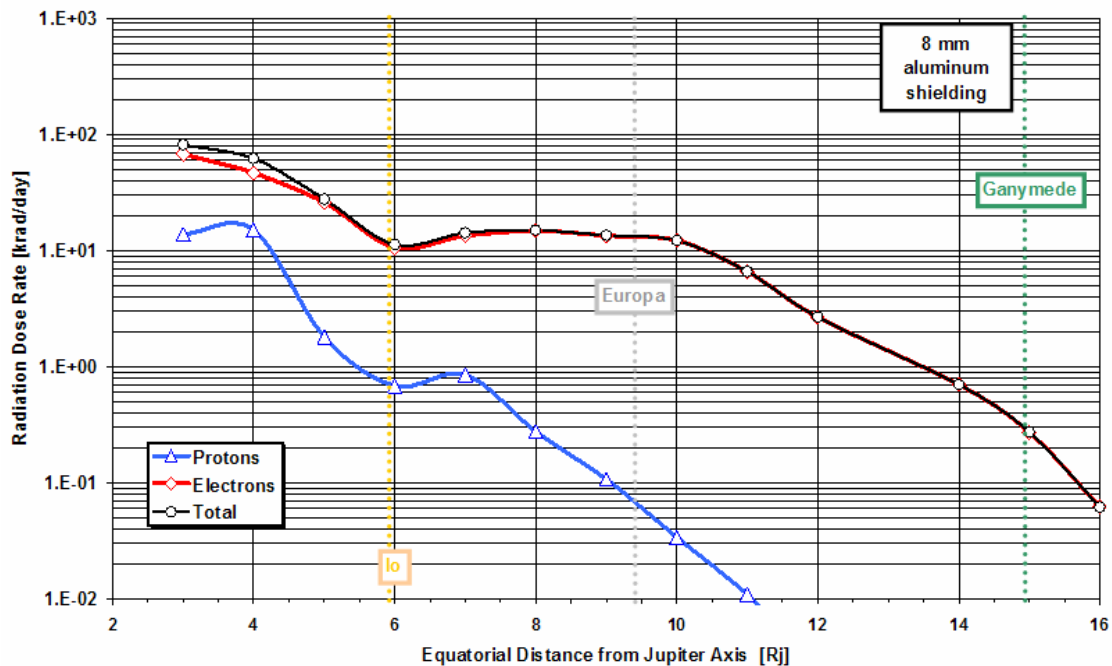

**Figure 14: Calculated radiation dose rate in krad/day versus equatorial distance from the Jupiter axis in Jovian radii ( $R_J$ ).**

Based on the JGO trajectory derived for the new 2020 launch date and environment models described above, the radiation analysis for each mission phase (see section 4.2, Table 8) was updated and the results for the JGO baseline mission are shown in Table 7. It is evident that the highest TID is accumulated during the science phase of the circular orbit around Ganymede.

The following assumptions were made:

- Dose measured behind 8 mm aluminium shielding
- Dose independent of inclination
- The radiation figures are shown without margin. The uncertainty of the radiation models is currently quite high and therefore a radiation margin of up to 100% should be taken into account. This will be analyzed in more detail in a later stage of the study.

Phase	8mm Al [krad]
Cruise	-
Jupiter to GGA2	1
GGA2 to GGA6	5
GGA6 to Callisto	8
Callisto science	21
Callisto to Ganymede	2
Ganymede science (elliptical)	15
Ganymede science (circular)	33
<b>Total</b>	<b>85</b>

**Table 7: Total ionising dose calculation behind 8mm Al shielding.**

### 3.4.3 Shielding mass analysis

A shielding mass analysis was performed to calculate a realistic shielding mass for the 67.6 kg model P/L of the CDF study. The following assumptions were made:

- All instruments are represented by boxes which are surrounded by a shielding layer of Aluminium. The thickness of this layer was in most cases 8mm. In a few cases, where components were more susceptible to radiation damage, a thickness of 9mm was assumed.
- The relative positioning of boxes and thus their accumulated shielding effect was not taken into account. For this analysis ray tracing would have been required.
- The potential shielding effects of the S/C primary structure were not considered.

**This analysis resulted in a shielding mass of ~80 kg for P/L and spacecraft avionics for the 67.7 kg payload considered in the CDF study, which was consequently allocated in the spacecraft mass budget.**

Either a reduction of the required shielding mass, or a reduction of TID requirements to spacecraft and payload components by means of the following **mitigation strategies is possible**:

- Selection of tailored shielding material could gain a reduction by a factor 2, when the environment is dominated by electrons (cf. the JURA CDF [RD 03]).
- During the circular orbit around Ganymede, the shielding effect provided by Ganymede would reduce the dose by a factor 3 or more (tbc) while the spacecraft is on the far side. An analysis and quantification of this effect is summarized in the following section (3.4.4).

### 3.4.4 Refinement of radiation model at Ganymede

The use of the JOP/JOE model [RD 06] indicated that JGO would accumulate the highest TID during the phase when it would orbit Ganymede for months (see Table 7). However, such a model is not appropriate to estimate the dose in orbit around any of the Jovian moons (and, hence, Ganymede), since it does not take into account the local radiation environment of the moons, which differs significantly from the Jovian radiation environment. Since JGO would be in orbit around Ganymede for months, this correction to the TID is important as JGO would spend a considerable amount of time within 16  $R_J$  in orbit around Ganymede.

Jovian moons are shielding a spacecraft from charged particles and therefore a significant reduction of the received total dose can be expected. At Ganymede, the dominant shielding processes are much different from those at Europa [RD 10], because of the influence of Ganymede's intrinsic magnetic field. During its orbital phase around Ganymede JGO would encounter different magnetic field lines topologies, and, hence, different radiation doses.

Outside Ganymede's magnetosphere, Jovian field lines (see Figure 15, left image) are connected to Jupiter's ionosphere at both ends. Within Ganymede's magnetosphere, closed field lines connected to Ganymede at both ends and 'open' field lines connected to Ganymede at only one end and to Jupiter at the other end are encountered.

At Ganymede (see Figure 15, right image), charged particles have less access to closed field lines and can only stay trapped for some pitch angles. On 'open' field lines, large loss cones develop and the moon's magnetic field influences trapped populations.

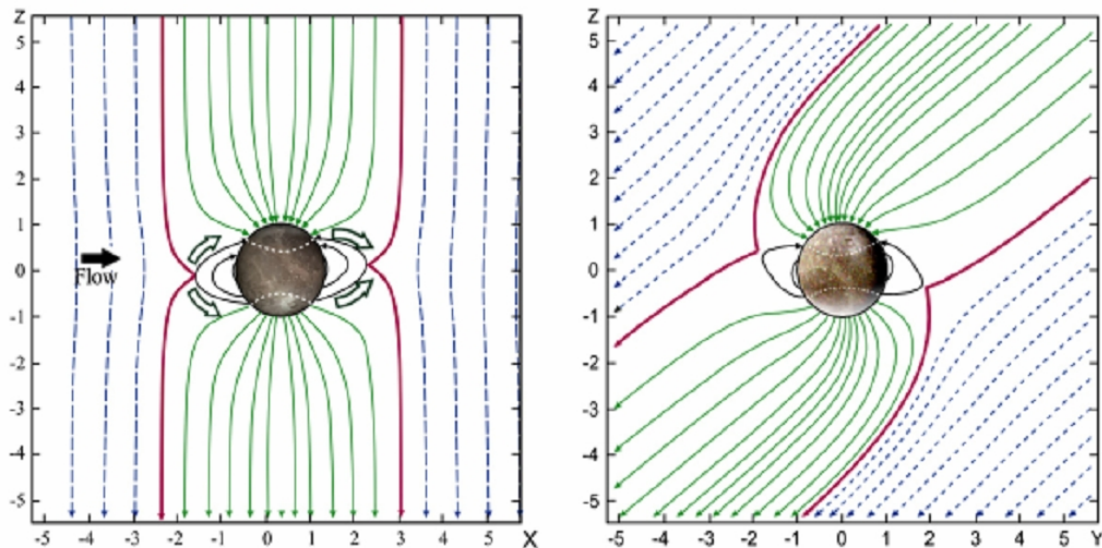

**Figure 15: The three types of magnetic field lines encountered in the vicinity of Ganymede [RD 15]. Blue lines: Jovian field lines; green lines: open field lines; black lines: closed field lines.**

The current estimate of the precipitating intensity of these electrons is about **12%** of the value away from Ganymede. This preliminary estimate [RD 11] is likely to represent the dose reduction during the very last phase when JGO would be in circular low-altitude polar orbit around Ganymede, but a proper calculation should be made for all electron energies [RD 12]. Currently there is no quantitative estimate for the dose reduction during the phase when JGO would be in elliptical orbit around the moon. But Galileo observations have always shown that the dose is significantly reduced in Ganymede's magnetosphere compared to in the Jovian environment. **In summary, Ganymede provides a natural and efficient shielding to JGO during the Ganymede science phase.** Nevertheless for this report quoted total dose estimates for JGO are excluding this shielding effect.

### 3.5 Planetary protection

This mission would currently be classified as category II under COSPAR (see section 8.2). Therefore, standard processes for cleaning [RD 19] are acceptable and no sterilization is required. However, it is possible that the definition will change to category III before the launch of this mission. This would have a small impact on the complexity of the technology for JGO and subsequently on the cost and schedule. The ESA and NASA planetary protection officers are closely involved in the studies and will provide the study lead with latest information on mission categories when new information becomes available.

The recommendation of the Planetary Protection Working Group [RD 20], that was initiated to support the CDF study, is as follows: As the S/C does not contain or operate with any radioactive sources (RTGs, RHUs), it will not itself be capable of creating conditions warm enough for living

systems to replicate. The surface of Callisto is extremely ancient and is therefore not a concern with regard to surface subduction and contamination of a subsurface liquid ocean in the same way as Europa. The 25% of Ganymede that is known is also ancient (100's of Millions of years), so should not be of concern from the perspective of an impacting orbiter reaching a sub-surface ocean. In the unlikely event that JGO uncovers recent geophysical features in the remaining 75% of the as yet unexplored terrain, the mission can be altered to facilitate a controlled descent at low  $\Delta V$  cost and impact to avoid such features (see section 4.4).



## 4 MISSION ANALYSIS

### 4.1 Introduction

This chapter gives a summary of the performed mission analysis, based on input from the EJSM Mission Analysis working group [RD 21] in the preparation phase and later by ESOC calculations performed in frame of the Concurrent Design Facility study in May/June 2008. The results of this study are presented in this section and are updated when additional information became available after the end of the CDF study.

### 4.2 Mission Phases

The descriptions of the mission phases are summarised in Table 8.

Major Phase	Minor Phase	Description	Start Date	End Date	DSM* [m/s]	Nav [m/s]	Duration [d]
<b>Launch</b>		Ariane 5 from CSG	11 Mar 2020		0	0	-
<b>Low Earth Orbit Phase</b>		Cruise with instrument calibration	11 Mar 2020	4 Feb 2026	0	80	2156
<b>Interplanetary</b>		VEEGA manoeuvres			40	85	
		S/C health checks Trajectory correction manoeuvres					
<b>Jupiter and Resonant Orbits</b>	JOI	Jupiter Orbit Insertion	4 Feb 2026		940	10	-
	From Arrival to GGA2	Jupiter magnetosphere and surface science	4 Feb 2026	02 Aug 2026			179
	From GG2 to GGA6	5 Ganymede fly-bys for $\Delta V$ saving	02 Aug 2026	16 Dec 2026	94	40	136
	From GG6 to Callisto	Orbit change to Callisto	16 Dec 2026	11 Feb 2027	30	40	57
	Callisto Science	Resonant orbit with 19 fly-bys	11 Feb 2027	29 Feb 2028	152	180	383
	Callisto to Ganymede	Orbit change to Ganymede	29 Feb 2028	22 May 2028	164	20	83
<b>Ganymede Orbits</b>	Elliptical	Initial elliptic orbit (200 x 6000 km)	22 May 2028	10 Aug 2028*	985 <sup>‡</sup>	10 <sup>‡</sup>	80*
	Circular	Circular orbit (200 km)	10 Aug 2028**	06 Feb 2029*			180*
<b>End of Life</b>		Impact on Ganymede surface	06 Feb 2029		0	0	-
<b>TOTALS</b>					<b>2870 (no margin)</b>		<b>3254 d</b>
					<b>2990 (w/ margin)</b>		<b>(8.9 yr)</b>
* Propulsive manoeuvres							
** These are the start and end dates according to the longer phase durations of 80 days and 180 days for the elliptical and circular phase respectively.							
‡ These values are for shorter phase durations, as shown in MA 2020. They therefore represent a lower boundary for the necessary $\Delta V$ and a thorough $\Delta V$ analysis with the longer phase durations needs to be performed at a later stage.							

**Table 8: Mission phases updated for the 2020 launch date for JGO.**

#### 4.2.1 Launch

Ariane 5 was selected as the launch vehicle, as further described in Section 3.2. A transfer analysis was performed (Table 9) and in the time frame between 2018 and 2024 three favourable launch windows were identified.

Initially in the Cosmic Vision plan a launch date of 2018 was foreseen. This was changed in summer 2008 to a launch in 2020 in order to satisfy programmatic reasons and in particular to synchronise the NASA and ESA launch dates. The best solution in (Table 9) would be option 7a with launch in 2019, with a good back-up in 2020. But for the above mentioned reasons, a launch in 2020 is selected (option 9a).

**Table 9: Best results of transfer analysis for Ariane 5 between 2018 and 2024.**

CP Transfer to Jupiter with Ariane-5 direct escape																						
CAS	LAUNCH					CRUISE						ARRIVAL to 4 x 250 Re				FINAL						
	date	V-inf	dec	kg (2)	DV	DV	swb	swb	DV	swb	DV	swb	DV	kg	date	V-inf	dec	DV	DV	kg	yea	
4a	18/03/23	3.517	0	4078	165	0		19/04/13	0	20/05/06	0	22/05/06	0	3864	24/09/10	5.943	-2.9	828	993	2948	6.5	
7a	19/03/13	2.500	0	5025	190	291		20/03/23	20/09/04	21/07/08	15	23/07/08	0	4273	25/09/22	5.888	-4.8	818	1314	3271	6.5	
9a	20/03/11	3.388	0	4207	165	0		20/07/01	0	21/04/27	39	23/07/28	0	3936	26/02/04	5.501	-4.5	743	947	3087	5.9	Baseline
9b	20/03/01	3.563	4	3676	165	0		20/06/27	0	21/04/24	0	23/07/26	0	3483	25/12/21	5.539	-3.6	750	915	2726	5.8	NASA solut
11a	21/06/03	3.973	-5	3678	165	0		22/06/14	0	23/06/27	0	25/10/17	0	3485	28/05/11	5.440	-4.0	731	896	2744	6.9	Back-up 1
12a	21/10/21	3.964	0	3597	165	0		22/04/28	316	23/10/04	1	25/10/04	0	3073	28/07/04	5.538	-13.0	749	1231	2406	6.7	
130a	22/05/09	2.500	0	5025	190	240		23/05/15	23/10/18	24/08/08	288	26/11/07	0	3974	29/06/07	5.471	-5.3	738	1456	3122	7.1	
131a	22/05/16	2.900	0	4676	190	23		23/05/15	23/10/18	24/08/08	288	26/11/07	0	3970	29/06/08	5.470	-5.3	738	1239	3119	7.1	Back-up 2
14a	23/06/16	3.500	-21	3869	165	0		23/11/26	0	24/10/24	2	26/10/25	0	3663	30/01/21	5.589	6.6	759	926	2859	6.6	
15a	24/08/19	3.500	-20	3906	165	0		25/08/31	0	26/10/02	0	29/01/23	0	3701	31/11/14	5.766	1.2	793	958	2856	7.2	

(1) Additional DV: Launch window = 50 m/s; Launcher dispersion correction = 30 m/s; Navigation = 25 m/s per swb; Jupiter approach = 10 m/s  
 (2) Addapter of 155 kg subtracted

As of September 2008, the baseline mission scenario is with an Ariane 5 ECA launch in March 2020 from Kourou. Direct escape would be performed with an escape velocity of ~3.39 km/s and a declination of 0 deg. A chemical propulsion approach with gravity assists is used.

#### 4.2.2 The interplanetary cruise phase

The transfer from Earth to Jupiter would be achieved by performing a series of Gravity Assists (GA). The best performance is obtained with a Venus-Earth-Earth Gravity Assist (VEEGA) sequence, with a trade-off between the minimal  $\Delta V$  manoeuvres and the shortest transfer time. Figure 16 shows in red the VEEGA transfer trajectory in 2020.

#### 4.2.3 Jupiter orbit insertion and planetocentric phase

The arrival date for the planetocentric phase of the tour is February 2026. The  $V_{inf}$  w.r.t. Jupiter would be ~5.5 km/s and the declination w.r.t. Jupiter's equator would be -4.5 deg. A Ganymede Gravity Assist (GGA) would be performed before Jupiter Orbit Insertion (JOI). The JOI (Jupiter Orbit

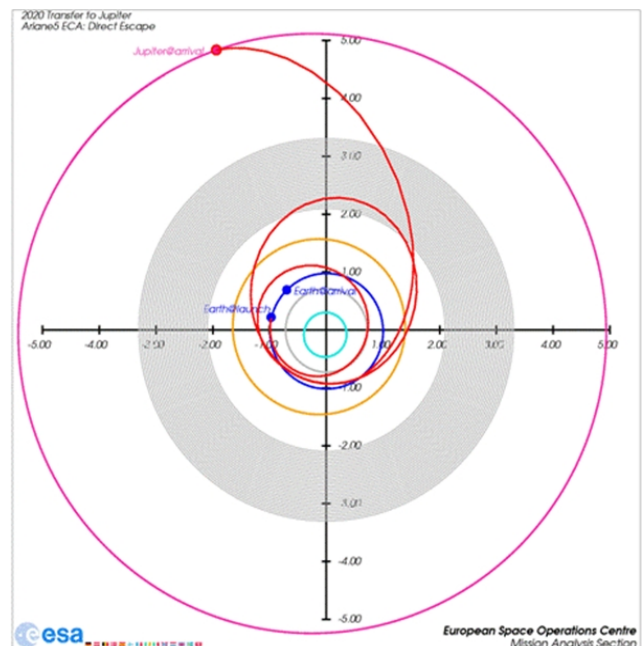

**Figure 16: Transfer from Earth to Jupiter with an Ariane 5.**

Insertion) capture orbit is a  $13 \times 245R_J$  orbit. Gravity assist at Io and Europa are not planned in order to avoid high radiation doses. Jupiter arrival is scheduled for Feb. 2026 with a  $V_{inf} = 5.501$  km/s.

JOI would be followed by injection into a highly elliptic orbit, followed by a PeriJove Raising Manoeuvre (PRM) at apoJove. Resonant GGAs are used to:

- reduce the orbital period
- reduce the inclination
- reduce the infinite velocity w.r.t. Ganymede

#### 4.2.4 Callisto Science Phase

The next phase is a Callisto **science phase**, where the spacecraft is placed in a resonant orbit with Callisto. These resonant orbits enable frequent passes and a good coverage of Callisto. 19 Callisto fly-bys are foreseen, within a total duration of 383 days. The  $V_{inf}$  remains close to 2.05 km/s and the radiation dose picked up during this phase is 21 krad.

In Figure 17 a snap shot of the Callisto science phase is shown at one of the 19 fly-by's at Callisto. The Figure illustrates the nature of the resonant orbit.

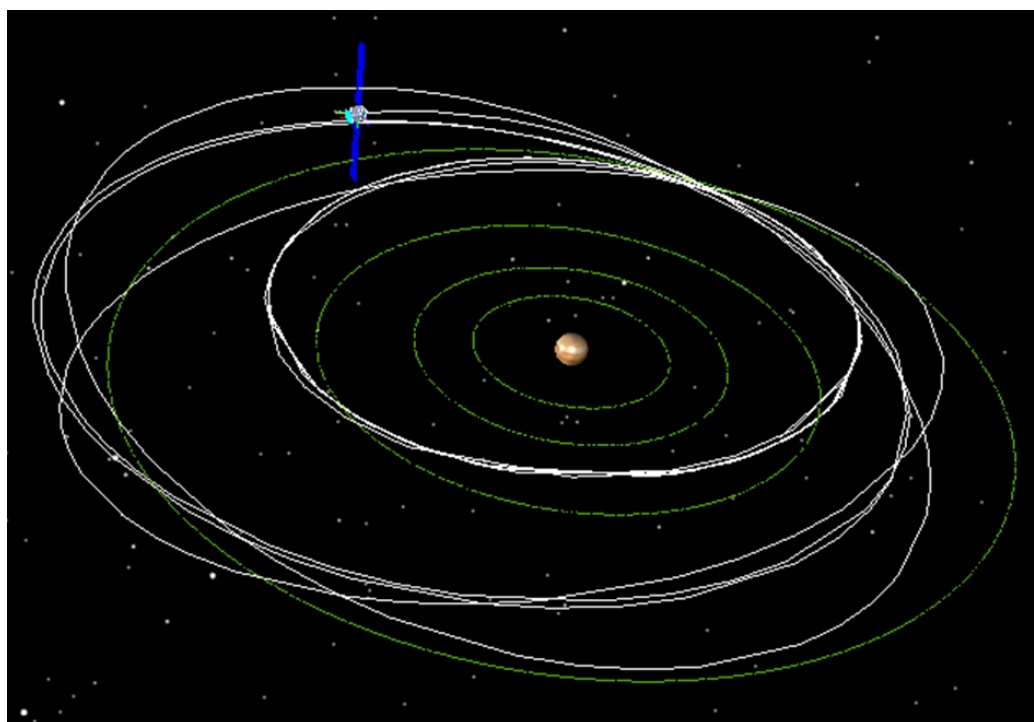

**Figure 17: Part of the science phase around Callisto. Jupiter is in the centre, the orbits of the Galilean moons are shown in green, Callisto and Ganymede are represented by grey spheres. A part of the trajectory of JGO is shown in white.**

#### 4.2.5 Ganymede approach and orbit

After the Callisto science phase, the spacecraft moves from Callisto to **Ganymede orbit**, with a gravity assist sequence of Callisto-Ganymede-Ganymede (CGG), taking 76 days. All GA are

tuned such that they are almost all performed at the minimum altitude (200 km). Additional deep space manoeuvre cost 130 m/s in this phase. These manoeuvres result in a  $V_{inf}$  at Ganymede of 936 m/s.

This is the start of the **Ganymede science phases**, with first a near polar **elliptical** orbit followed by a **circular** phase.

#### 4.2.5.1 *Elliptical orbit*

The initial argument of pericenter is set to 141.8 deg for the elliptical orbit of 200x6000km. The natural lifetime of this orbit, before it degrades significantly, is around 190 days and limited due to Jupiter gravity disturbance. However, the maximum duration of this mission phase is set to 80 days, due to radiation dose constraints. This disturbance causes the pericenter going up to 1000 km and apocenter down to 1100 km, resulting in an almost circular orbit. For this quasi polar orbit, the inclination and the ascending node remain almost constant.

The maximum eclipse duration of this phase is around 0.8 hours. The total radiation dose is 15 krad behind 8mm Al shielding within 80 days.

#### 4.2.5.2 *Circular orbit*

The radius of the circular orbit would be 200km and the eccentricity remains quasi-stable at 0 for almost 150 days. After approximately 150 days, a 200 km orbit can be re-initialized with a cost of few m/s. As the circular orbit is significantly more stable than an elliptic orbit, the natural lifetime is 270 days. The maximum duration of this mission phase is set to 180 days, due to radiation dose constraints (the design point is <100 krad). For a quasi polar orbit, the inclination and the ascending node remains almost constant. The maximum eclipse duration is around 0.92 hours. Good global coverage is achieved in less than 150 days whereby most points on the surface get more than 12 passes. Total coverage is achieved over the full life time. The total radiation dose in 180 days is 33 krad for 8mm Al shielding.

#### 4.2.6 Mission Analysis Trade-offs

Several other options to the presented mission profile were evaluated:

**Europa fly-by:** the JGO passes by Europa and releases a penetrator. In this case, the  $V_{inf}$  with respect to Europa would be 2.7 km/s. The tour would be prolonged by 40 days and 100m/s. Most importantly, the JGO would experience an additional 100 krad, which precludes this option.

**Small body fly-by:** A fly-by at Jovian small bodies can only be performed if the small body ascending node is in the vicinity of the right ascension of the Jupiter incoming infinite velocity, as small bodies are inclined with respect to the ecliptic plane. Preliminary calculations for the small body Praxidike result in fly-by cost of >700 m/s for a targeted fly-by. An untargeted fly-by at 1 million km would delay Jupiter arrival by 7 Ganymede revolutions which in turn results in a reduced mass. A small body fly-by appears unfeasible.

### 4.3 Ground Segment

For nominal spacecraft operation JGO would be controlled by ESA's mission operations centre (ESOC) and ESA's ground station network (ESTRACK). Three X-band LEOP stations (Kourou, Cebreros, New Norcia) are available.

The Cebreros (see Figure 18) 35 meter single station would be used during the cruise phase and the observation phase at Jupiter. This is supported by New Norcia for critical phases such as e.g. fly-bys and insertion. Main communication would be performed in X-band. For radio science Ka band would be required from Cebreros.

Additional support by NASA/JPL Deep Space Network (DSN) could be considered, especially when 24 hour coverage would be required for critical events.

Science operations for JGO would be performed by ESA/ESAC. Close coordination with the JEO science operation centre at JPL would be put in place for campaign and synergistic observations. A centralized JGO data distribution system would be developed at ESAC that would allow each PI science team to access the data related to their instruments or interdisciplinary investigations and spacecraft housekeeping data. The JGO Science Operations Centre (SOC) concept will be further elaborated during the next study phase.



Figure 18: ESA's Cebreros Station near Avila, Spain.

### 4.4 End of mission options

Currently it is foreseen to impact JGO on Ganymede's surface in an **uncontrolled** way as soon as the science measurements are completed.

A **controlled impact** with a de-orbit burn would cost ~ 15m/s. In case of an impact the impact error would be in the order of kilometres.

The **weak escape strategy** would cost around 900 m/s and is not affordable. Also, the maximum radiation dose would be exceeded. It is therefore discarded.

### 4.5 Change of launch date to 2020 and P/L complement

During this CDF study the targeted launch date was 2018, which was shifted after the finalisation of the CDF to 2020 for programmatic reasons. Therefore the complete mission analysis had to be redone. The changes resulting from these new results are implemented in this document and summarized below:

- The launch date shifted from 18 March 2018 to 11 February 2020.
- The maximum launch mass increased from 4077 kg to 4362 kg.
- The transfer time decreased from 6.5 years to 5.9 years.

In Table 10 a general overview over the major changes due to the new later launch date is given:

**Table 10: Table of design updates for launch date 2020.**

<i>Structures / Configuration</i>	No change (updates to design fit inside current structure)
<i>Thermal Control</i>	No change
<i>Mechanisms</i>	<b>Removed Langmuir boom mechanisms (no deployment required)</b>
	<b>Added Radar booms</b>
	<b>SA mechanism unchanged, since SA area changed only marginally (+2%)</b>
<i>Communications</i>	No change
<i>Data Handling</i>	No change
<i>AOCS</i>	<b>Removal of NAC relaxes pointing constraints</b>
	<b>Current system is over-specified</b>
	<b>No change but potential for savings</b>
<i>Propulsion</i>	No change (current tank size still sufficient)
<i>Propellant</i>	<b>New trajectory results in total <math>\Delta V</math> decreased by 45 m/s</b>
<i>Power</i>	<b>Small increases in AOCS and Mechanisms power consumption leads to slightly larger SA</b>
	<b>Battery size reduced using updated calculations</b>
<i>Harness</i>	<b>Updated to reflect new dry mass</b>
<i>Instruments</i>	<b>Added SWI and TM, removed LP-PWI and NAC</b>
<i>Radiation</i>	No change (rough estimate of shielding mass still applicable)

In general, the later launch date proved to be beneficial for the mission considering the increased launch mass and shorter transfer time to the Jupiter system.

A mass budget summary is given in Table 11 for launch dates 2018 and 2020. The reduced launch mass is mainly due to the reduced  $\Delta V$  for the 2020 launch date, which results in a saving of 45 m/s.

**Table 11: Mass budget summary.**

Subsystem	Margin	Launch 2018 [kg]	Launch 2020 [kg]
Launch capability (incl. 190 kg adapter)		<b>4070</b>	<b>4362</b>
Structure	19%	141	141
Thermal Control	20%	40	40
Mechanisms	10%	37	37
Communications	17%	45	45
Data Handling	10%	15	15
AOCS	5%	51	51
Propulsion	5%	166	166
Power	10%	320	322
Harness	20%	79	80
Instruments	18%	79	87
Radiation	0%	80	80
Total Dry Mass		1053	1063
System margin	20%	211	213
<b>Total Dry Mass with Margin</b>		<b>1264</b>	<b>1275</b>
Propellant	0%	2060	2027
Adapter mass	0%	190	190
Total Wet Mass		3324	3303
<b>Launch Mass</b>		<b>3514</b>	<b>3493</b>

Note that the margins applied in this document are in accordance with the *Margin philosophy for assessment studies* document [RD 22].

Propellant is calculated using the total dry mass including margins. As there is already a margin on the  $\Delta V$ , no extra margin on the propellant is used.

Table 12 shows the dry mass margin for the JGO baseline launch in 2020, which is 335 kg. The maximum possible dry mass when using the same propellant tanks would be 1500 kg, leaving a dry mass launch margin of 225 kg. If custom made tanks were used, the total dry mass could go up to 1610 kg.

**Table 12: Dry mass launch margin calculations.**

	Baseline [kg]	Maximum using same tanks [kg]	Maximum using custom made tanks [kg]
Total dry mass with margin	1275	1500	1610
Propellant mass	2027	2383	2562
Dry mass launch margin	335	225	0

## 5 THE SPACE SEGMENT

### 5.1 Requirements

The requirements for the mission are outlined in the EJSM/JGO Mission Requirements Document [RD 18]. A summary of the top-requirements is given here:

- Cost: L-Class Mission (650M€ cost at completion, excluding nationally provided payload)
- At least TRL 5 by 2011 for all equipment and payload
- European equipment wherever possible
- Launch: Ariane 5 ECA from CSG
- Launch Date: 2020
- Chemical Propulsion
- 3-axis stabilized spacecraft
- Total Ionizing Dose: below 100 krad
- Use of solar power to be compatible with European launch restrictions
- Avoidance of Solar Arrays with concentrators due to low technology maturity
- Direct communications link between the Spacecraft and the Earth (avoidance of a relay satellite)

### 5.2 Baseline Design

This section provides the main characteristics of the JGO spacecraft subsystems.

#### 5.2.1 Structures and Configuration

The general **requirements** and design drivers for the configuration are:

- The overall composite configuration shall fit in the fairing of the Ariane 5
- The configuration shall accommodate all equipment and instruments
- The configuration shall provide unobstructed fields of view for the science instruments, the sensors and the antennas, and unobstructed deployment for mechanisms
- The configuration shall provide access for the AIT (Assembly, Integration and Testing), including servicing of components during ground operations.
- The complexity of the configuration shall be kept to a minimum, in order to minimise cost and AIT complexity.

The major **drivers** for the structural design are:

- Accommodation of propellant and pressurant tanks



- Accommodation of the High Gain Antenna (2.8 m diameter)
- Accommodation of the 500N-main engine
- Shielding of instruments and avionics

The two propellant tanks are positioned on the centre-line of the S/C within the main structural central cylinder. This concept provides stiffness for the overall spacecraft and locates the large amount of propellant mass near the centreline. The HGA is mounted at the top of the S/C with a truss structure, while the main engine is mounted at the bottom. Other subsystems are attached to the four exterior, rectangular panels, which are reinforced by interior panels. Since most of the equipment and instruments do not have high masses, the panel structure requires relatively low mass.

Figure 19 shows the central cylinder and structure of the body and the two main tanks that are positioned inside the main cylinder.

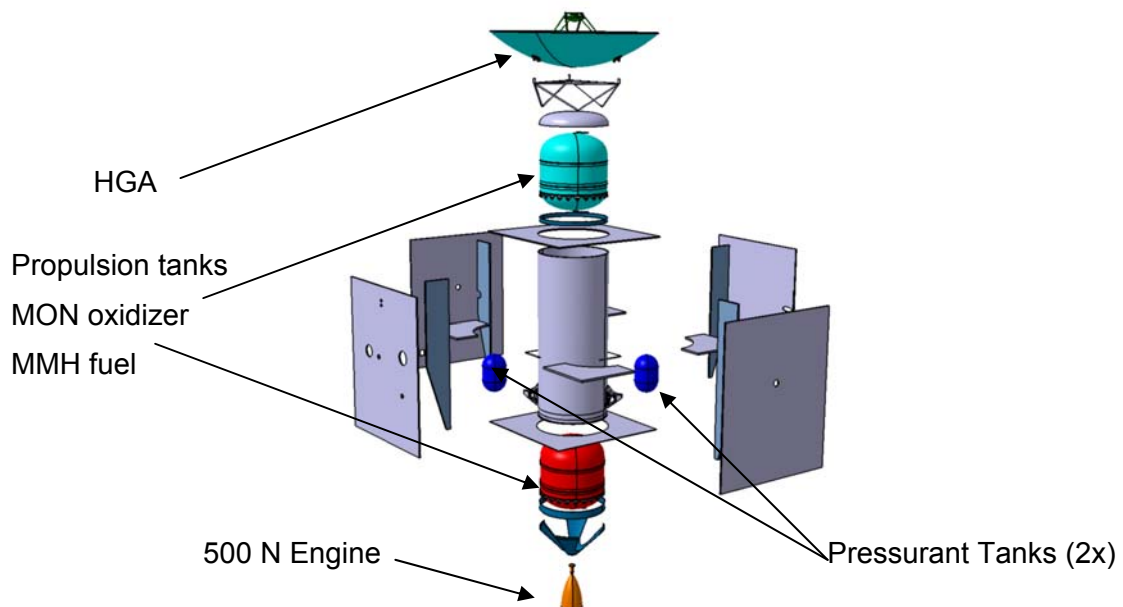

**Figure 19: Main configuration driver, central cylinder for large propulsion tanks; exploded view.**

The Solar Panels of Rosetta have been taken as reference for the JGO configuration, but with 4 panels on each of the wings, instead of Rosetta's 5 panels each (see Figure 20) and using GaAs triple-junction cells. JGO requires  $\sim 51 \text{ m}^2$  solar panels compared to  $68 \text{ m}^2$  for Rosetta.

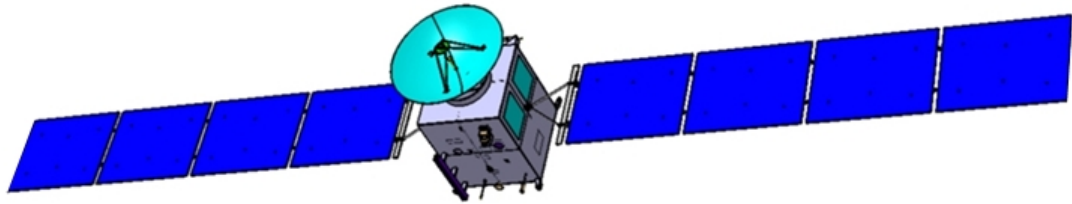

**Figure 20: JGO with deployed solar panels.**

Just after the deployment of the solar panels, the various instrument booms would be deployed. Figure 21 shows the fully deployed spacecraft, with the booms for the different instruments extended.

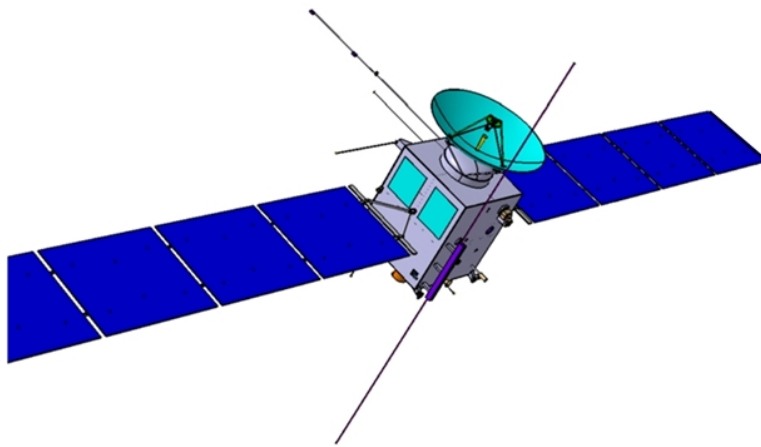

**Figure 21: Fully deployed S/C.**

The tentative accommodation of science instruments (payload complement shown is the CDF configuration (see section 2.5.4) on the spacecraft is shown in Figure 22.

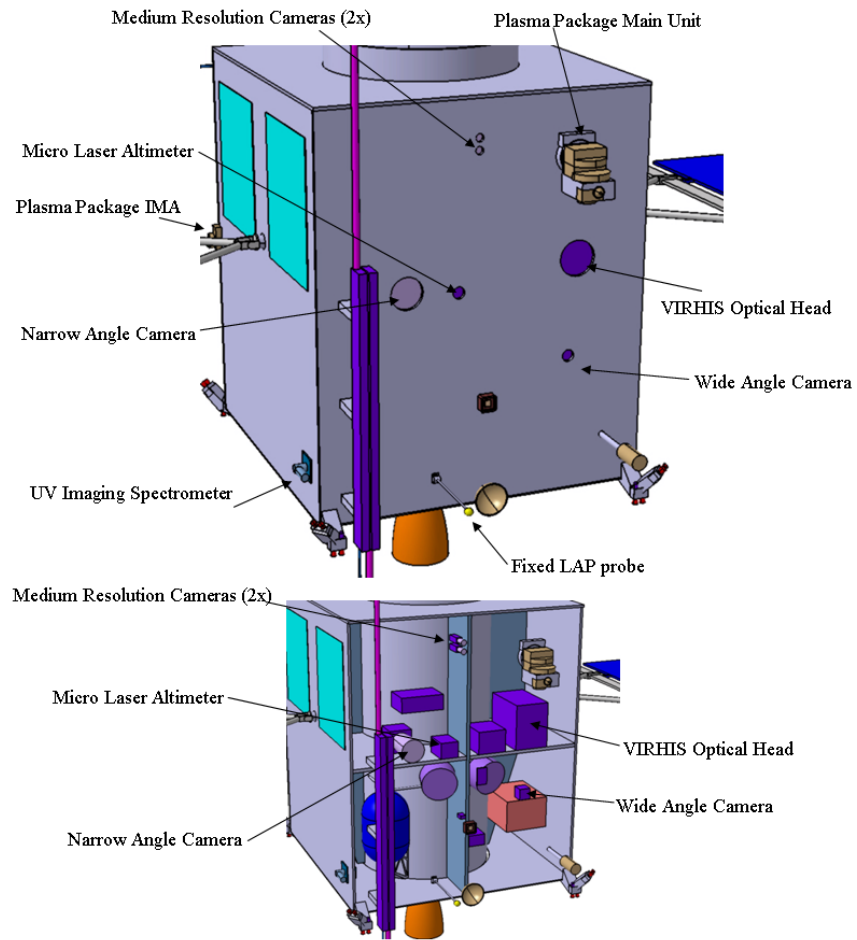

**Figure 22: Tentative CDF instrument accommodation on the zenith side (top), and cutaway of the zenith side (bottom).**

Figure 23 shows the main dimensions of the JGO spacecraft.

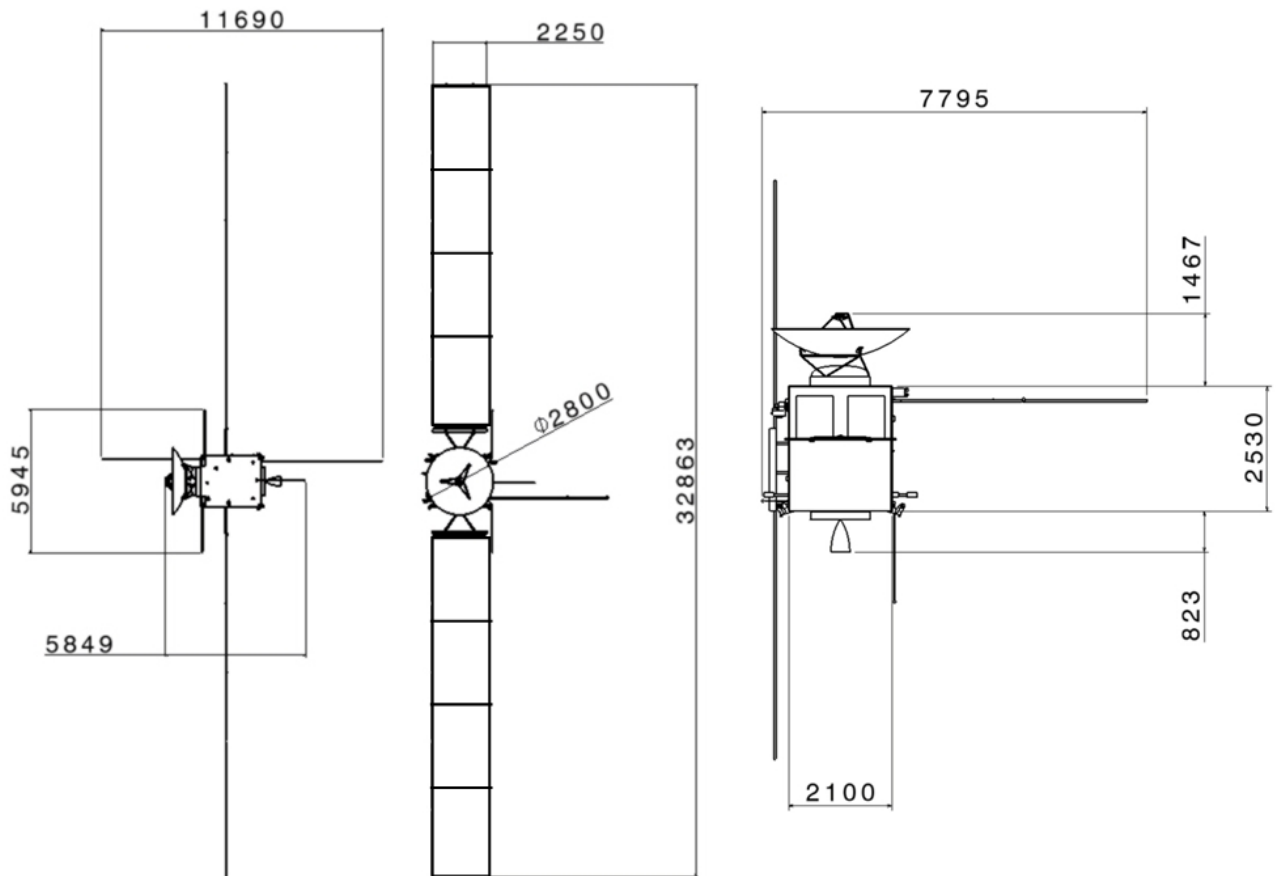

**Figure 23: Main dimensions of the JGO spacecraft.**

## 5.2.2 Power

The Power subsystem consists of two main parts: solar arrays and batteries. The required Power Control and Distribution Unit (PCDU) has a mass of 12.4 kg. The regulated power bus is at 28 V.

### 5.2.2.1 Solar Arrays

The spacecraft is equipped with deployable, rotating solar arrays of Triple-Junction GaAs cells. The use of solar concentrators is not foreseen. The solar array size was dimensioned for a mission to Jupiter and the Galilean moons. The power profile with respect to science operations and communications was carefully assessed. The following assumptions were considered:

- $\sim 51 \text{ W/m}^2$  Sun illumination at Jupiter orbit
- $2640 \text{ W/m}^2$  Sun illumination at Venus orbit
- $-108 \text{ }^\circ\text{C}$  solar array temperature at Jupiter
- Solar cells: 28% efficiency of the GaAs solar cells at LILT (low intensity low temperature) conditions at beginning of life (BOL); 20% degradation during the mission life time; mass including substrate  $\sim 4.94 \text{ kg}$ .

According to the power budget reported in [RD 03], the sizing case for the solar array is the Jupiter Orbit mode, requiring 417 W. Additionally, PCPU inefficiency and system margins have to be added, which results in a power requirement of **539W at end of life (EOL)** at Ganymede orbit [RD 03]. Taking into account the solar cell degradation (see also section 5.2.2.2), pointing losses, and path efficiency, the available maximum power (Pmax) at Jupiter using these solar cells is reduced to 10.55 W/m<sup>2</sup>. The available power at the different phases of the mission is shown in Table 13.

**Table 13: Available solar array power during the mission.**

Phase	Available power @ Venus [W]	Available power @ Jupiter [W]	Pmax [W/m <sup>2</sup> ] @ Jupiter	SA area [m <sup>2</sup> ]
Cruise	23763			
Jupiter to GGA2		609		
GGA2 to GGA6		607		
GGA6 to Callisto		572		
Callisto science		565		
Callisto to Ganymede		563		
Ganymede science (elliptical)		556		
Ganymede science (circular)		539	<b>10.55</b>	<b>51.07</b>

The EOL requirement of 539W together with the Pmax at Ganymede orbit of 10.55 W/m<sup>2</sup> results in a solar cell array surface of **51m<sup>2</sup>** and a mass of 282 kg (incl. margins).

Optimum pointing of the Solar Arrays to the Sun during all modes is required to provide the required power (see section 5.2.5.1). In the current design this results that the instrument bore sight is rotated continually (yaw) in Ganymede circular orbit. Mitigation strategies to avoid this yaw rotation, at least during operational phases of instruments which have problems with this rotation will be studied in the industrial studies.

#### 5.2.2.2 Solar cell degradation

The radiation environment at Jupiter is severe and as a result the power output of the solar cells decreases over the life time of the mission. To reduce this effect, cover glass needs to be used to shield the cells. An analysis of the solar cell degradation for the different phases of the JGO mission as functions of the cover glass thickness was performed and the results are shown in Table 14. A dedicated version of the EQFRUX code available in SPENVIS [RD 08] was used. In the analysis it was assumed that 10MeV protons cause equivalent damage to 1000 1MeV electrons for maximum power (Pmax) in GaAs cells. Infinite rear-side shielding of cells was also assumed.

Table 14 shows the resulting predicted equivalent 1MeV electron fluence for solar cell degradation for the different phases of the JGO mission as functions of the cover glass thickness. For the CDF study, the 70um cover glass was chosen.

**Table 14: Equivalent 1MeV electrons for Pmax for GaAs solar cells degradation**

Phase	Cover glass thickness	Duration* [days]	0 $\mu\text{m}$	25 $\mu\text{m}$	70 $\mu\text{m}$	76 $\mu\text{m}$	152 $\mu\text{m}$	305 $\mu\text{m}$	509 $\mu\text{m}$	761 $\mu\text{m}$
			[#/cm <sup>2</sup> ]	[#/cm <sup>2</sup> ]	[#/cm <sup>2</sup> ]	[#/cm <sup>2</sup> ]	[#/cm <sup>2</sup> ]	[#/cm <sup>2</sup> ]	[#/cm <sup>2</sup> ]	[#/cm <sup>2</sup> ]
Cruise		2397	7.4E+15	7.7E+14	3.5E+14	2.9E+14	1.3E+14	6.8E+13	4.0E+13	2.4E+13
Jupiter arr. to GGA2		179	3.0E+12	2.9E+12	2.8E+12	2.8E+12	2.6E+12	2.3E+12	1.9E+12	1.5E+12
GGA2 to GGA5*		100	5.2E+12	4.9E+12	4.5E+12	4.4E+12	4.0E+12	3.4E+12	2.8E+12	2.3E+12
GGA5 to Callisto		37	2.4E+15	3.7E+14	1.0E+14	6.7E+13	2.3E+13	8.8E+12	5.1E+12	3.4E+12
Callisto science		383	2.5E+13	2.3E+13	2.1E+13	2.1E+13	1.8E+13	1.5E+13	1.2E+13	9.8E+12
Callisto to Ganymede		57	5.1E+12	4.9E+12	4.7E+12	4.7E+12	4.3E+12	3.8E+12	3.1E+12	2.5E+12
Ganymede science (elliptical)		80	2.6E+13	2.5E+13	2.4E+13	2.4E+13	2.2E+13	2.0E+13	1.6E+13	1.3E+13
Ganymede science (circular)		180	5.8E+13	5.6E+13	5.4E+13	5.4E+13	5.0E+13	4.4E+13	3.7E+13	2.9E+13
<b>Total</b>		<b>3431</b>	<b>9.9E+15</b>	<b>1.3E+15</b>	<b>5.6E+14</b>	<b>4.6E+14</b>	<b>2.6E+14</b>	<b>1.6E+14</b>	<b>1.2E+14</b>	<b>8.5E+13</b>

\*Note that the duration of the phases refers to the launch date and mission analysis calculations of 2018; the values for the 2020 launch date will not vary significantly.

### 5.2.2.3 Batteries

Batteries are required to provide power during eclipses and for safe mode. The battery sizing case was given by the science mode during eclipses (270 minutes maximum duration). During eclipse not all of the defined scientific instruments on board will operate, or at time-multiplexed operations. The most power-demanding combination of the instruments is 70 W. During the eclipse science mode, an additional 20 W is budgeted to provide heating to the instruments. This results in 90 W power available for instruments during eclipse.

The total spacecraft power consumption during eclipses is 341 W. This results in an end-of life (EOL) battery storage capacity of 1534 Wh. The battery is Li-Ion (ABSL based) and has a mass of 25.8 kg (incl. margins).

### 5.2.3 Thermal Control

The thermal control subsystem keeps the S/C and instruments within the specified temperature limits during the whole mission. The spacecraft must be protected both from high temperatures during the Venus fly-by, and from cold temperatures during operations around Jupiter.

Thermal control is provided by a 1.26m<sup>2</sup> optical solar reflectors (OSR) radiative surface mounted on the solar arrays. OSRs are preferred to paints because less sensitivity to radiation degradation. Additionally louvers (see Figure 24) are applied on radiators to adapt emissivity as function of power dissipation and to minimize heating power demands (like for Rosetta).

High temperature MLI is applied on the S/C external surface for shielding in the hot environment in the vicinity of Venus. MLI is also applied on tanks, thruster boxes, and pipe lines. Black paint covers the internal surfaces to minimize thermal gradients.

The thermal control equipment that was identified during the CDF study [RD 03] is listed in Table 15.



**Figure 24: Starsys (USA) louvers used in the ESA-Rosetta mission**

**Table 15: Mass budget for the thermal control system.**

Unit name	Mass per quantity excl. margin
MLI	<b>16.48</b>
Louvers + OSR	<b>8.99</b>
Black paint	<b>1.00</b>
Misc. (fillers, washers)	<b>1.00</b>
Tanks + Wrapping + Thrusters MLI	<b>3.70</b>
Heathers/Sensors	<b>1.93</b>
<b>Subsystem total</b>	<b>33.10</b>

#### 5.2.4 Propulsion

The main drivers for the propulsion subsystem are the required  $\Delta V$  to reach Jupiter, to perform the Jupiter tour with Callisto phase and orbit insertion and circularisation at Ganymede. In order to satisfy the mission  $\Delta V$  of ~2990 m/s (including margins), the baseline propulsion system is a bi-propellant MON/MMH system that feeds an EAM 500 N main engine, with a specific impulse ( $I_{sp}$ ) of 323 s. The 500N European Apogee Motor (EAM) was chosen as the main engine for the Laplace propulsion sub-system. Some of its characteristics are given in Figure 25. The engine will be at a TRL level of 8 in 2011, when it is planned to be launched with Alphabus.



**Figure 25: EAM main engine details.**

The propellant and oxidiser are stored separately in two 1108-liter OST-22/X cylindrical tanks, and are supported by two He-pressurant tanks. A schematic of the propulsion system is shown in Figure 26.

Two sets of eight 10N-thrusters are used for attitude control and wheel unloading.



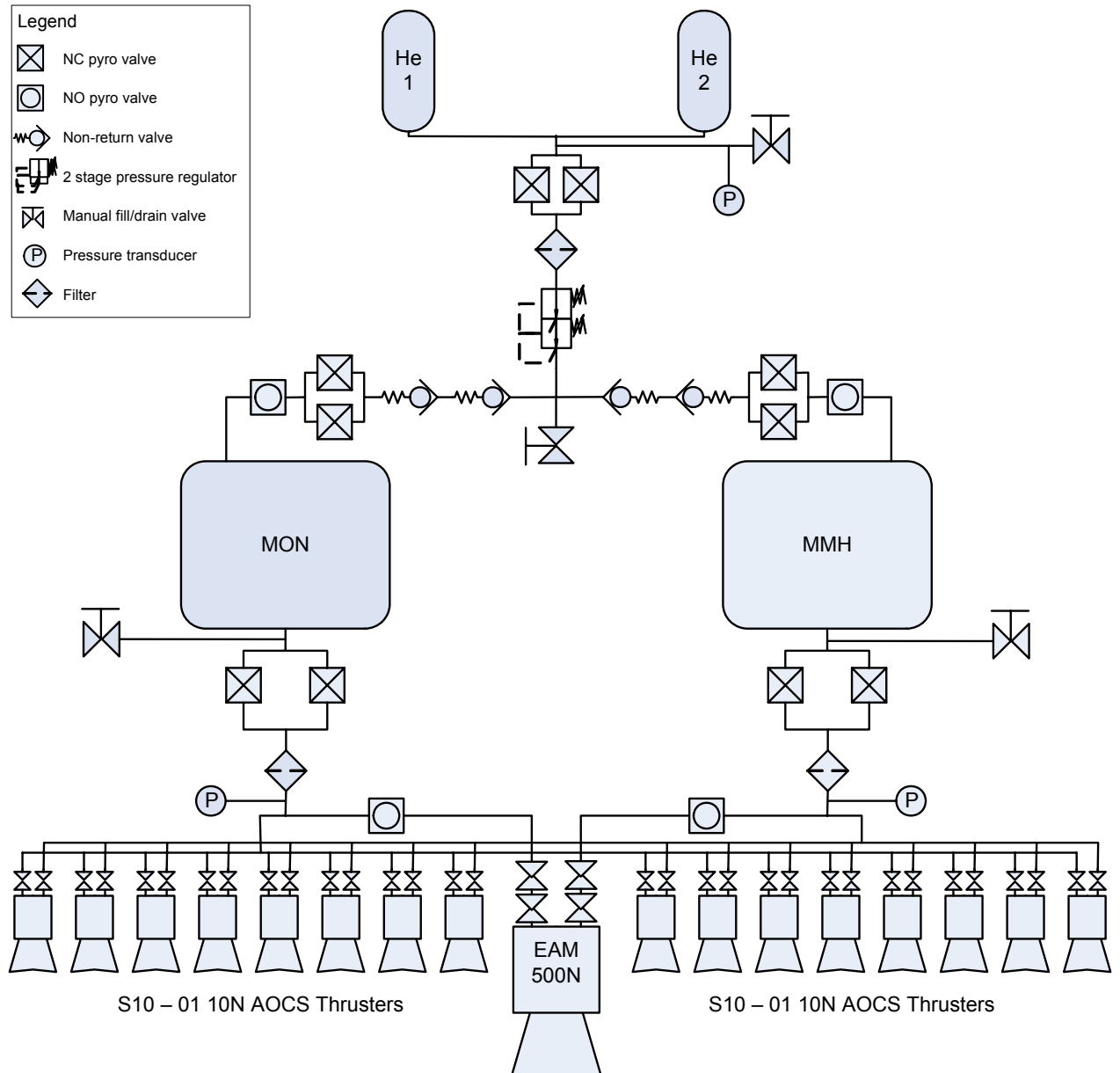

Figure 26: Propulsion sub-system schematics.

## 5.2.5 Attitude and Orbit Control Subsystem (AOCS)

The 3-axis stabilized attitude and orbit control subsystem (AOCS) allows for spacecraft pointing in particular during communication and nadir-observation phases. The pointing requirements are summarized in Table 16.

**Table 16: Spacecraft pointing requirements.**

Source	Requirement
HGA Pointing	~0.01 deg
SA Sun Acquisition	~0.1 deg
<b>Science Observations</b>	<b>~10 arcsec</b>

The pointing stability was driven by the narrow angle camera (part of the model payload during the CDF study, later discarded) and resulted in 0.3"/s over 0.5s. The current relaxation of pointing requirements because of the discarded NAC needs to be assessed in the industrial study. The next stringent requirements would result from the VIRHIS instrument (see section 2.5.2).

The AOCS consists mainly of four reaction wheels which are off-loaded regularly, two Star trackers, one internal measurement unit, and two Sun sensors. A navigation camera is used for critical manoeuvres. Correction manoeuvres and reaction wheel offloading are performed by the thrusters.

### 5.2.5.1 Solar Array Steering Analysis

During observation mode while in Ganymede orbit, JGO will be oriented towards nadir, while the solar arrays will have to remain sun-oriented. If the Sun is in the orbital plane, then a single-axis Solar Array Drive Mechanism (SADM) enables to keep the orientation of the solar panels perpendicular to the sun. If the orbital plane is in a non-zero angle with respect to Sun direction, then a rotation of the S/C around its nadir axis is required to ensure the correct pointing of the solar panels, and hence optimum power production.

For the Ganymede orbit the axis of rotation for the solar arrays is in the orbital plane and therefore the nadir-axis rotation angle is maximal when the S/C is at the pole, and zero at the equator (see Figure 27).

An alternative to rotating the Solar Arrays could be to oversize the SAs to cope with a degradation of power supply due to Sun-Ganymede-JGO angle variation; the required additional size is proportional to the inverse of the cosine of the maximal angle, so typically ~11% for a 25° angle. This analysis will be performed in more detail at a later stage.

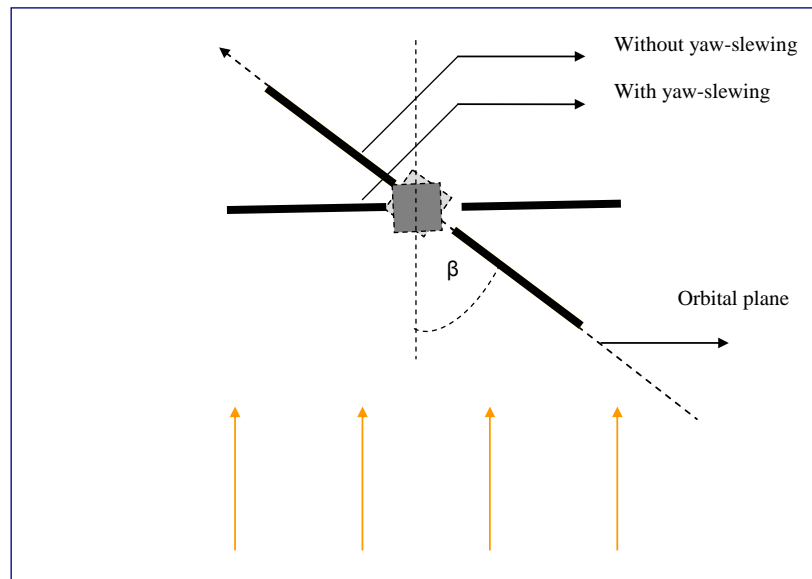

**Figure 27: Illustration of SA orientation for JGO above North Pole, with and without slewing the solar arrays. The yellow arrows indicate the Sun direction.**

#### 5.2.6 Mechanisms

There are five primary mechanisms on the JGO spacecraft.

- **Solar Array Deployment:** the Solar Arrays (SA) are composed of 2 wings of 4 panels each, which must be deployed after release from the launch vehicle. The deployment mechanism includes root hinges, inter-panel hinges, synchronisation mechanisms and hold down and release mechanisms (HDRM). The JGO SA design is based on Rosetta.
- **Solar Array Pointing:** the Solar Arrays must be continually rotated to point to the Sun to achieve maximum power generation. It must be compatible with spacecraft manoeuvres, with a maximum speed of 27 deg/sec without exciting the SA fundamental frequency of 0.1 Hz. The JGO SA pointing mechanism design is also based on Rosetta.
- **Magnetometer deployment:** two magnetometers of mass 0.25 kg must be deployed on 3.3 m- and 5 m-long booms. The JGO design is based on Cluster and uses springs and hinges.
- **Penetrating Radar dipole antenna deployment:** a 10 m dipole antenna is created by deploying two 5 m-long booms on either side of the spacecraft. The JGO design is based on Sharad (on board Mars Reconnaissance Orbiter), and uses elastic collapsible springs.

## 5.2.7 Telecommunication

The telecommunications subsystem was designed to satisfy a data rate of 40 to 66 Kbps at a distance from Earth of 5 to 6.1 AU. Science data downlink is performed at X-band and radio science experiments (measurements of gravity fields) additionally at Ka-band. X-band up-and-downlink is foreseen for TC/TM.

To communicate with ground stations, the JGO is equipped with a 2.8 m High Gain Antenna (HGA). In order to point the HGA towards Earth during communications, two options were examined:

- Use a pointing mechanism to allow the spacecraft to point the HGA at Earth. This allows instruments to remain nadir pointed and science operations to continue.
- Fix the HGA to the spacecraft. This requires the entire spacecraft to move in order to point the HGA, which interrupts science operations.

The critical phase of the mission for communications is the orbit around Ganymede. As the solar aspect angle varies by over 120 deg in this phase, to continually point the HGA at Earth would require a 2 DoF mechanism. The mass and power requirements on such a mechanism for a 2.8 m antenna were deemed to be unacceptably high. Therefore, a pointing mechanism was not baselined and instead a split was made in spacecraft operations between science observation and communication with Earth.

The Cebreros ground station is foreseen for main communications (see section 4.3, page 77). The ground station is assumed to be available for a window of 8 hours per day.

### 5.2.7.1 Baseline design

In summary, the on-board TT&C subsystem is implemented in X-band and based on:

- Two redundant X/X/Ka transponders for telecommands reception, transmission of the house keeping and science data
- Two redundant TWTA's X-band (Travelling Wave Tube Amplifiers)
- Two omni-directional LGA's for Launch and Early Operations Phase (LEOP) communication with the spacecraft
- One medium gain antenna for the transfer phase and for housekeeping
- One fixed 2.8m high gain antenna

Two redundant TWTA's Ka-band are included in the payload subsystem, therefore they are not mentioned in the communications equipment list. A 35 W Ka – TWTA has been traded off that would very slightly affect the mass budget (3.75 kg considering the following equipment list Table 17):

**Table 17: Equipment list with Ka-TWTA.**

Unit	Quantity	Mass per Quantity excl. margin	Margin	Total mass incl. margin
X/X/Ka Transponder	2	3.5	10.0	7.7
35W X-TWTA	2	2.2	10.0	4.8
35W Ka-TWTA	2	1.7	20.0	4.0
RFDU & Harness	1	4.0	20.0	4.8
Low Gain Antenna LGA	2	0.3	20.0	0.6
Medium Gain Antenna MGA	1	2.3	20.0	2.8
2.8m HGA	1	20.0	10.0	24.0
<b>Subsystem Total</b>		<b>41.7</b>	<b>16.8</b>	<b>48.7</b>

### 5.2.8 Data handling

The data handling subsystem is required to provide downlink data rates of 40 to 66 Kbps. The design (see Figure 28) is based on a HICDS LEON2 dual redundant computer, currently prepared for ESA's BepiColombo mission. It consists of an integrated processor, TMTC modules including redundancies, and an integrated mass memory board and controller.

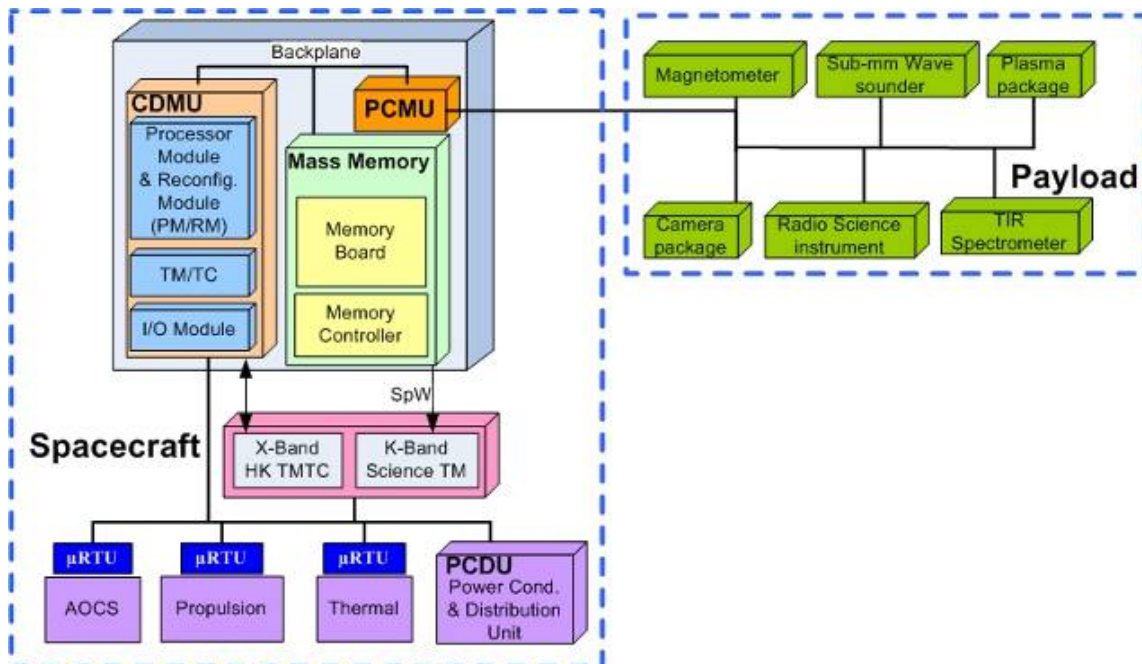

**Figure 28: Simplified schematics of data handling system. Note that not the complete P/L is depicted here.**

The data handling subsystem is required to store all science data and telemetry for up to 10 days in case of interruption of communications. It has been estimated that a board with FLASH technology could contain up to 1024/2048 Gbits of data space. For JGO, a very conservative approach is retained which leads to a single memory board of 256Gbits of size, which gives plenty of extra storage space and margin, while being very small in size. Table 18 shows other characteristics distinguishing the two technologies.

**Table 18: Mass memory technology comparison (source: EADS Astrium).**

Type	SDR SDRAM	DDR2 SDRAM	NAND FLASH
Device Capacity	512 Mbit	1 Gbit	8 (32) Gbit
Data Rate	1 Gbps	2 Gbps	≤ 22 Mbps Write ≤ 170 Mbps Read
Packaging	TSOP (gull wing)	FPBGA (ball grid)	TSOP / FPBGA (gull wing / ball grid)
Voltage	3.3 V	1.8 V	3.3 V
I/O Technology	LVTTL	SSTL_1.8	LVTTL
Typ. Power / device	20 mW standby 330 mW burst	10 mW standby 114 mW burst	66 μW standby 33 mW burst
Non volatility	No	No	Yes

## 6 PROGRAMMATICS

### 6.1 Schedule

For the EJSM/JGO mission the following schedule is foreseen:

Date/time frame	Action
January 2009	<b>Joint ESA/NASA down-selection</b> ; confirmation of down-selection by the ESA Science Programme Committee (SPC) in Feb. 2009
1 <sup>st</sup> quarter 2009	- Preparation for Invitation to Tender (ITT) for 2 parallel industrial studies
2 <sup>nd</sup> quarter 2009	- Call for instrument studies (Declaration of Interest for nationally funded studies) for the down-selected mission
2 <sup>nd</sup> quarter 2009	Issue of ITT for industrial assessment (1 year)
Mid 2009 – end 2010	2 Competitive industrial studies; nationally funded instrument studies in parallel
Late 2010	<b>Selection of 2 L-class missions for future study for launch in 2020</b>
Begin 2011 to mid 2012	<b>Industrial studies</b> (start of phase B1) – Definition Phase
End 2012 - end 2019	<b>Selection of 1 L-class mission for launch in 2020</b> → mission moves into phase B2/C/D
Early 2020	<b>Launch</b>

### 6.2 Management Approach

The following functions and responsibilities will be assigned by ESA for the study:

- ESA Study Scientist (SS):
  - Responsible for all science aspects related to the study needs
  - Interface with the Science Team
  - Active contribution to the mission definition during iteration phases
  - Acts as co-chair of the Joint Study Science Team
  - Specification of the science requirements and science management aspects
  - Defining the science operations requirements and the Science Operations Centre architecture
- ESA Study Manager (SM):
  - Overall study management, including schedule and resources management
  - Acts as satellite system engineer, with the support of the payload manager, the study scientist and experts
  - Responsible for all programmatic aspects
  - Ensures consistency between technology developments and mission needs

- Acts as the technical officer for the industrial assessment studies; in this function the industrial teams report to the SM and will be guided by the SM.
- Acts as the prime contact point for the interface with the NASA/JPL technical teams on technical matters
- ESA Study Payload Manager (SPM):
  - Acts as payload system engineer, with the support of experts
  - Responsible for payload interfaces, support the study manager for payload related technology developments
  - Follows payload assessment activities, including technology developments
  - Collection of payload specifications from the payload teams

Additionally technical support will be arranged as needed from ESA Technical Directorate.

The Study Manager will invite members of the Science Team and of NASA technical teams related to the Laplace/EJSM study to participate during critical milestones and review meetings with the purpose of ensuring transparency for the benefit of interface related issues and for the common science goals of the mission.

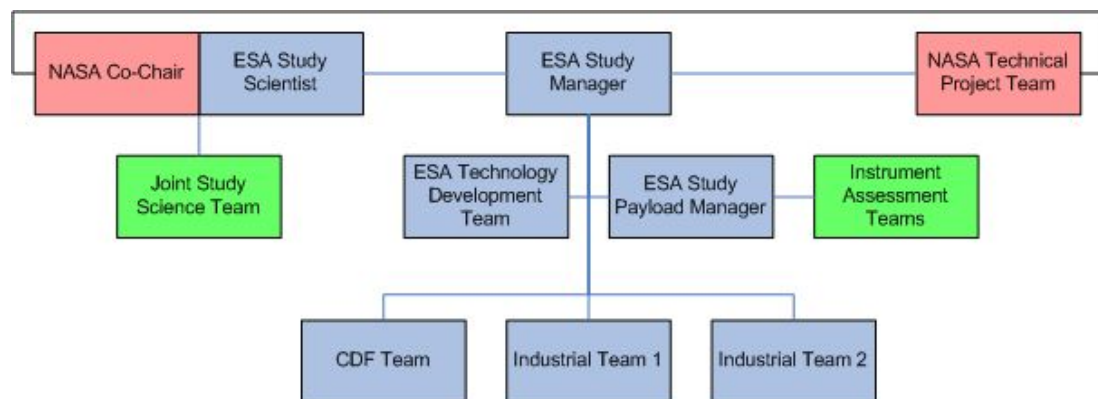

Figure 29: Organization of the ESA study team and interfacing with the NASA team.

### 6.3 Estimated Mission Cost

The EJSM/JGO mission fits within the ESA Cosmic Vision 2015-2025 L-class mission cost cap of 650M€ Cost-at-Completion to ESA, excluding nationally provided and funded payload. This is based on the preliminary cost estimate performed in frame of the CDF study [RD 03].



## 7 DEVELOPMENT PLAN

### 7.1 Technology for payload

The instruments for the JGO mission are foreseen to be nationally funded and provided by consortia of institutes led by Principal Investigators (PI). To enable an early proper definition of instruments and allow for a well defined accommodation already in early study phase assessment studies for the instrumentation will be required in parallel to the industrial study. These instrument studies have to be nationally funded and will be carried out by the prospective PIs.

In early 2009, ESA will issue a "**Call for Declaration of Interest for instrument studies**". Prospective PIs will be invited to respond to this call with details of the composition of nationally funded consortia, of the proposed work-plan and cost of the study. These consortia are expected to carry out assessment-level studies on the scientific instruments for JGO in parallel to the ESA funded industrial studies for the spacecraft. A description of the scope of the studies, study proposal selection procedure and interfacing with the ESA-managed industrial spacecraft studies will be provided in the call.

### 7.2 Running Technology Development Activities

#### 7.2.1 Testing of Low Intensity Low Temperature Solar cells in representative environment

One of the key challenges of this mission is to generate a sufficient amount of power at Jupiter. Solar cell arrays are foreseen for power generation (see section 5.2.2.1).

The solar power at Venus is  $2620 \text{ W/m}^2$  and the solar cells will be exposed to temperatures of 450 K, while at Jupiter the solar power is  $1/25$  of the solar power at Earth (i.e.  $51 \text{ W/m}^2$ ) and temperatures can be as low as 120 K. In the severe radiation and low temperature environment of the Jupiter system solar cells will degrade substantially. A proper understanding of the degradation is essential for the correct sizing of the solar array size and to be able to provide enough power until the end of the mission.

Testing and further development of solar cells which can endure such a harsh environment is currently ongoing. In an ESA-funded project, state-of-the-art triple-junction and dual-junction GaAs-cells are being tested under 'real' environmental conditions as given for the Jupiter mission scenario. This is done to specify the degradation at high total doses and under low intensity and low temperature conditions. The cells are irradiated with 1 MeV electrons with total fluences up to  $10^{16} \text{ e}^-/\text{cm}^2$  and temperatures of 120 K and 300 K to study the degradation profile. This project is expected to be completed in end 2009 (TBC).

#### 7.2.2 Jupiter Radiation Modelling

A main key challenge is the strong radiation at Jupiter (see section 3.4). An ESA-funded study on radiation mitigation methods and merging of different Jupiter radiation models started in summer 2008 and is expected to finish in end 2009 (TBC). This study will deliver a new radiation model which shall include the effect of the shielding of the moon for a spacecraft in orbit. It will also extend the energy range and distance range from Jupiter, for which this model is valid, with additional information from recent missions to the Jupiter system. Furthermore the study will also provide detailed information and tools on how to design the optimum shielding for the instruments, avionics and other radiation sensitive components of the spacecraft.

### 7.2.3 Mechanical deployment of radar antenna

Development of radar antennas for planetary missions is a technology that is currently unavailable in Europe. The *Marsis* antenna of Mars Express was an item delivered by JPL in the US. The development of such an antenna in Europe is seen as important and an ESA Invitation to Tender is in preparation to study, develop and test a radar antenna (including the deployment) of similar size to what has been defined in the JGO model payload. Results of this activity are expected for end 2010 (TBC).

## 7.3 Technology needs and technology plan

Engineering developments are required in several areas to adapt current designs to perform e.g. within the radiation environment or to meet the planetary protection requirements. To support these engineering developments ESA initiates Technology Development Activities (TDA) to bring the required technologies to a TRL of 5 before start of the definition phase. These include topics such as: radiation hard memory, radiation effects on sensors and materials (e.g. resins), characterization of radiation resistant materials, low mass space wire, ...

Several new Technology Development Activities were identified by ESA and are being set up. A shortened list is given here:

- Latch up protection for COTS (Commercial, off-the-shelf) digital components
- Development of a second generation of low mass *SpaceWire* cable
- Radiation effects on sensors and technologies for Cosmic Vision missions
- Assessment and characterization of availability of radiation hard memory
- Study radiation tolerant analogue / mixed signal technology survey and test vehicle design
- Front-end readout ASIC technology study and development test vehicles for front-end readout ASICs
- Survey of critical components for 150 krad power system design including delta radiation characterisation of RH power EEE components
- Radiation characterisation of Laplace critical RH opto-couplers, sensors and detectors to identify suitability for the Laplace mission
- Assessment and characterisation of radiation resistance of materials to the high radiation field of the Laplace mission

## 7.4 Major Open Issues or Trades

- Avoidance of yaw rotation for nadir-looking instruments
- Autonomy and redundancy of critical systems
- Detailed budgets for 2020 (and backup) launch date
- Refinement of instrument definition, in particular resource requirements and accommodation
- Data volume and data rate
- Improvement of radiation model (e.g. shielding effect by Ganymede)

- Radiation margin philosophy
- Definition of instrument thermal budgets and revisit of trade-off for RHU usage
- Investigate further similarities/synergies with Rosetta S/C
- Evaluation of implementation of the requirements dictated by the model payload that will be defined for the industrial study.

## **8 ANNEX**

### **8.1 List of Abbreviations**

AIT	Assembly, Integration & Testing
AIV	Assembly, Integration & Verification
AOCS	Attitude and Orbit Control System
ASIC	Application-specific integrated circuit
BOL	Beginning Of Life
CDF	Concurrent Design Facility
CMOS	Complementary metal-oxide semiconductor
COTS	Commercial, off-the-shelf
CSG	Centre Spatial Guyanais / Guiana Space Centre (Kourou)
DARE	Design against radiation effects
DoF	Degree of Freedom
DSN	Deep Space Network
EEE	Electrical, Electronic and Electro-mechanical
EJSM	Europa Jupiter System Mission
EMC	Electro-magnetic cleanliness
EOL	End of life
ESA	European Space Agency
ESOC	European Science Operations Centre
ESTEC	European Space Research & Technology Centre
FoV	Field of View
GA	Gravity assist
GGA	Ganymede gravity assist
GTO	Geostationary Transfer Orbit
HGA	High gain antenna
ITT	Invitation to Tender
JGO	Jupiter Ganymede Orbiter
JMO	Jupiter Magnetospheric Orbiter
JOI	Jupiter insertion manoeuvre
JPL	Jet Propulsion Laboratory
LEOP	Launch and Early orbit Phase
LGA	Low gain antenna

---

LILT	Low intensity low temperature
MGA	Medium gain antenna
MLI	Multi-layer insulation
NASA	National Aeronautics and Space Administration
OSR	Optical solar reflectors
PCDU	Power Control and Distribution unit
PM	Propulsion model
P/L	Payload
PRM	Perijove raising manoeuvre
RFDU	Radio Frequency Distribution Unit
SA	Solar array
SADM	Solar array drive mechanism
S/C	Spacecraft
SOC	Science Operations Centre
SSMM	Solid state mass memory
TBC	To be confirmed
TBD	To be determined
TBI	To be issued
TBW	To be written
TC/TM	Tele-communications/telemetry
TID	Total ionising dose
TT&C	Tracking, Telemetry, and Command
TRL	Technology Readiness Level
TWTA	Travelling Wave Tube Amplifier
VEEGA	Venus-Earth-Earth Gravity Assist

## 8.2 COSPAR Planetary Protection Policy

The two relevant Planetary Protection Categories are described below. The full Policy can be found in [RD 19].

**Category II** missions comprise all types of missions to those target bodies where there is significant interest relative to the process of chemical evolution and the origin of life, but where there is only a remote chance that contamination carried by a spacecraft could jeopardize future exploration. The requirements are for simple documentation only. Preparation of a short planetary protection plan is required for these flight projects primarily to outline intended or potential impact targets, brief Pre- and Post-launch analyses detailing impact strategies, and a Post-encounter and End-of-Mission Report which will provide the location of impact if such an event occurs. Solar System bodies considered to be classified as Category II are listed in the Appendix to this document [RD 19].

**Category III** missions comprise certain types of missions (mostly flyby and orbiter) to a target body of chemical evolution and/or origin of life interest or for which scientific opinion provides a significant chance of contamination which could jeopardize a future biological experiment. Requirements will consist of documentation (more involved than Category II) and some implementing procedures, including trajectory biasing, the use of clean rooms during spacecraft assembly and testing, and possibly bio burden reduction. Although no impact is intended for Category III missions, an inventory of bulk constituent organics is required if the probability of impact is significant. Category III specifications for selected Solar System bodies are set forth in the Appendix to this document [RD 19]. Solar System bodies considered to be classified as Category III also are listed in the Appendix of [RD 19].

## 8.3 Technology readiness levels

Level	Description
1	Basic principles observed and reported
2	Technology concept and/or application formulated
3	Analytical and experimental critical function and/or characteristic proof-of concept
4	Component and/or breadboard validation in laboratory environment
5	Component and/or breadboard validation in relevant environment
6	System/subsystem model or prototype demonstration in a relevant environment (ground or space)
7	System prototype demonstration in a space environment
8	Actual system completed and "flight qualified" through test and demonstration (ground or space)
9	Actual system "flight proven" through successful mission operations

## 8.4 References

[RD 01]	CosmicVision, BR-247 'Cosmic Vision', 2007, ISBN: 92-9092-489-6
[RD 02]	LAPLACE - A mission to Europa and the Jupiter System for ESA's Cosmic Vision Programme, Proposal leader: Michel Blanc, 2007
[RD 03]	CDF Study report Laplace, CDF-77(A), 2008
[RD 04]	Divine, N. and Garrett, H.B., Charged particle distributions in Jupiter's magnetosphere JGR, V88, 6889-6903, September 1983.GIRE.
[RD 05]	Garrett, H.B., et al., Galileo interim radiation electron model, JPL Publication 03-006 2003.
[RD 06]	Santos-Costa, D., Bourdarie, S., Modeling the inner Jovian electron belt including non equatorial particles Planetary and Space Science, 49, 303-312, 2001
[RD 07]	Sicard, A., Bourdarie, S., Physical electron belts model from Jupiter's surface to the orbit of Europa J. Geophys. Res., 109, 2004.
[RD 08]	Heynderickx, D., Quaghebeur, B., Speelman, E., Daly, E., "Space Environment Information System (SPENVIS): a WWW interface to models of the space environment and its effects", AIAA-2000-0371, 2000. SPENVIS web-site: <a href="http://www.spennis.oma.be/spennis/">http://www.spennis.oma.be/spennis/</a>
[RD 09]	Bourdarie, S., Jupiter environment modeling, technical note.
[RD 10]	Paranicas, C., et al., Europa's near-surface radiation environment, Geophys. Res. Lett., 34, L15103, doi:10.1029/2007GL030834 2007.
[RD 11]	Paranicas, C., and N. André, Radiation environments close to the Jovian satellites, EPSC#3, Muenster, 2008.
[RD 12]	Cooper, J. et al., Energetic ion and electron irradiation of the Galilean satellites, Icarus, 149, 133, 2001.
[RD 13]	LAPLACE Mission Analysis for the 2020 Launch Opportunity, Boutonnet, A., de Pascale, P., Schoenmaekers, J., 2008, ref. number: 532
[RD 14]	Evans, N., et al., Galileo Heavy Ion Model, AGU Fall Meeting, Poster SM23A-0301, San Francisco, 2005.
[RD 15]	Khurana, K.K., et al., The origins of Ganymede's polar caps, Icarus, 191, 193, 2008.
[RD 16]	EJSM/JGO (Laplace) Science Requirements Document, [EJSM/JGO/SCIRD/2008.02], Document providing Science objectives and science requirements, including measurement specifications

---

[RD 17]	EJSM/JGO (Laplace) Payload Definition Document [SCI-PA/2008.029/CE], Document providing preliminary mass and power budgets for the possible science payload configurations
[RD 18]	EJSM/JGO (Laplace) Mission requirements document, SRE-PA/2008.45/ASAW, 2008
[RD 19]	Rummel, J. D., et al. Report of the COSPAR/IAU Workshop on Planetary Protection, COSPAR, Paris, France, 2002
[RD 20]	Technical Note: Report of the Jovian and Saturnian Planetary Protection Working Group (2008), A. Spry, SRE-PA/2008.073
[RD 21]	Outer Planet Mission Analysis Working Group report, technical note, 30.6.2008, Johannes Schoenmaekers
[RD 22]	Margin philosophy for assessment studies (2003), SCI-A/2003.302/AA